

Maintenance & Repair Guide

For *TraFFix MASH Delta[®] Intelligent Crash Cushion TL-2 PLUS*

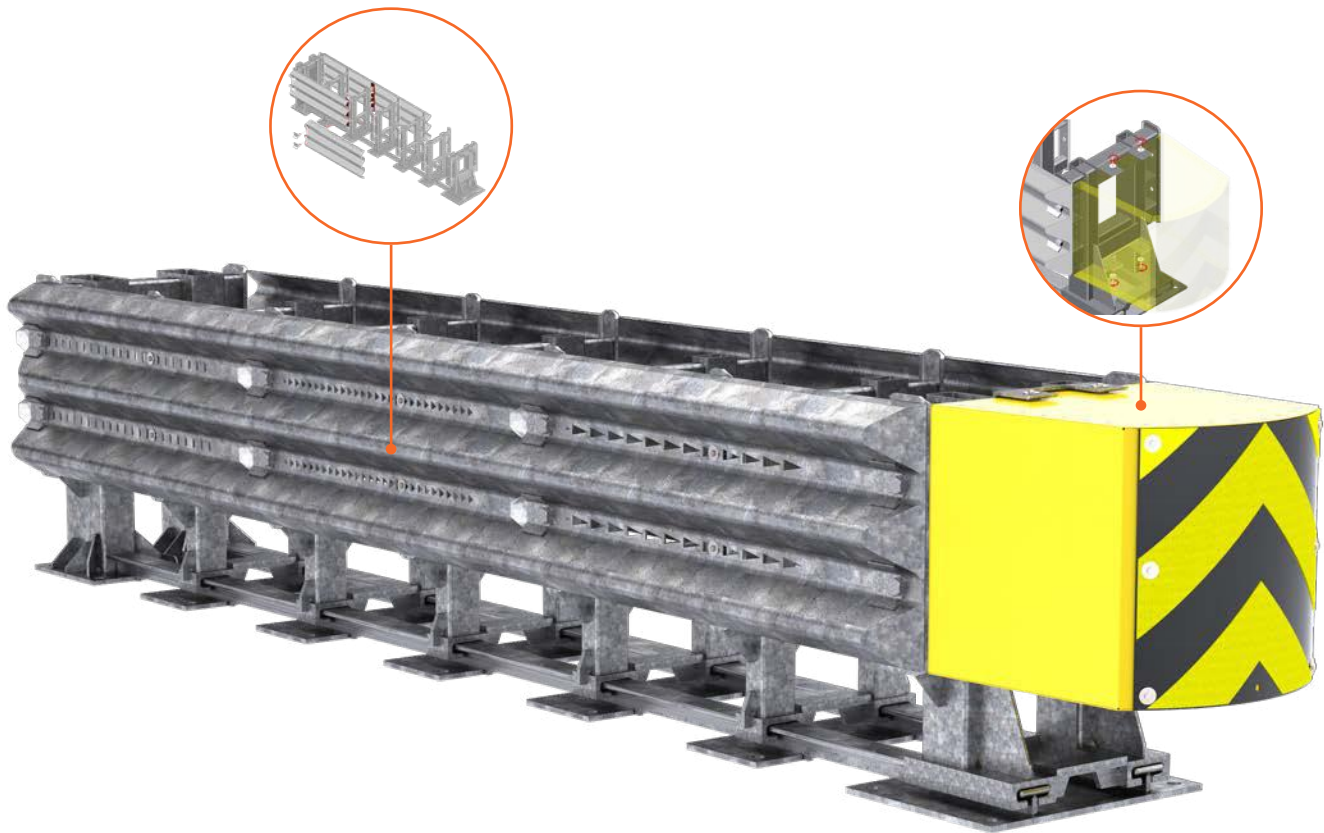

Introduction to Guide



Important: These instructions pertain only to the repair and installation of the Delta® Intelligent Crash Cushion (ICC) TL-2 PLUS. Any deviation from the Delta ICC TL-2 PLUS shown would require consultation with the appropriate highway authority Engineer and or certified Traffix Devices, Inc. representatives. Contact information for Traffix Devices representatives can be found on the last page of this manual.

















Correct Repair of the Delta ICC TL-2 PLUS is essential for proper performance of the system. For this reason, contacting a Traffix Devices, Inc. Engineering Department manager for assistance in repairing the system is recommended. Please read this manual in its entirety before assembling or repairing the Delta ICC TL-2 PLUS. The information in this Manual supersedes all previous versions and manuals, with updated illustrations and other information available at time of printing; however; Traffix Devices, Inc. reserves the right to make changes at any time. For any questions on proper Installation and Operation of the Delta ICC TL-2 PLUS, please contact us at (949) 361-5663 or email info@traffixdevices.com.



Important: This manual applies to the Delta ICC TL-2 PLUS by Traffix Devices, Inc. It pertains only to the model referenced herein. It requires that all installation, service and repair parts be genuine Original Equipment Manufacturer (OEM) Delta ICC TL-2 PLUS parts that have not been modified or repaired from the original factory design.

Safety Symbols

	Attention! Read and Understand.
	Proceed with Caution.
	Hard Hat Protection Required.
	Hearing Protection Required.
	Safety Glasses or Safety Goggles Required.
	Dust Mask Required. Dust Hazard, wear appropriate dust mask in this area.
	Safety Gloves Required.
	Safety Shoes Required.
	Tip Over Hazard. Do not move this equipment without mechanical assistance.
	Pinch point. Keep hands clear during operation.
	Crush Hazard. Keep feet clear.
	Two Person Lift Required.
	Forklift Required. Caution Forklift Operating.
	Warning Overhead Crane. Stay out from under suspended loads.



NOTE: The safety symbols list provided is a general recommendation and should not be considered an all-inclusive list. Always follow best practice.

Table of Contents

Warning and Limitations.....	05
Warranty	06
Dismantling & Recycling, Design Life	08
Overview, Product Description	09
Delta ICC TL-2 PLUS Orientation	10
Tools Required.....	11
Delta Replacement Parts	12
Frontal, Side & Reverse Impact Inspection.....	15
Section 1: Assessing Damaged Parts	
Sentinel.....	19
Track Weldment	20
Diaphragms.....	22
Fender Panels	24
Front Impact Head Diaphragm	26
Front Attenuation Module	27
Delta Hardware	28
Transition	30
Section 2: Removing Damaged Parts	
Side Impact	36
Front Impact.....	40
Section 3: Installing New Parts	
System Rebuild.....	44
Transition Installation	50
Serial Number	56
Inspection Checklist.....	57
TraFFix Devices, Inc. Contact Info	62

Warning and Limitations

TrafFix Devices Inc. (TDI), in compliance with the Manual for Assessing Safety Hardware (MASH) recommended procedures for the Safety Performance of Highway Features. TDI contracts with ISO accredited testing facilities to conduct crash tests, evaluation of tests, and submittal of results to the Federal Highway Administration for Eligibility for Federal-Aid Reimbursement. The Delta® Intelligent Crash Cushion (ICC) TL-2 PLUS was tested to meet the safety evaluation guidelines of MASH. Although tested under TL-2 specifications, the Delta ICC TL-2 PLUS was tested at 50 mph (80 km/hr) impact speed conditions. These tests are intended to evaluate product performance by simulating those impacts outlined by MASH involving a range of vehicles on the roadways, from cars with an approx. weight of 2425 lbs [1100 kg] to trucks with an approx. weight of 5004 lbs [2270 kg]. The Delta ICC is a TL-2 tested device capable of decelerating and stopping the light and heavy weight vehicles 2425 lbs [1100 kg] and 5004 lbs [2270 kg] in accordance with the criteria of Tests 2-30, 2-31, 2-32, 2-33, 2-34, 2-35, 2-36, 2-37 and 2-38 for TL-2 50 mph (80 km/hr). These specified tests are not intended to represent the systems performance when impacted by every vehicle type or every impact condition existing on the roadway. This system is tested only to the test matrix criteria of MASH. TrafFix Devices does not represent nor warrant that the results of these controlled tests show that vehicle impacts with the products in other conditions would necessarily avoid injury to person(s) or property. Impacts that exceed the system's specifications may not result in acceptable crash performance as outlined in MASH; relative to structural adequacy, occupant risk, and vehicle trajectory. TDI expressly disclaims any warrant or liability for injury or damage to person(s) or property resulting from any impact, collision, or harmful contact with products, other vehicles, or nearby hazards or objects by any vehicle, object or person, whether or not the products were installed by third parties. The Crash Cushion system is intended to be assembled, installed and maintained in accordance with specific State and Federal guidelines. TDI offers a directional object marker for the Delta ICC TL-2 PLUS. However, the material is only intended to supplement delineation required by the Department of Transportation's "Manual on Uniform Traffic Control Devices" (MUTCD). The appropriate highway authority approved engineer should be careful to properly select, assemble, and maintain the product. Careful evaluation of the speed, traffic direction, and visibility are some of the elements that require evaluation for the proper selection of a safety appurtenance by the appropriate specifying highway authority.

Warranty

TrafFix Devices warrants to the purchaser that the Delta® Intelligent Crash Cushion (ICC) TL-2 PLUS is free from any defects in materials and workmanship. If this product proves to be defective in material or workmanship during the period of this warranty, TrafFix Devices will repair or replace, at its discretion, the defective product free of charge. The period of this warranty is one-year beginning from the date the purchaser puts the unit into service or one-year from the date of purchase.

To obtain warranty service, the purchaser or distributor must first photograph the unit in question, fill out a warranty authorization form (Pg.7) and email TrafFix Devices to have our Engineering Department evaluate the problem and recommend repair procedures. TrafFix Devices will then issue a signed warranty work approval form to authorize the distributor or customer to repair or replace any items, which TrafFix Devices deems to have been defective. All replacement parts claimed to be defective will be invoiced at the time of shipment, and upon returned and evaluation of defective parts a credit memo will be issued.

This warranty does not extend to any failure of the Delta ICC caused by misuse, abuse, material alteration, non-OEM components, or any negligence in connection with the installation, service, or use of this product. For the correct installation, service, or use of this product refer to the installation manual, repair guide and the inspection checklist.

Warranty Authorization Form

Company Name: _____

Address: _____

Phone: _____ Fax Number: _____

Email: _____

Name of Customer: _____

Date: _____

Serial Number: _____

Replacement and Repair Parts Listed Below? _____

List Part Numbers of Replacement or Repair Items:

— INTELLIGENT CRASH CUSHION —

Describe the Problem and Reason for Failure:

Email this Form along with Pictures to TraFFix Devices
Email: info@traffixdevices.com Phone: (949) 361-5663

Dismantling & Recycling

After the Delta ICC TL-2 PLUS is impacted the damaged parts can be recycled. The front attenuation module is composed of aluminum and can be recycled. In the event of a frontal impact the attenuation module should be removed from the steel impact head and recycled separately from the steel weldments. The Fender Panels, Diaphragms, and Track Weldment are galvanized steel and can be recycled.



Expected Design Life

The Delta ICC TL-2 PLUS is primarily constructed from galvanized steel. The expected life cycle of the Delta ICC is similar to other galvanized steel products on the roadway. The Delta ICC has no modules or plastic that will degrade due to environmental exposure. The system should be inspected periodically to check for rust and damaged parts. If the system is exposed to harsh environmental conditions, such as road salt, it should be inspected more frequently. Damaged parts must be replaced with genuine Original Equipment Manufacturer (OEM) Delta ICC parts that have not been modified or altered from the original factory design.

Overview

The Delta ICC TL-2 PLUS is a Non-Gating Redirective crash cushion manufactured by Traffix Devices, Inc. The Delta ICC has passed all required AASHTO MASH crash tests at a speed of 50 mph (80 km/hr) and can be used in Uni-Directional or Bi-Directional applications. The Delta ICC was designed to be simple and effective in protecting errant vehicles from striking a wide variety of roadside hazards. The fender panels use the standard AASHTO M-180 Thrie beam profile. Utilizing this profile allows the Delta ICC to be easily attached to standard roadside safety hardware. The Delta ICC was Co-Developed with Midwest Roadside Safety Facility (MwRSF) at the University of Nebraska-Lincoln (UNL).

Product Description

The Delta ICC TL-2 PLUS redirects errant vehicles when struck along the side and when impacted at the nose, it attenuates the impacting vehicles kinetic energy. When struck on the nose of the device, the vehicle's kinetic energy is absorbed by the fender panels telescoping rearward and simultaneously shearing/tearing material in the valley's of the Thrie Beam. The cutout patterns in the valleys of the Thrie beam progressively change from the front to the rear to allow the errant vehicle to be safely brought to a controlled stop.



Delta ICC TL-2 PLUS Orientation

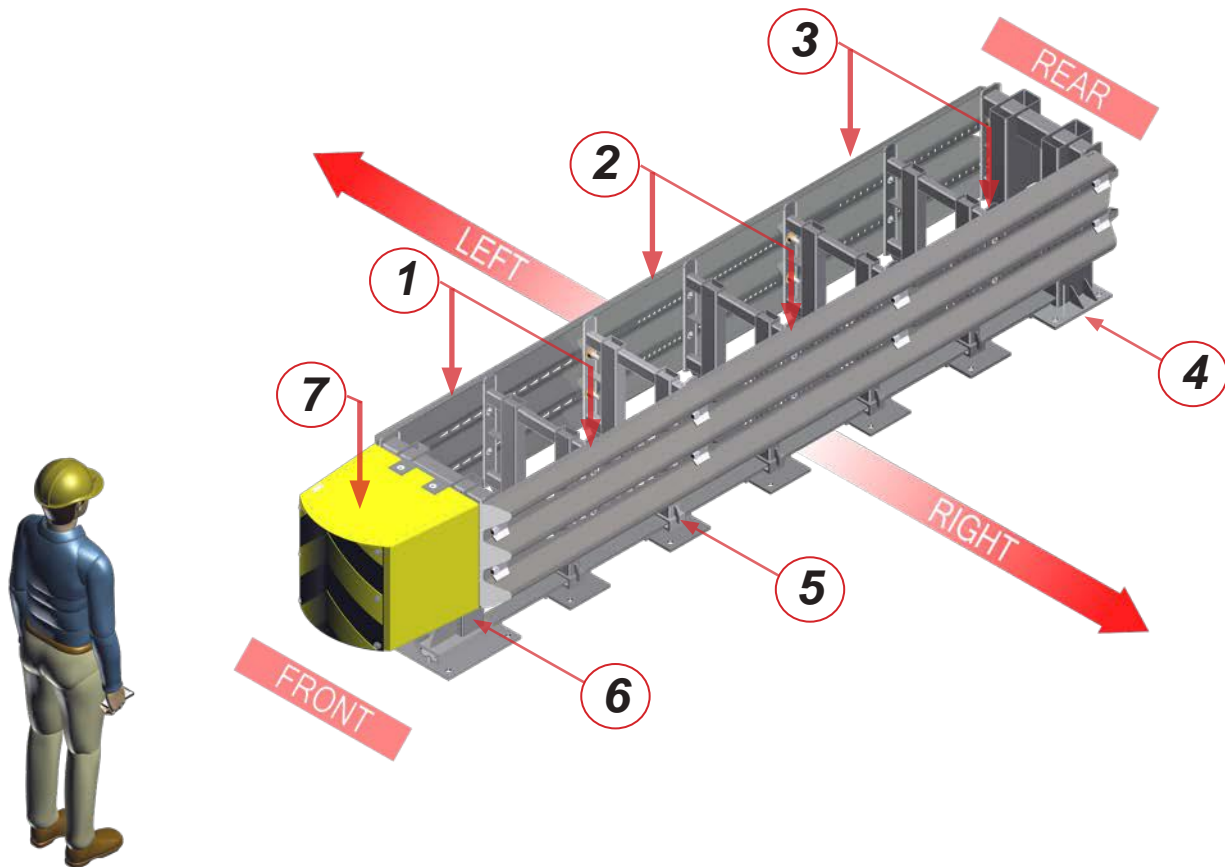

1 - Fender Panel 1N

2 - Fender Panel 3N

3 - Fender Panel 45N

4 - Track

5 - Diaphragm

6 - Front Impact Head Diaphragm

7 - Front Attenuation Module



Tools Required

	<p>Lifting and moving equipment to safely lift 5000 lbs, either a fork lift, tractor or crane. Industrial Lifting Slings to safely lift 5000 lbs.</p>
	<p>3/8" Grade 70 or 80 Welded Chain with Hooks</p>
	<p>Rotary Drill: Bosch RH1255VC or Equivalent 1" Diameter Drill Bit, 12" Long for Rotary Drill Bit for Concrete 20" Long for Rotary Drill Bit for Asphalt</p>
	<p>Socket Wrench 7/16" Socket</p>
	<p>Impact Driver with 7/16" Socket 1-1/8" Socket Torque Wrench with 1-7/16" Socket</p>
	<p>7/16" Wrench 1-1/16" Ratchet Wrench Drill with philips head driver</p>

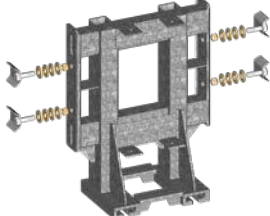
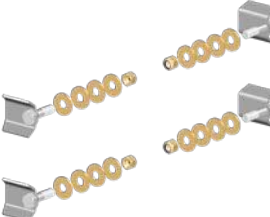
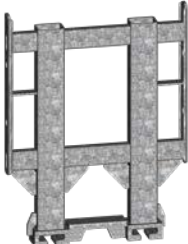
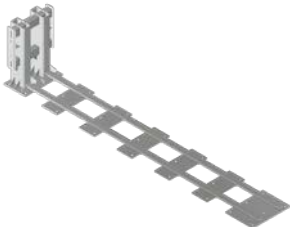

NOTE: The tool list provided is a general recommendation and should not be considered an all-inclusive list.

Delta Replacement Parts

<u>Part No.</u>	<u>Description</u>	
75220-N-Y4	Front Attenuation Module Kit with Hardware, 4 Bolts (1/4"-20 x 1"), 4 Washers (1/4") and Object Marker with Hardware, 6 Bolts (1/4"-20 x 1") and 6 Washers (1/4")	
75230-N-KIT	Front Impact Diaphragm Kit, 1 Front Impact Head Diaphragm, 4 Wing Washers, 4 Nuts (3/4"-10) and 16 Washers (3/4")	
75230-HW-KIT	Front Impact Head Diaphragm Hardware Kit, 4 Wing Washers, 4 Nuts (3/4"-10) and 16 Washers (3/4")	
75240-N	Steel Diaphragm (5 per system)	
75250-TL2-N	Track Weldment	
75208-CA2-KIT	Concrete Anchor Rod Assembly, 27 Anchor Rod (7/8"-9 x 8"), 27 Nut (7/8"-9) and 27 Washers (7/8")	
75218-AA2-KIT	Asphalt Anchor Rod Assembly, 27 Anchor Rod (7/8"-9 x 18"), 27 Nut (7/8"-9) and 27 Washers (7/8")	

Part No.

Description

75260-TL3-1N-KIT

Fender Panel 1N, Kit with Hardware,
2 Wing Washers, 2 Lock Nuts (3/4"-10), 2 Washers (3/4"),
2 Sacrificial Bolts (1/4"-20 x 1-1/2"), 2 Lock Nuts (1/4"-20) and
4 Washers (1/4") (2 per system)

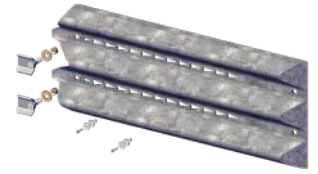

75260-TL3-3N-KIT

Fender Panel 3N, Kit with Hardware,
2 Wing Washers, 2 Lock Nuts (3/4"-10), 2 Washers (3/4"),
2 Sacrificial Bolts (1/4"-20 x 1-1/2"), 2 Lock Nuts (1/4"-20) and
4 Washers (1/4") (2 per system)

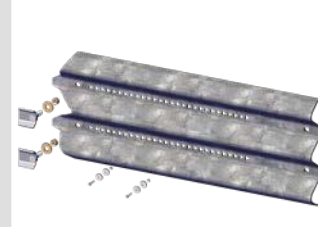

75260-TL3-45N-KIT

Fender Panel 45N, Kit with Hardware,
2 Wing Washers, 2 Lock Nuts (3/4"-10), 2 Washers (3/4"),
2 Sacrificial Bolts (1/4"-20 x 1-1/2"), 2 Lock Nuts (1/4"-20) and
4 Washers (1/4") (2 per system)

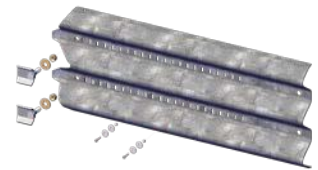

75240-HW-KIT

Floating Diaphragm Hardware Kit,
4 Bolts (1/4"-20 x 1-1/2"),
4 Nuts (1/4"-20) and 8 Washers (1/4") (3 kits per system)



75250-HW-KIT

Rear Track Backup Weldment Hardware Kit,
4 Wing Washers, 4 Nuts (3/4"-10) and 16 Washers (3/4")

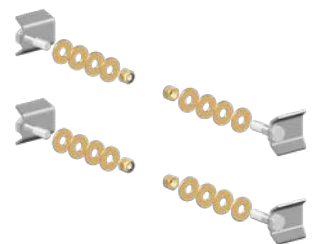

75270-SBST

Standard Bridge Shoe Transition Panel

! *User(s) has the responsibility to determine a suitable transition that must be compliant with local and state government standards.*



75270-BST-02-KIT

TDI Bridge Shoe Transition Kit with Hardware,
1 Bi-Directional Transition Panel and 5 Anchor Bolts (3/4")

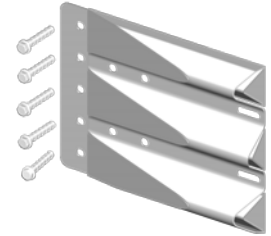

75270-BST-02

TDI Bridge Shoe Transition Panel



75270-RH-KIT

Right Transition Weldment Kit with Hardware,
3 Anchor Bolts (3/4"), 5 Blockout Holders,
10 Wooden Lag Bolts (3/8"), 10 Self-Tapping Screw (3/8"),
2 J-Bolt (8") and 2 Nylock Nuts (1/2"-13)

! *Wood Blocks NOT Included. Barrier NOT Included.*

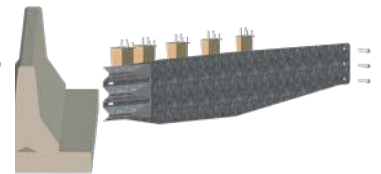

75270-RH

Right Transition Weldment



75270-LH-KIT

Left Transition Weldment Kit with Hardware,
3 Anchor Bolts (3/4"), 5 Blockout Holders,
10 Wooden Lag Bolts (3/8"), 10 Self-Tapping Screw (3/8"),
2 J-Bolt (8") and 2 Nylock Nuts (1/2"-13)

! *Wood Blocks NOT Included. Barrier NOT Included.*

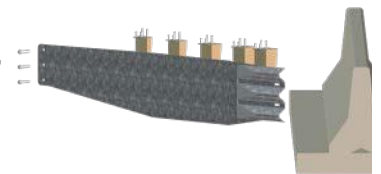

75270-LH

Left Transition Weldment



75270-HW-KIT

Transition Hardware,
3 Anchor Bolts (3/4"), 5 Blockout Holders,
10 Wooden Lag Bolts (3/8"), 10 Self-Tapping Screw (3/8"),
2 J-Bolt (8") and 2 Nylock Nuts (1/2"-13)

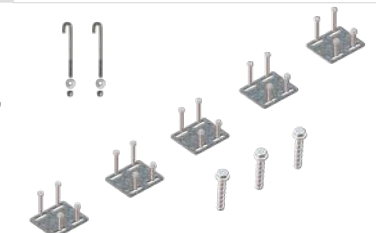

Frontal Compression Inspection:



Step 1 :

Inspect Track



Step 2 :

Inspect Diaphragms



Step 3 :

Inspect Fender Panels



Step 4 :

Inspect Hardware
Wing Washers, Anchor Bolts
and Sacrificial Bolts



Side Impact Inspection:



Step 1 :

Inspect Track



Step 2 :

Inspect Fender Panels



Step 3 :

Inspect Diaphragms



Step 4 :

Inspect Front Attenuation Module and Object Marker



Step 5 :

Inspect Hardware
Wing Washers, Anchor Bolts
and Sacrificial Bolts



Reverse Side Impact Inspection:



Step 1 :

Inspect Track



Step 2 :

Inspect Transition



Step 3 :

Inspect Fender Panels



Step 4 :

Inspect Diaphragms



Step 5 :

Inspect Hardware
Wing Washers, Anchor Bolts,
Sacrificial Bolts and Wood
Blocks



NOTE: Wood Blocks NOT Included.

Section 1: Assessing Damaged Parts



Sentinel must be in the following condition:

The Sentinel must not be broken, cracked or cut. Internal components must not be exposed. The enclosure cover must be sealed tight with all four (4) screws intact. Sentinel must be firmly secured to the Delta backup structure.

Track Weldment

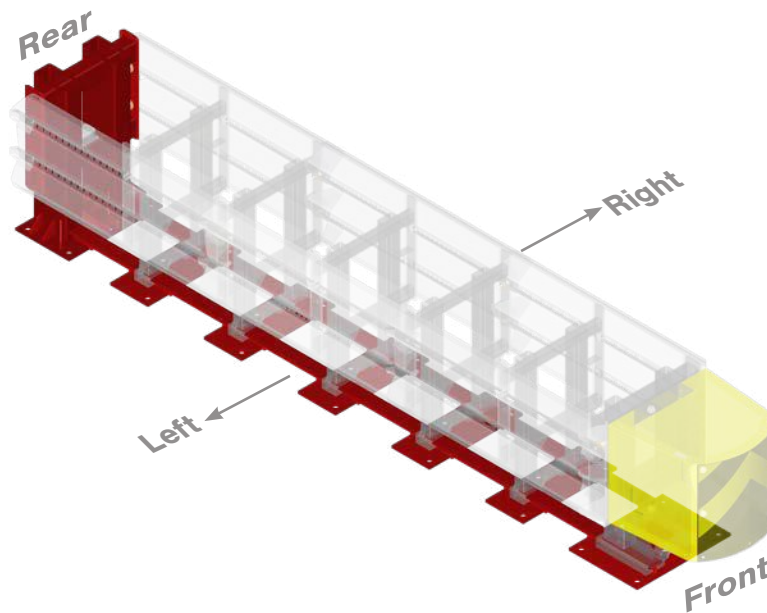

Track must be in the following condition:

Inspection of the Delta Track is key in determining the next steps in a repair. The Delta track is designed to withstand a level 2 test impact at 50 mph (80 km/hr), an impact outside of these conditions could result in damage to the track. Any damage that violates the criteria in the following pages will require replacement of the Track.

Rail Slides: The width of the rail slides should be 15" \pm 3/8" (381 mm). The diaphragms must slide freely down the track without binding.

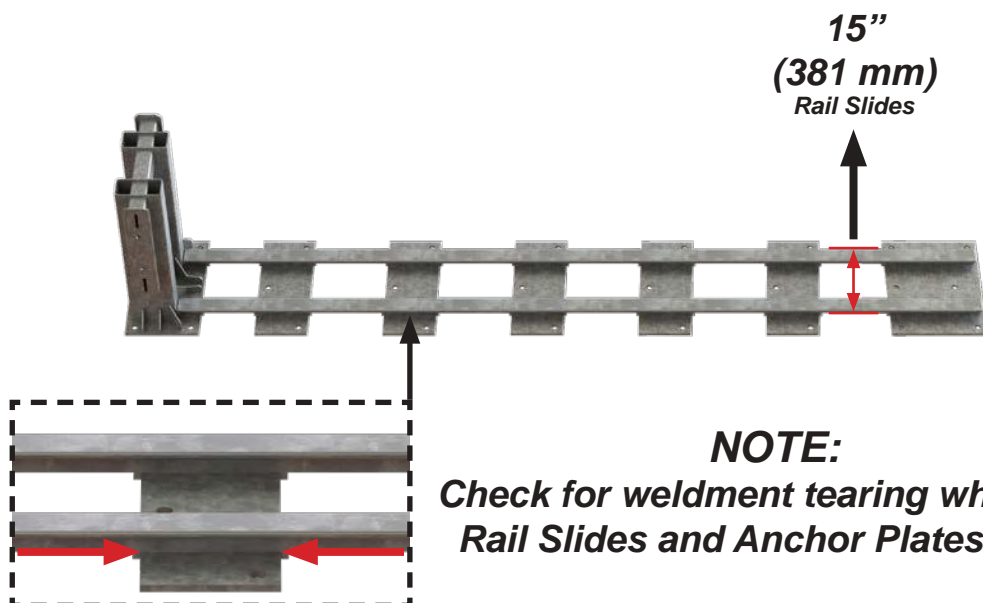

NOTE:
Check for weldment tearing where the Rail Slides and Anchor Plates meet.

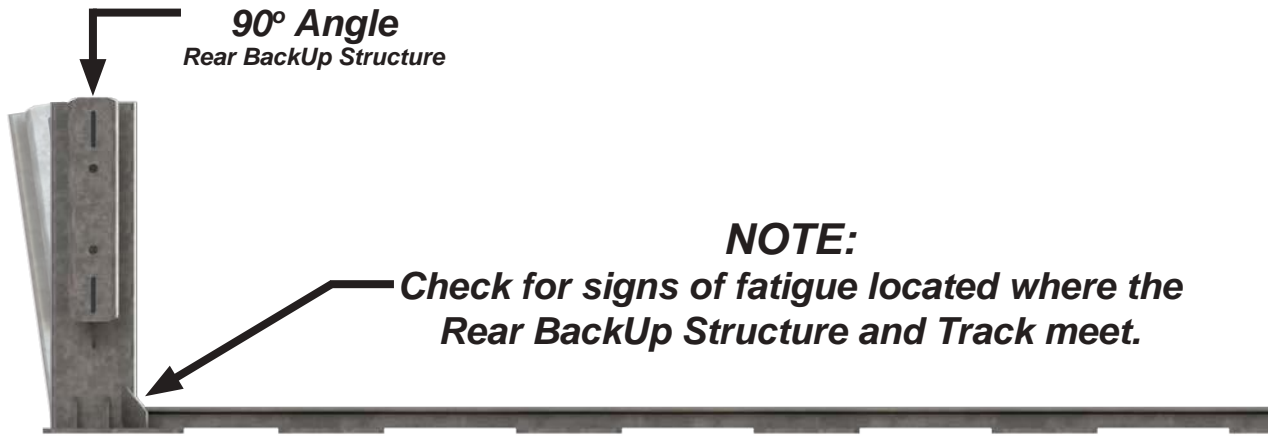

BackUp Structure Angle: The BackUp Structure must have a 90° vertical angle with an allowable 1" (25 mm) out of plumb. If the BackUp Structure exceeds 1" (25 mm), Track replacement is required.

Vertical Tubes: The vertical tubes must not be torn and have a length of 8" (203 mm) with total allowable deformation depth of .50" (13 mm). Total deformation depth that exceeds .50" (13 mm) or if tearing is present on the vertical tubes, replacement of the Track is necessary.

Side Plates: Measurements for side plates must be taken from the inner vertical tube (facing the side plates) to the outer side plate, as shown below. The total allowable deformation of the side plate is .25" (6 mm).

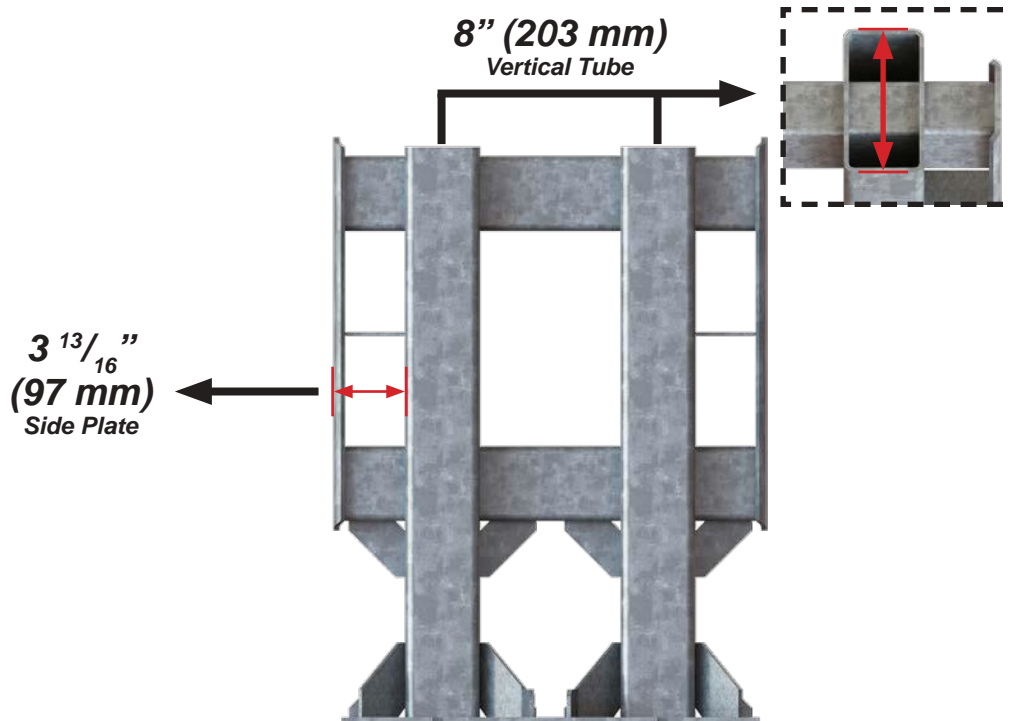

Diaphragms

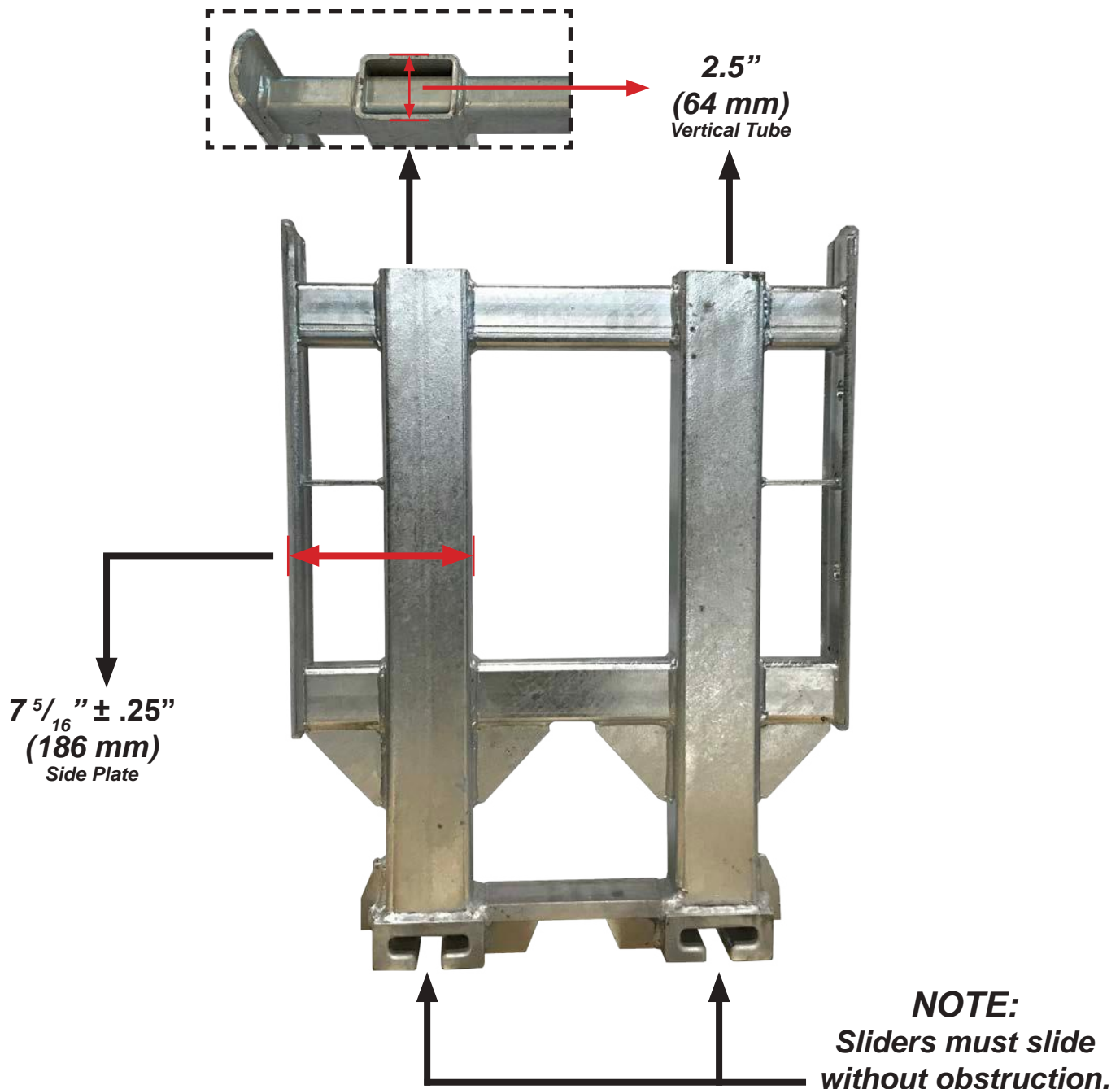

Diaphragms must be in the following condition:

The vertical tubes must not be torn and have a length of 2.5" (64 mm) with total allowable deformation depth of .25" (6 mm). Side plates must be 7 5/16" ± .25" (186mm) and measured as above to determine if reusable after an impact. Sliders must have the capability of sliding onto the track with no obstruction or binding.

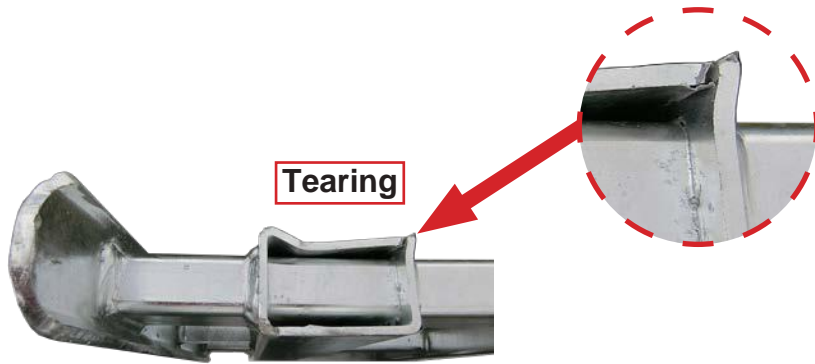

Damaged Diaphragm(s) that require replacement:

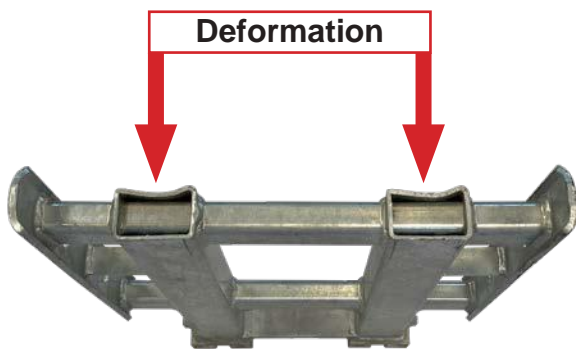

The Delta ICC TL-2 PLUS system has five (5) galvanized steel diaphragms located between the Front Impact Head Diaphragm and the Back Up Structure. An impact that exceeds level 2 test criteria 50 mph (80 km/hr) could cause potential damage to the vertical tubes or side plates.

When inspecting vertical tubes, key things to look for are deformation and tearing. Total deformation depth that exceeds .25" (6 mm) shall require replacement. If any tearing is present on the vertical tubes, replacement of the diaphragm(s) is necessary.

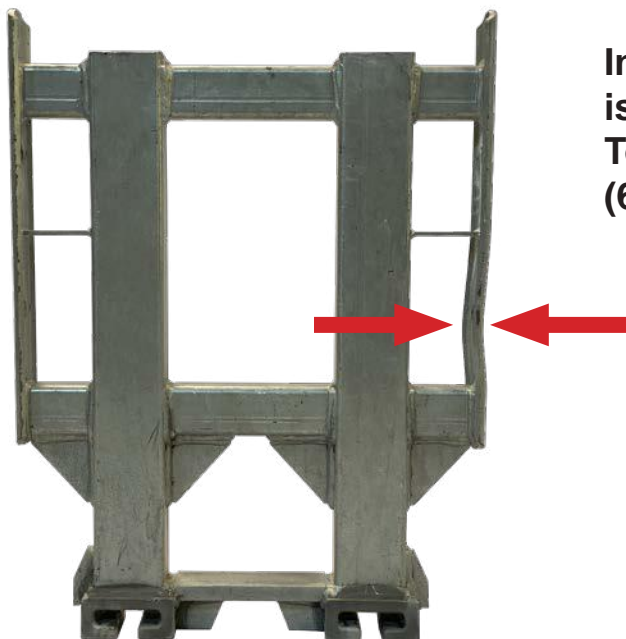

Inspecting the side plates of the diaphragms is crucial to the performance of the system. Total deformation depth that exceeds .25" (6 mm), shall require replacement.

Fender Panels

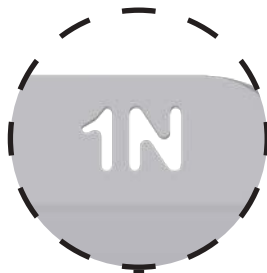

NOTE:
The Fender Panels identification number is located on the trailing edge corner of each panel.

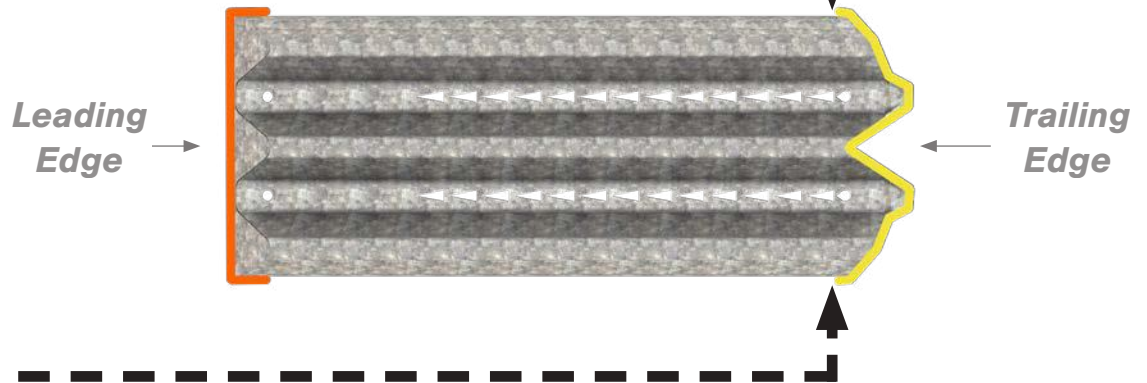

Fender Panels must be in the following condition:

The pattern cutouts must all be undamaged, without tears or bulging. The trailing edge must not be bent or damaged. The panels must have a length of $44.5'' \pm .25''$ (1130 mm) measured from the center of the leading to trailing edge mounting location (as below).

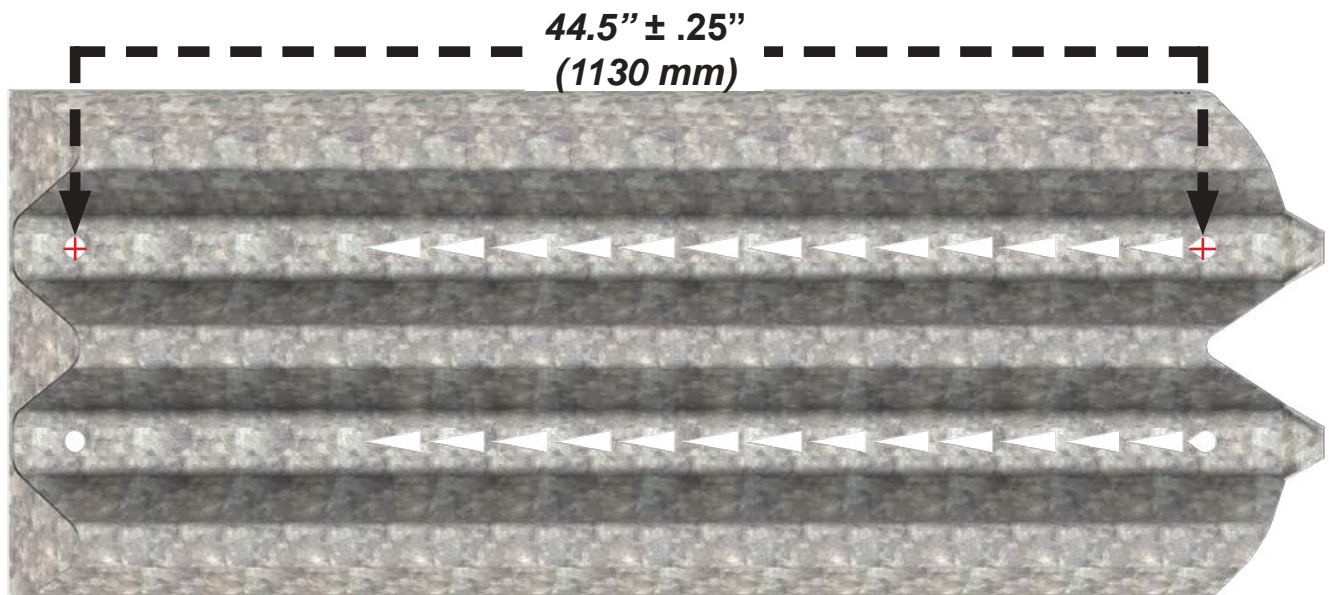



Reverse Side Impact

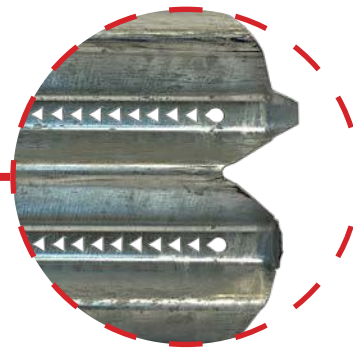

Damaged Fender Panels that require replacement:



Side Impact

When inspecting fender panels, it is important to look for any deformation that would prevent proper telescoping, lapping or attenuation of the system. If deformation causes a gap at the lapping joint greater than .875" (22 mm) the fender panel should be replaced. The trailing edge ramps should also be in acceptable condition to ensure proper performance of the system. The panels should measure 44.5" (1130 mm) from the center of the leading edge mounting holes to the center of the trailing edge mounting holes.



Frontal Impact

Inspecting the panels cutout pattern is crucial. Look for partially torn, fully torn and any bulging of the pattern cutout located in the wing washer area. If any tearing or bulging of the pattern cutouts is visible, fender panel(s) replacement is required.



Frontal Impact

Front Impact Head Diaphragm

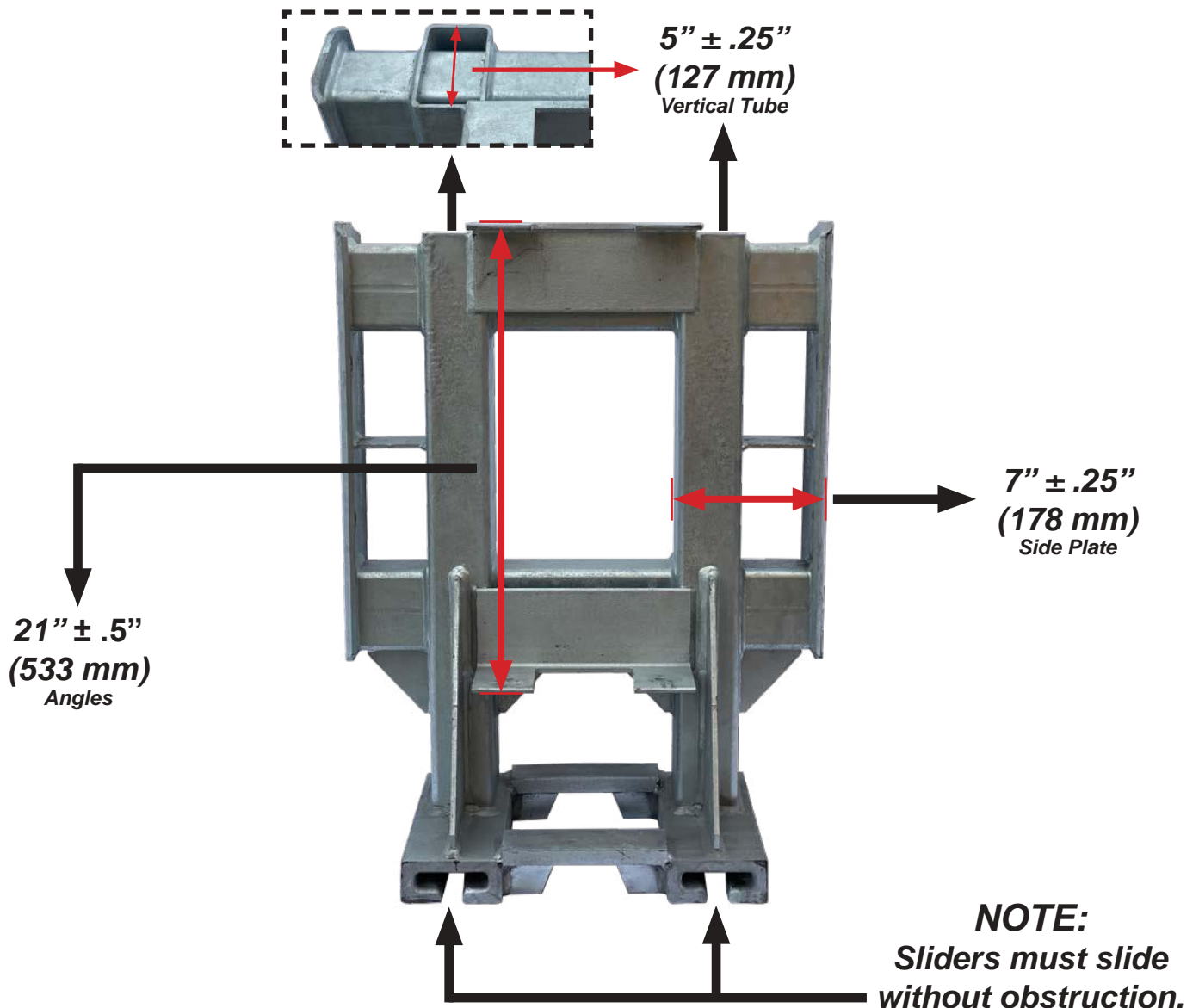

Front Impact Diaphragm must be in the following condition:

The vertical tubes must not show tearing and have a length of 5" (127 mm) with total allowable deformation depth of .25" (6 mm). Side plates must be 7" ± .25" (178mm) and measured as above to determine if reusable after an impact. The top and bottom angles used to mount the attenuation module should be spaced 21" (533 mm) apart with an allowable deformation limit of ± .5". Sliders must have the capability of sliding onto the track with no obstruction or binding.

Front Attenuation Module

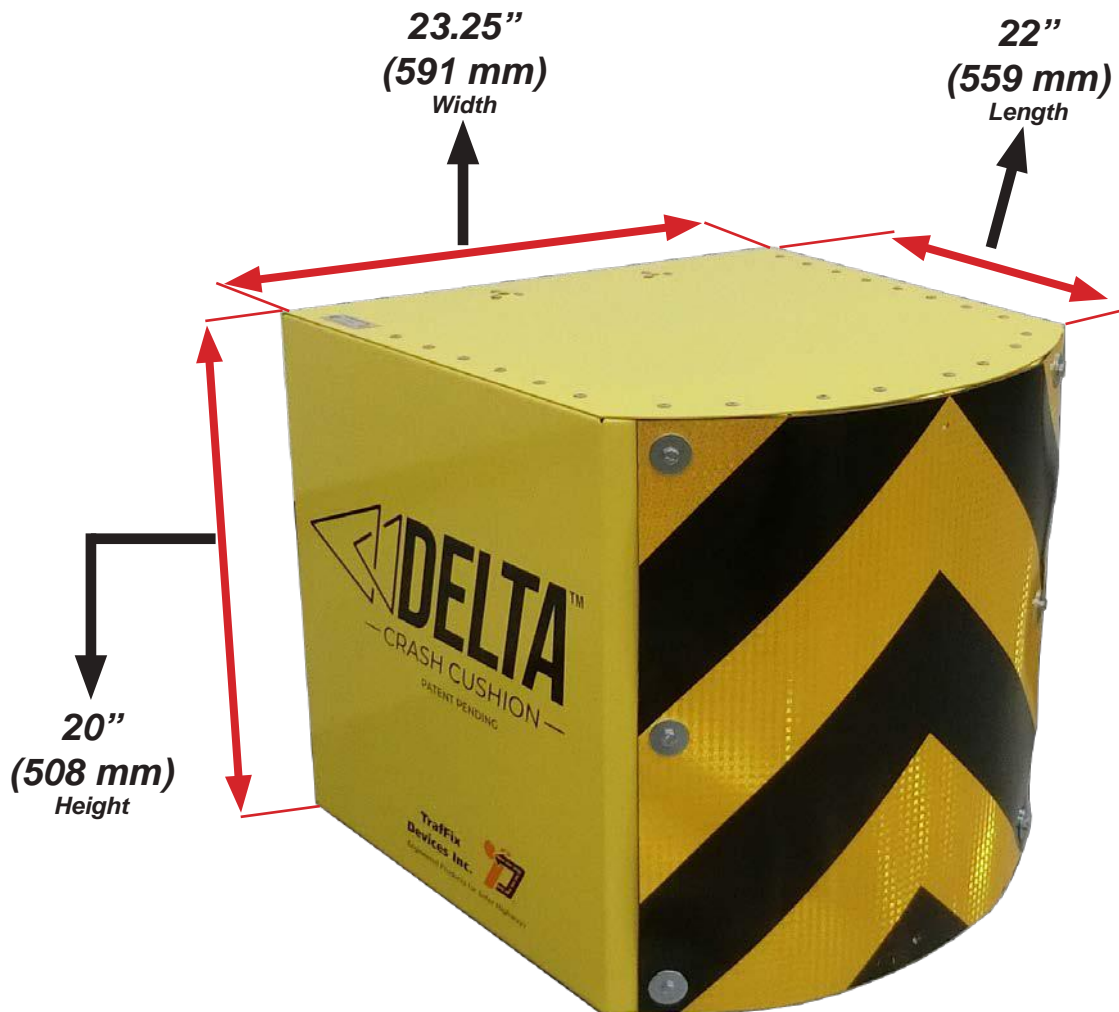

Front Attenuation Module must be in the following condition:
The front attenuation module must not be torn. Honeycomb located inside the front attenuation module must not be exposed. The curved section can be dented, as long as delineation panel (object marker) can be mounted.

Wing Washers

The Delta ICC TL-2 PLUS contains 16 wing washers. The wing washer hardware consists of (1) wing washer, (1) washer *Front Impact Head and BackUp Structure Require (4) washers and (1) nut. Wing washers must not be loose, worn, rusted or damaged. If wing washers have become loose, tighten to have 4 threads visible or approximately .5" (13 mm). Any damaged wing washers must be replaced.

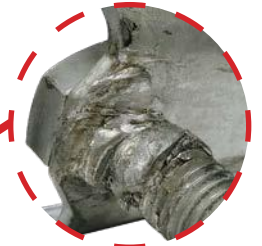
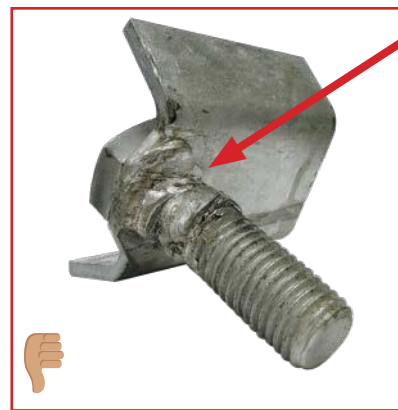
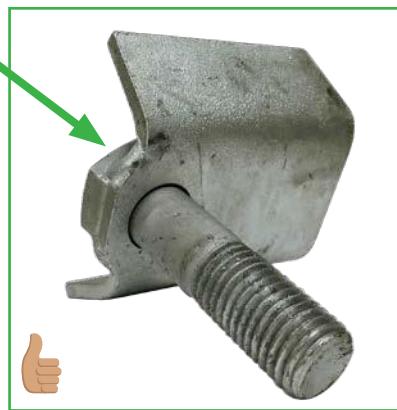
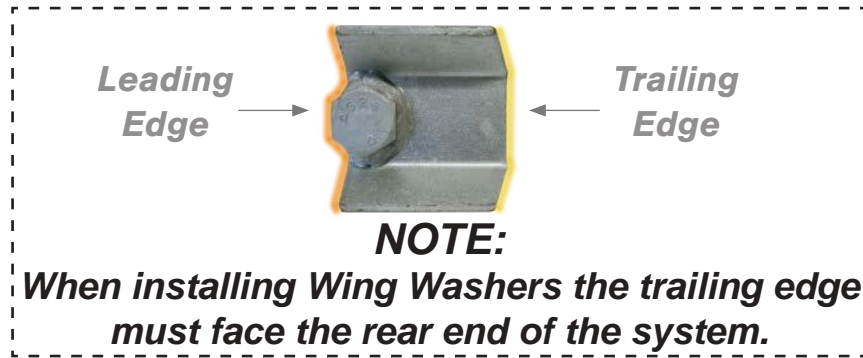

Anchor Bolts

The Delta system consists of 27 anchor bolts. Each anchor bolt assembly consists of (1) bolt, (1) washer and (1) nut. Anchor bolt(s) must hold the proper torque. They must not be bent, cracked or rusted. If any of these conditions apply, the anchor bolt must be replaced.

Asphalt
10 ft-lbs (14 Nm)



Concrete
100 ft-lbs (135 Nm)

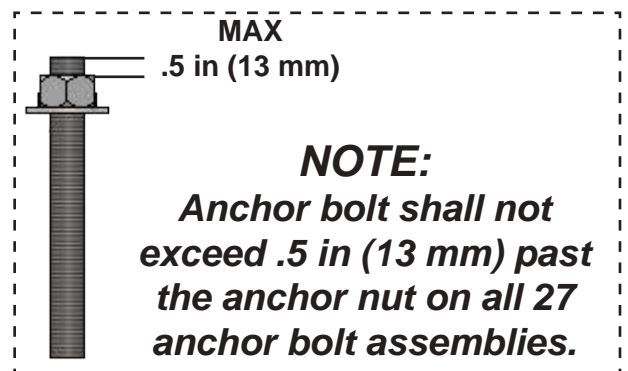

Sacrificial Hardware

The Delta system consists of 12 sacrificial bolts. The sacrificial bolts secure the floating diaphragms in place. Inspect the system for any loose, missing or damaged bolts. The sacrificial hardware assembly consists of (1) bolt, (2) washers, and (1) nut. If bolts have become loose, tighten bolts so that the diaphragm is centered between the fender panels and the washers do not rotate freely. For missing or damaged bolts, replacement is necessary. For correct placement of the sacrificial bolts, space floating diaphragms 22.25" (565 mm) on centers or refer to the fender panel pattern cutout (shown below). *Detailed illustration Pg.48.*

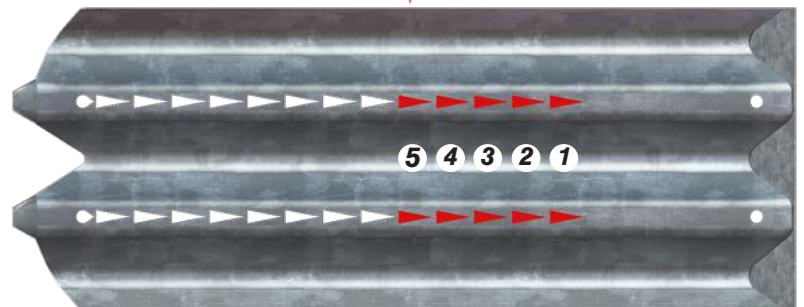
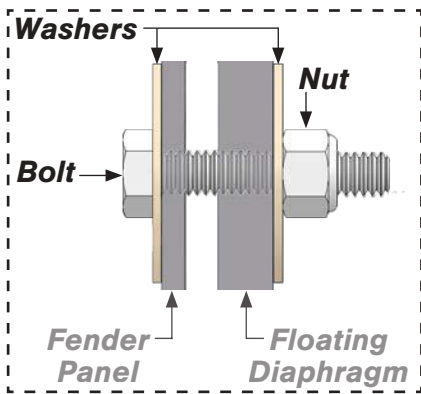
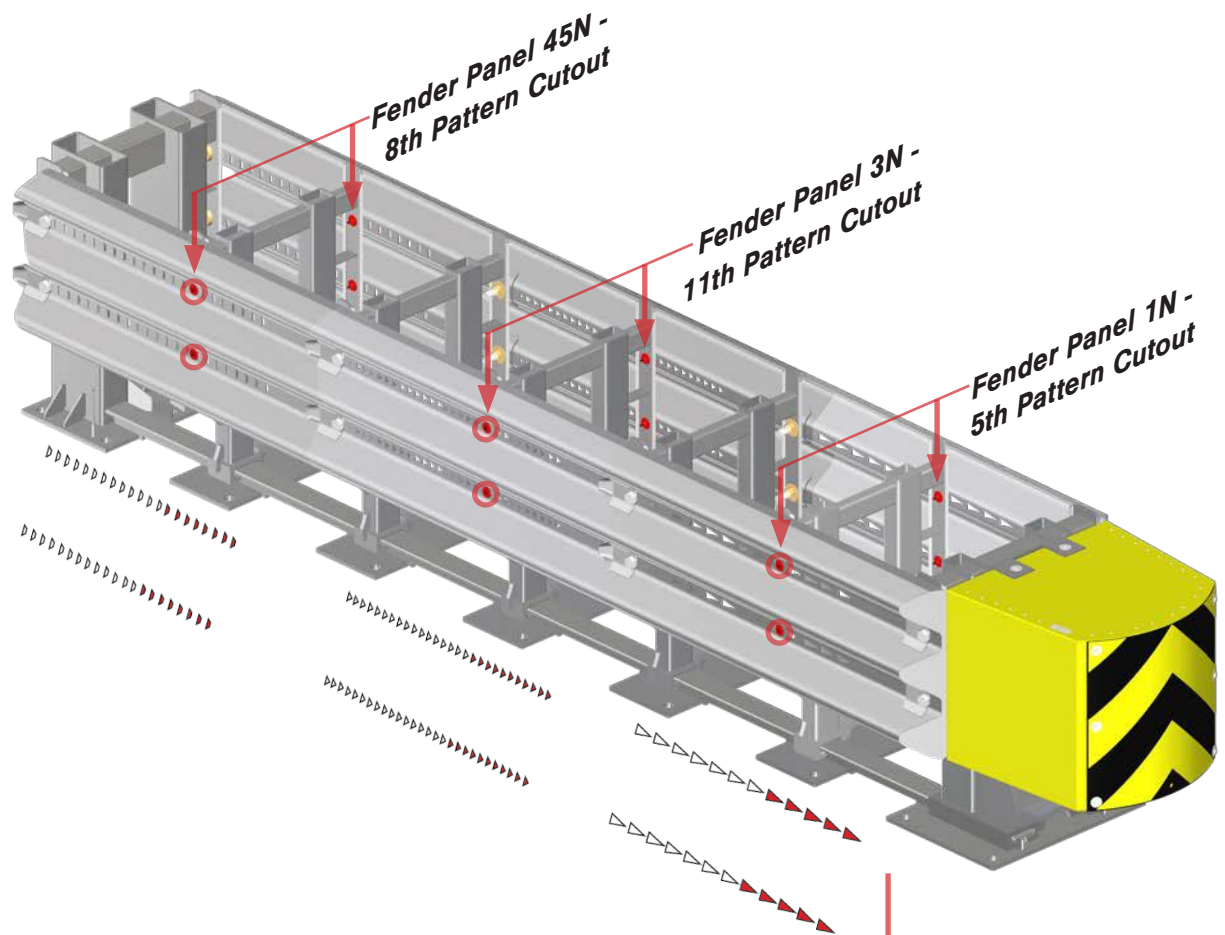

TDI Transition Panel

NOTE:

Check for any fatigue on Weldment.



Transition Panel must be in the following condition:

The Thrie beam (leading edge) shall not be torn or show deformation that would prevent proper telescoping of the fender panels. There shall be no deformation that would create a gap between the fender panel (45N) and transition panel that exceeds .625" (16 mm). The weldment must not show fatigue at welded areas. Anchor bolts must be tightened so the trailing edge of the transition panel is flush with the barrier.

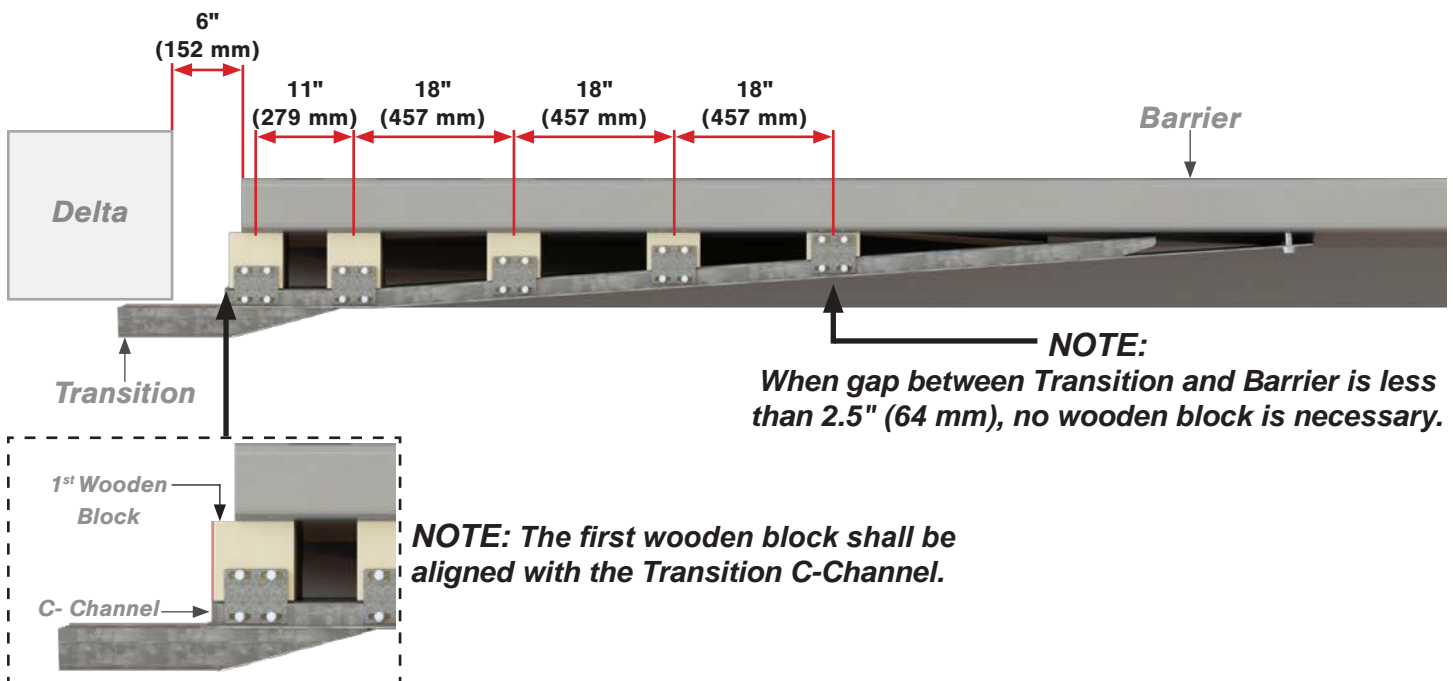

Transition Hardware

3/4" Hilti Anchor Bolt



The trailing edge of the Delta Transition requires three (3) anchor bolts. The anchor bolts secure the transition to barrier. Anchor bolts must be tightened so the trailing edge of the transition is flush with the barrier.

Blockout Holder



The Delta Transition requires each wooden block to have a blockout holder. The blockout holder prevents the wood blocks from shifting.

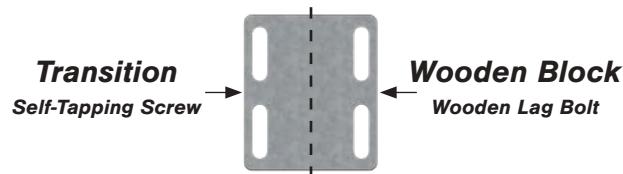

3/8" Self-Tapping Screw



The self-tapping steel screws are drilled into the C-Channel of the transition. Each blockout holder requires two (2) self-tapping screws. For correct placement of self-tapping screws refer to the image below.

3/8" Wooden Lag Bolt



The wooden lag bolts are drilled into the wooden block(s). Each blockout holder requires two (2) wooden lag bolts. For correct placement of wooden lag bolts refer to the image below.

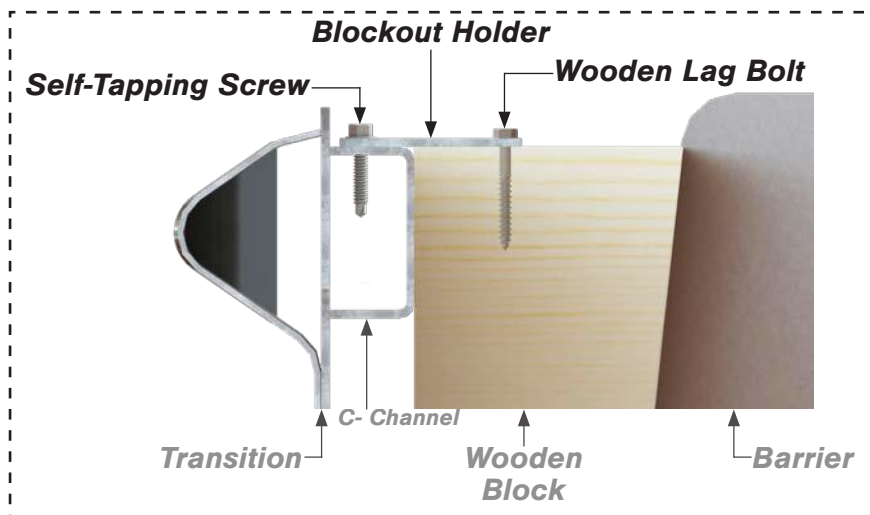

TDI Bridge Shoe Transition

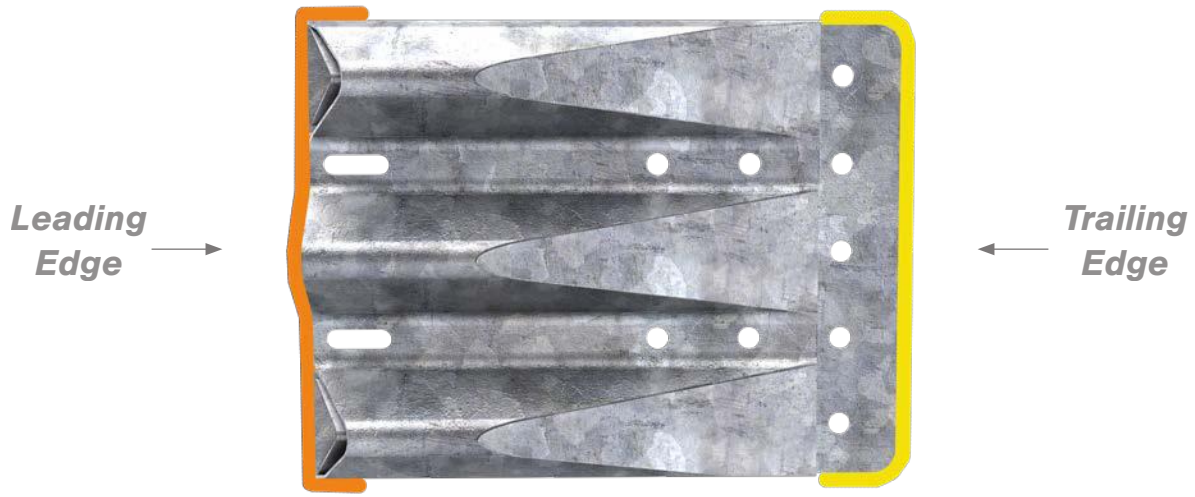

TDI Bridge Shoe Transition must be in the following condition:
The leading edge shall not be torn or show deformation that would prevent proper telescoping of the fender panels. There shall be no deformation that would create a gap between fender panel (45N) and the bridge shoe transition that exceeds .625" (16 mm). The bridge shoe transition peaks have an allowable deformation limit of 0.5" (13 mm). The weldment must not show fatigue at welded areas. Anchor bolts must be tightened so the trailing edge of the transition panel is flush with the barrier.

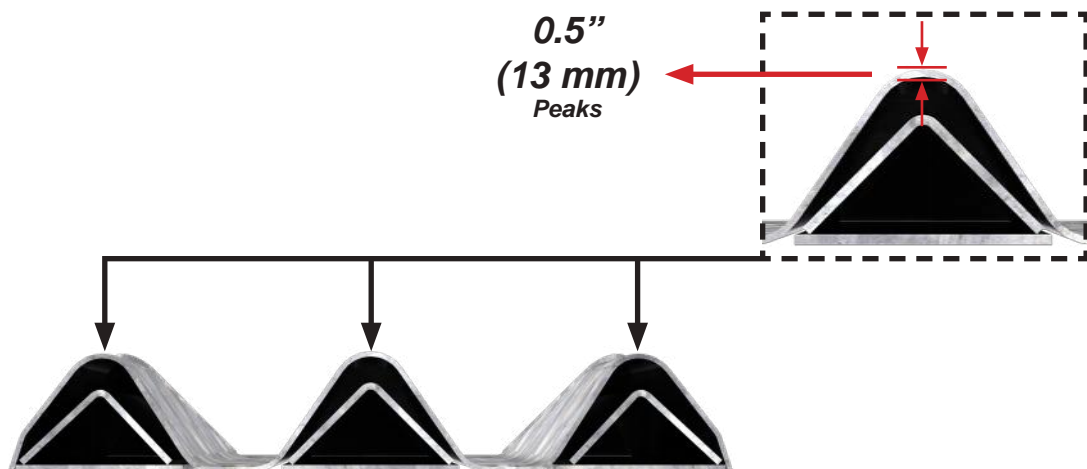

Transition Hardware

3/4" Hilti Anchor Bolt



The trailing edge of the Delta Transition requires five (5) anchor bolts. The anchor bolts secure the transition to barrier. Anchor bolts must be tightened so the trailing edge of the transition is flush with the barrier.

This Page Intentionally Left Blank

Section 2: Removing Damaged Parts



Side Impact

Removing damaged Fender Panels from a side impact.



Step 1

Identify the damaged fender panels. Starting with the forward-most damaged fender panel loosen and remove the leading and trailing edge wing washer hardware and remove fender panel.

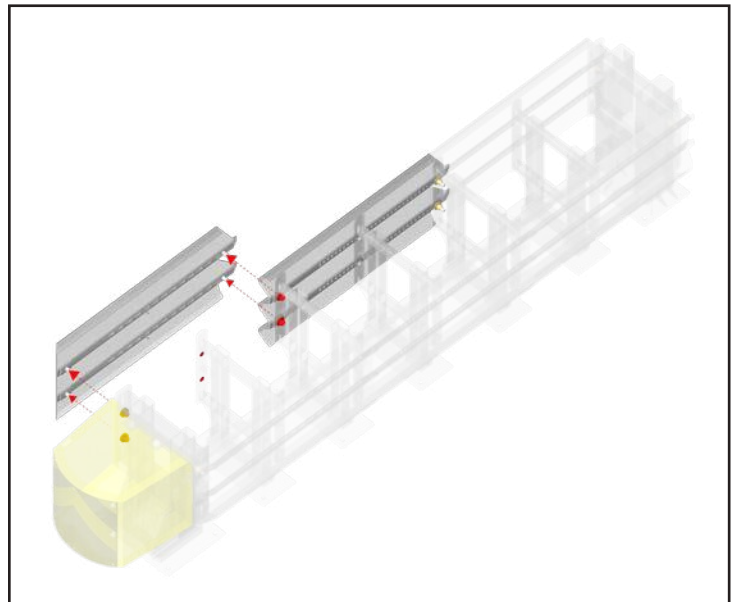

Step 2

Moving rearward on the system begin loosening the next damaged fender panel. This panel will only be supported by the trailing edge wing washers so the leading edge must be supported. Remove the wing washer hardware and remove fender panel.

NOTE: Repeat steps 1-2 for any remaining damaged panels.

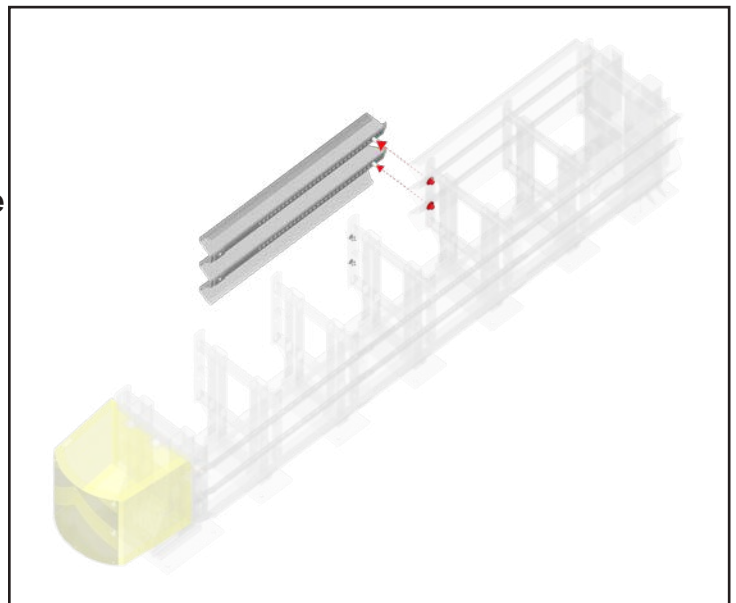

Inspection

When removing damaged fender panels ***always*** inspect diaphragms for any damage.

If the diaphragms are ***not*** damaged, move onto Section 3 for Installation of New Parts.

! **NOTE:** If any diaphragms have damage outside of the acceptable range, proceed to Step 3.

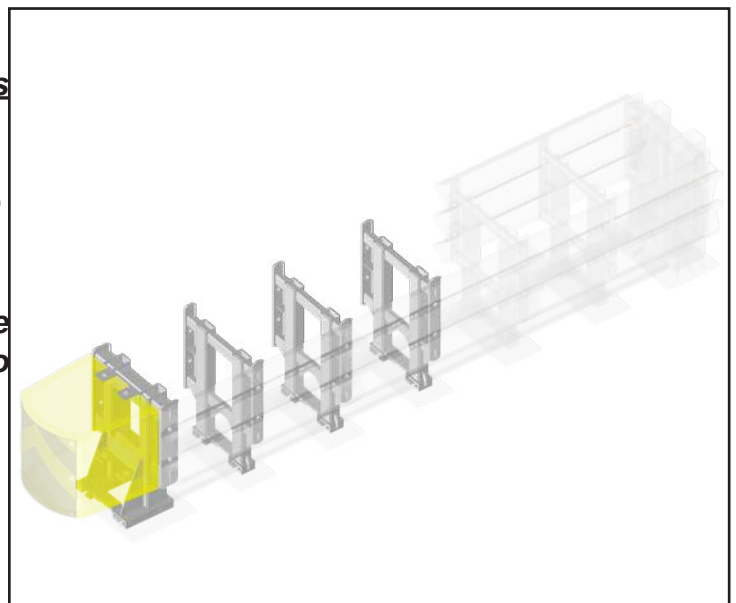

Step 3

Loosen the bolts securing the Front Attenuation Module to the Front Impact Head Diaphragm. Start by removing the bottom two (2) bolts and then remove the top two (2) bolts. Lift the Front Attenuation Module out of position.

NOTE: Place and keep Front Attenuation Module and hardware in safe area.

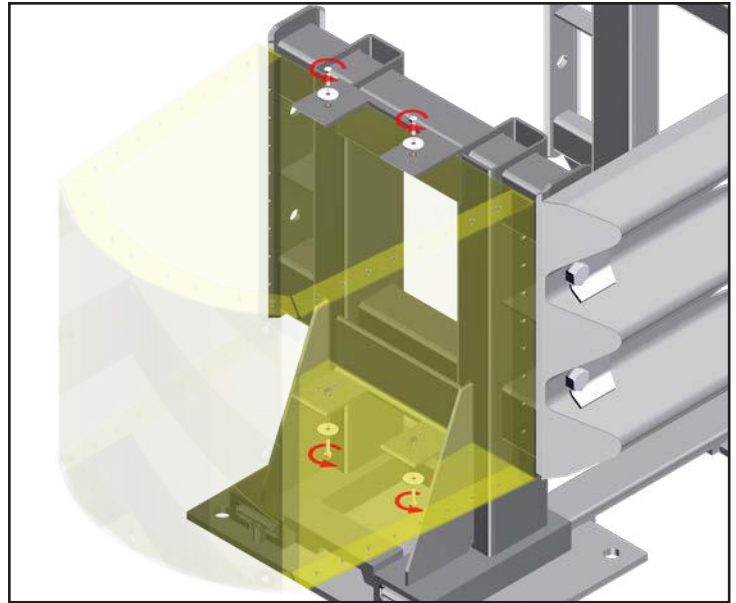

Step 4

In order to remove damaged diaphragm(s), the fender panels on the non-impacted side must be removed. Repeat steps 1-2 for the panels on the opposite side (the undamaged panels). Remove panels far back enough to reach damaged diaphragm(s).

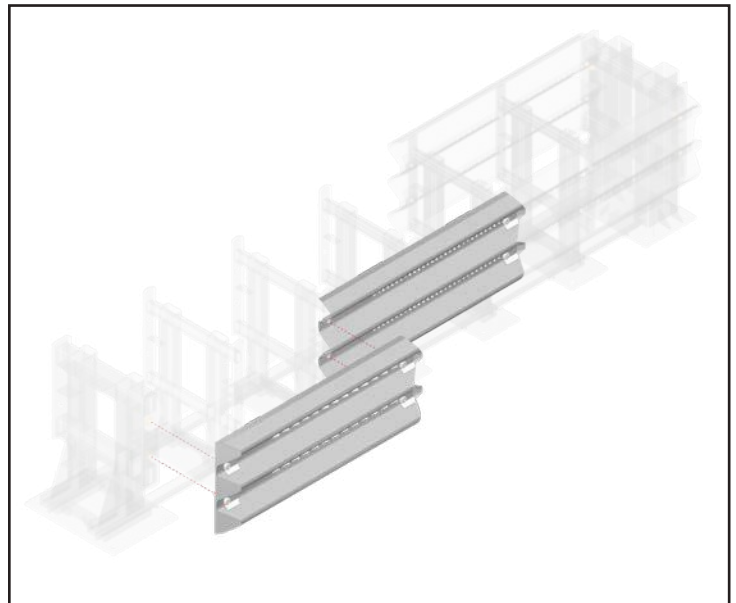

Step 5

Slide and remove the Front Impact Head Diaphragm off the track.

NOTE: Place and keep Front Impact Head Diaphragm in safe area.

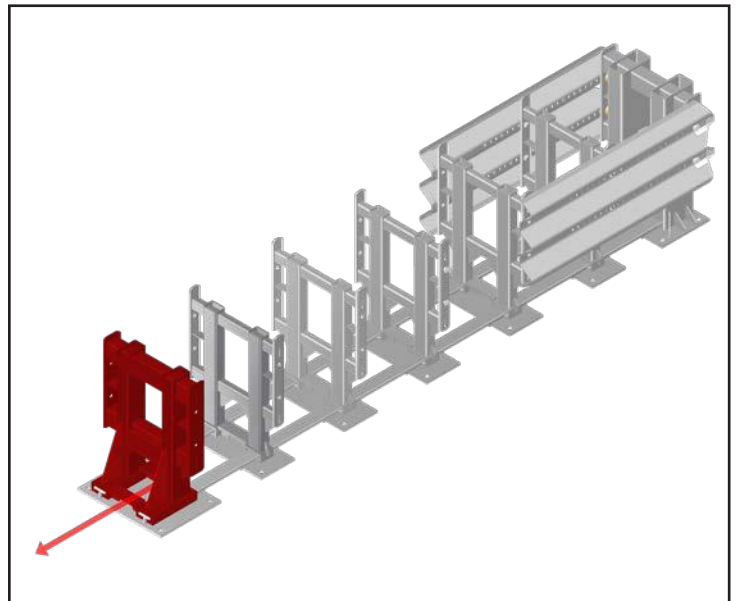

Step 6

Slide and remove the diaphragm(s) off the track until damaged diaphragm(s) have been reached and removed.

NOTE: Place and keep Diaphragm(s) in safe area.

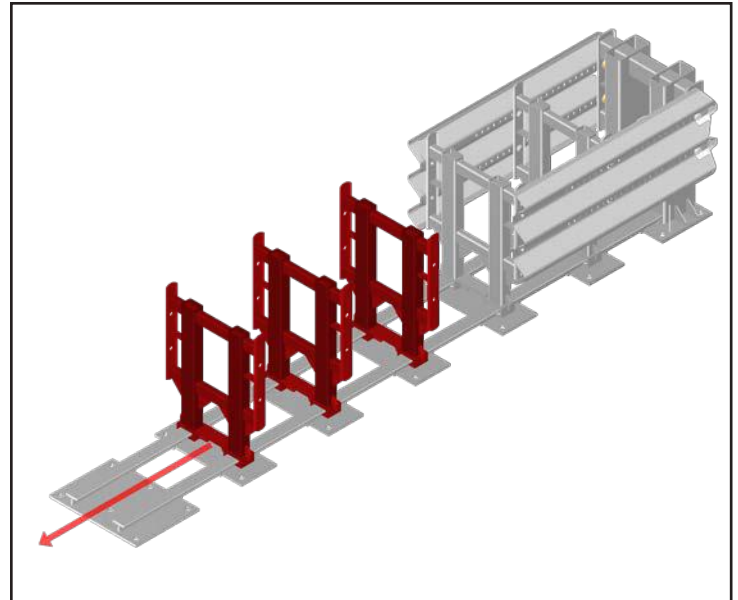

Step 7

Once all damaged fender panels and diaphragms have been removed, they shall be recycled.

! **NOTE:** Refer to Page 8 for dismantling and recycling instructions.

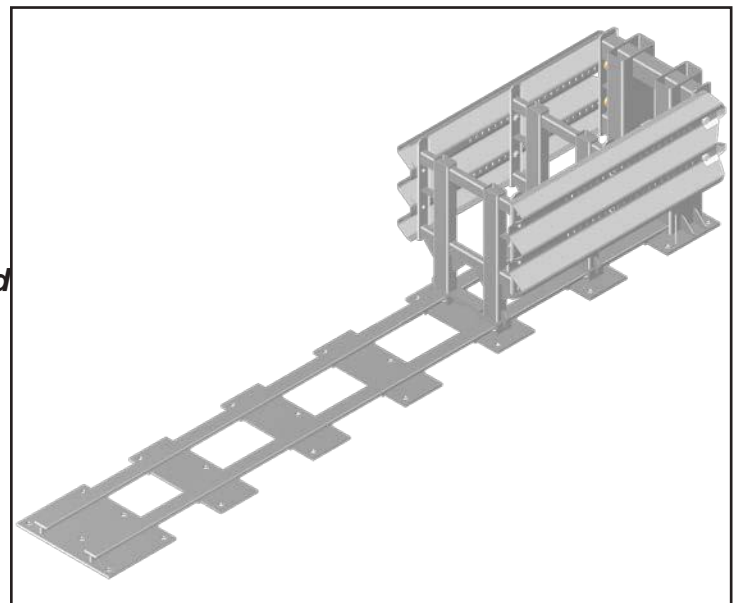



Frontal Compression

Removing damaged Attenuation Module and Fender Panels from a front impact.



Step 1

Loosen and remove the wing washers from the rear most damaged fender panel. This will detach all damage fender panels from the track.

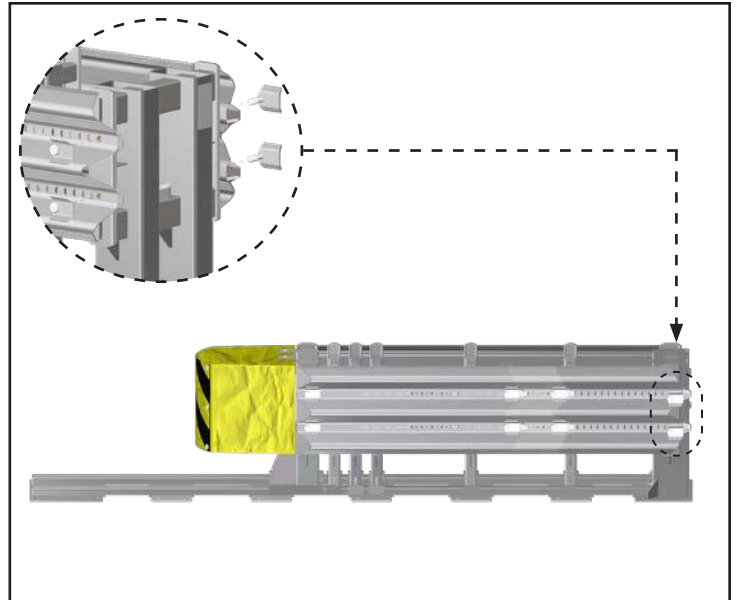

Step 2

Remove any debris from the track. Loop chain around Front Impact Head Diaphragm, pull the damaged components forward and off the track.

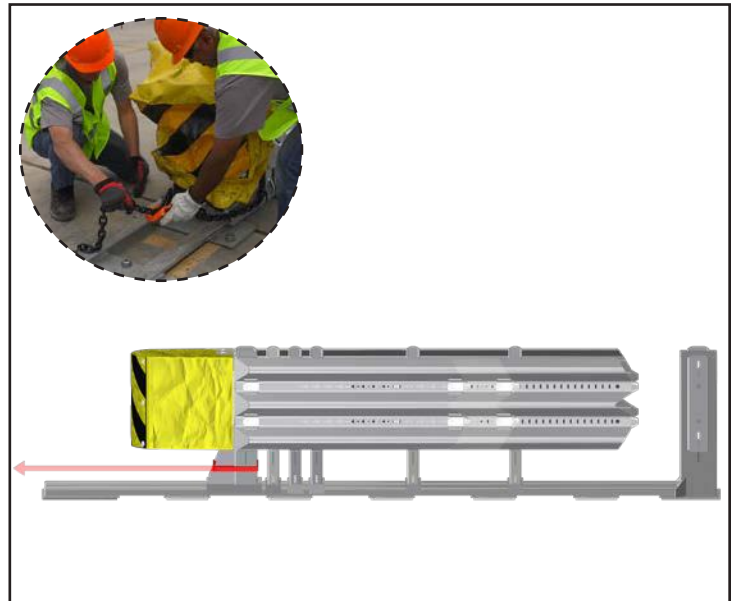

Step 3

Once the damaged components are off the track, remove chain looped around Front Impact Head Diaphragm. Insert forklift blades through the center of the diaphragms, pick up and put onto truck.

NOTE: *Caution* floating diaphragms may fall when lifted. Under **NO** circumstances should anyone stand under suspended load. Always keep a clear line of sight on suspended loads.

Refer to Page 8 for dismantling and recycling instructions.

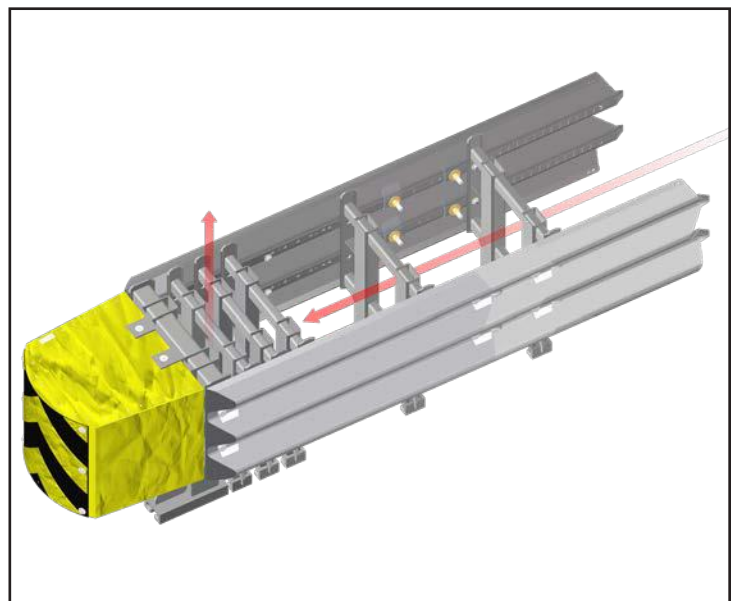

! **NOTE: STAY OUT FROM UNDER SUSPENDED LOADS.**

This Page Intentionally Left Blank

Section 3: Installing New Parts

System Rebuild



! Attention! Read and Understand.



NOTE:
The Fender Panels identification number is located on the trailing edge corner of each panel.



NOTE:
Trailing edge on the panels must face the rear end of the system.

! Attention! Read and Understand.

NOTE:
When installing the Fender Panels, every other diaphragm will be secured with wing washers.

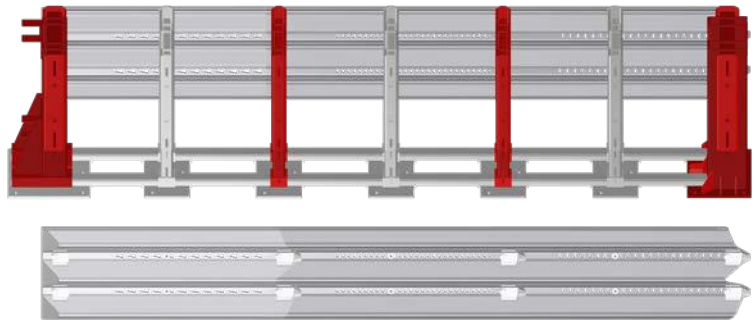
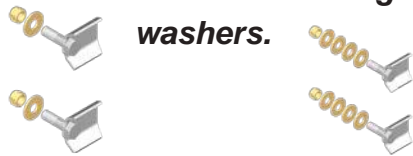

! Attention! Read and Understand.

Correct



NOTE:
Wing Washers must be installed with the long end facing the rear end of the system.

Incorrect



! Attention! Read and Understand.

NOTE:
The sacrificial hardware assembly consists of one (1) bolt, two (2) washers, and one (1) nut. The floating diaphragm requires two assemblies per side.

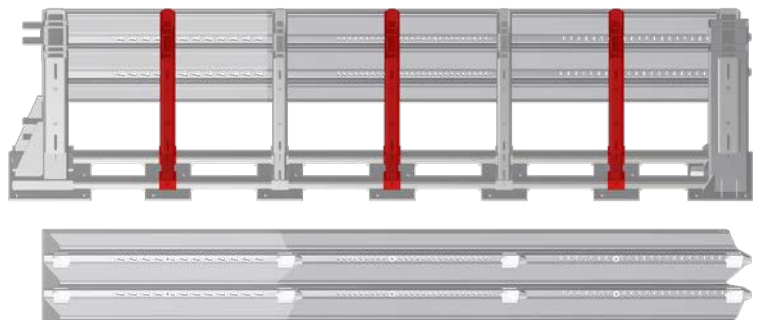

Preparation

Lay parts in order to make installation fast and easy. You must have the following parts:

- (1) Track
- (5) Diaphragms
- (1) Front Impact Head Diaphragm
- (2) Fender Panel 45N
- (2) Fender Panel 3N
- (2) Fender Panel 1N
- (1) Front Attenuation Module (4 Bolts & 4 Washers)
- (16) Wing Washer Assembly (40 Washers & 16 Nuts)
- (12) Sacrificial Bolt Assembly (24 Washers & 12 Nuts)

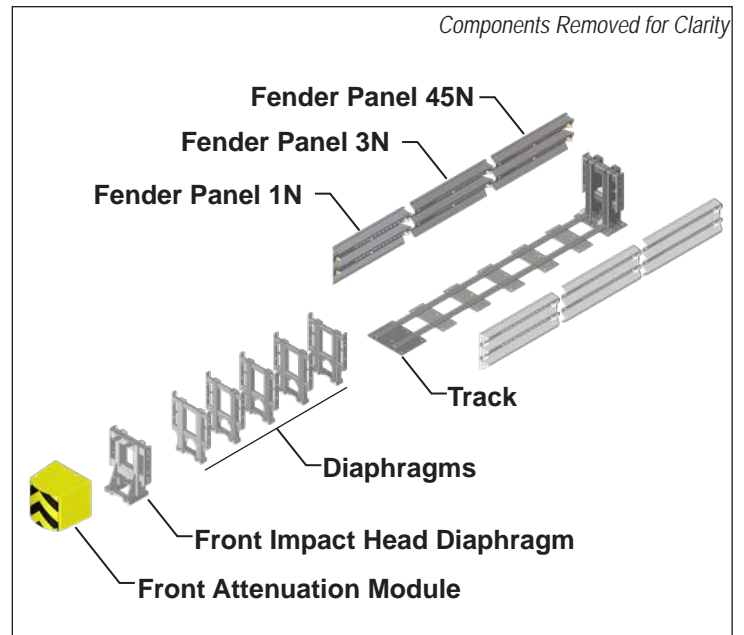

Step 1

Slide five (5) diaphragms onto track with diaphragms spaced $22.25'' \pm 1''$ (565 mm).

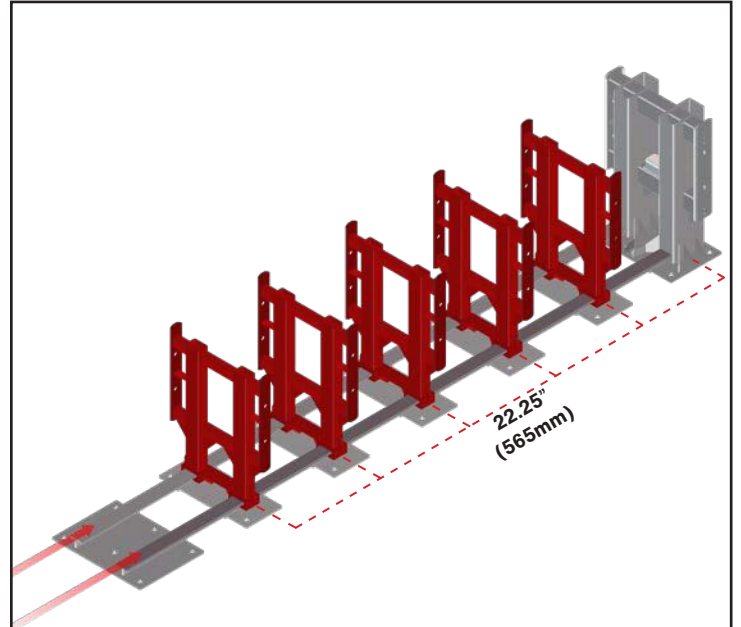

Step 2

Slide the Front Impact Head Diaphragm last (this holds the Front Attenuation Module).

NOTE: DO NOT INSTALL Front Attenuation Module, this will be a later step.

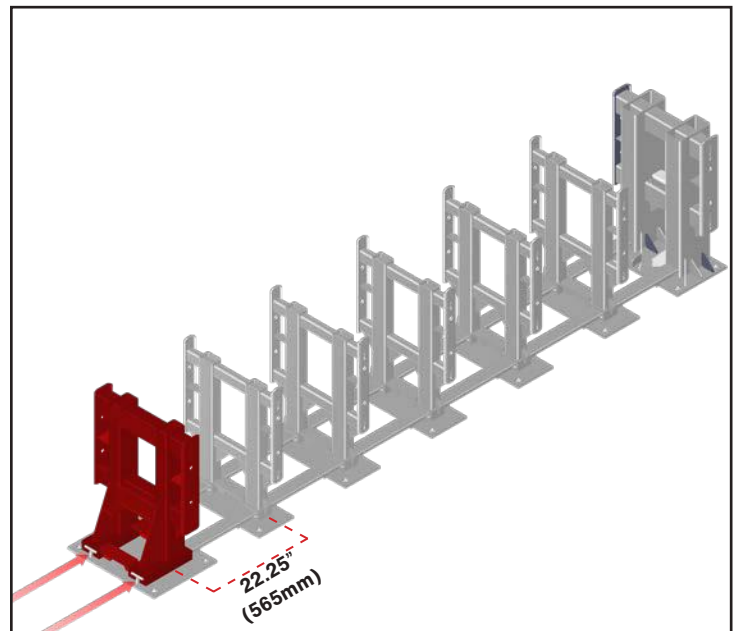

Step 3

Fender panels must be lapped under one another starting from the rear of the system.

Place Fender Panel 45N into position with the trailing edge facing the rear end of the system. Insert wing washer and install four (4) washers and one (1) nut to the trailing edge of the panel. Do not fully tighten hardware at this time.

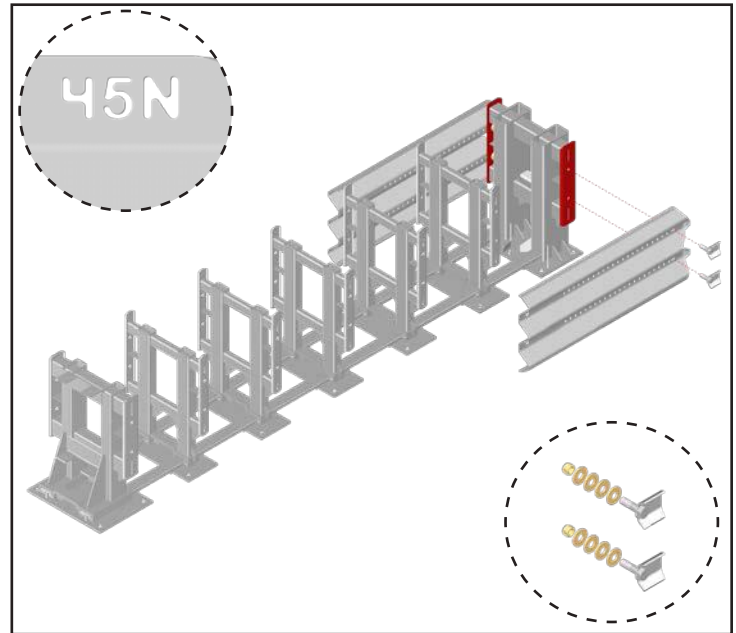

Step 4

Lift and align the loose leading edge holes of panel 45N to the trailing edge holes of panel 3N, this will lap one end of the two panels. Insert wing washer and install one (1) washer and one (1) nut to the trailing edge of the panel. Do not fully tighten hardware at this time.

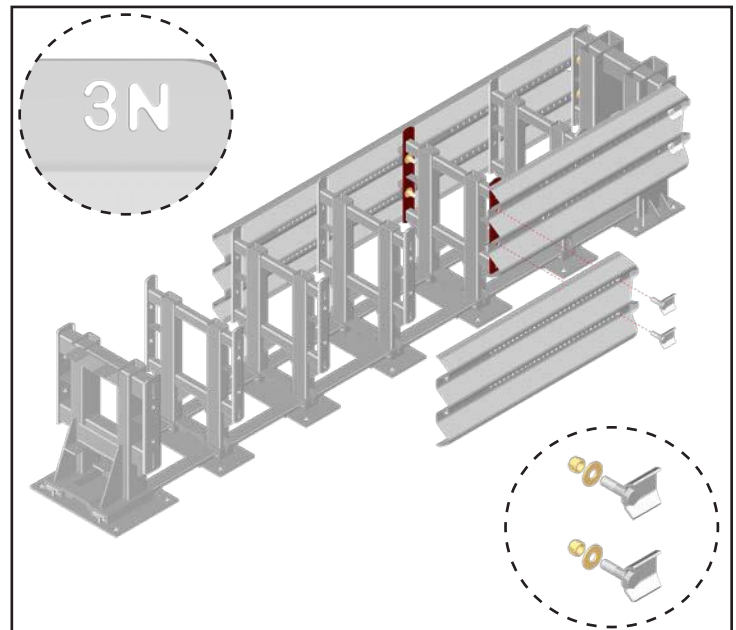

Step 5

Lift and align the loose leading edge holes of panel 3N to the trailing edge holes of panel 1N, this will lap one end of the two panels. Insert wing washer and install one (1) washer and one (1) nut to the trailing edge of the panel. Insert wing washer into the leading edge of the panel and through the impact head diaphragm mounting holes. Install four (4) washers and (1) one nut onto each wing washer, do not fully tighten hardware at this time.

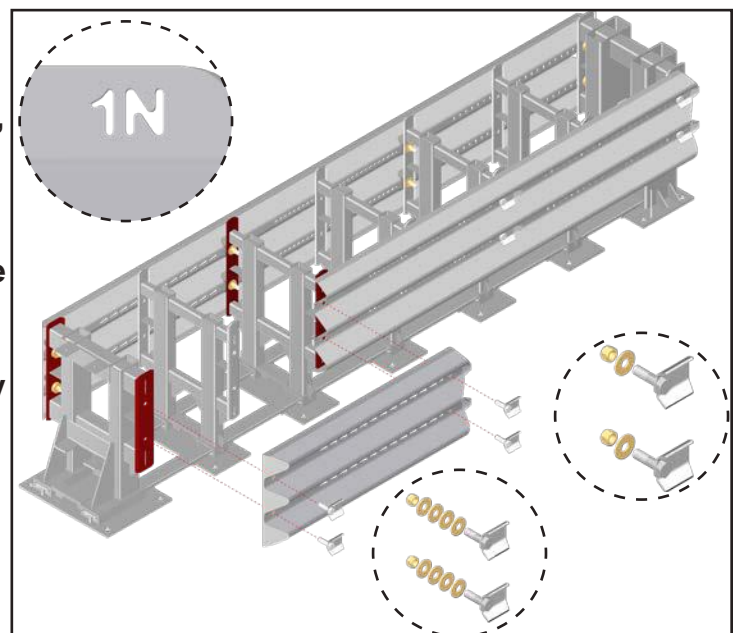

Step 6

With all Fender Panels in place. Verify wing washer orientation and washer configuration.

Correct

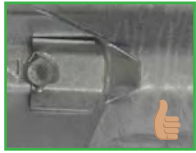

NOTE:

Wing Washers must be installed with the long end facing the rear end of the system.

Incorrect

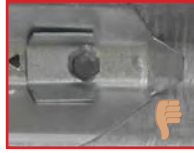

Once washer configuration and wing washer orientation has been verified and inspected, the hardware is ready to be tightened. Tighten wing washers to have 4 threads visible or approx. 1/2" (13 mm) protruding past the end of the nut. **NOTE: DO NOT Over Tighten.**

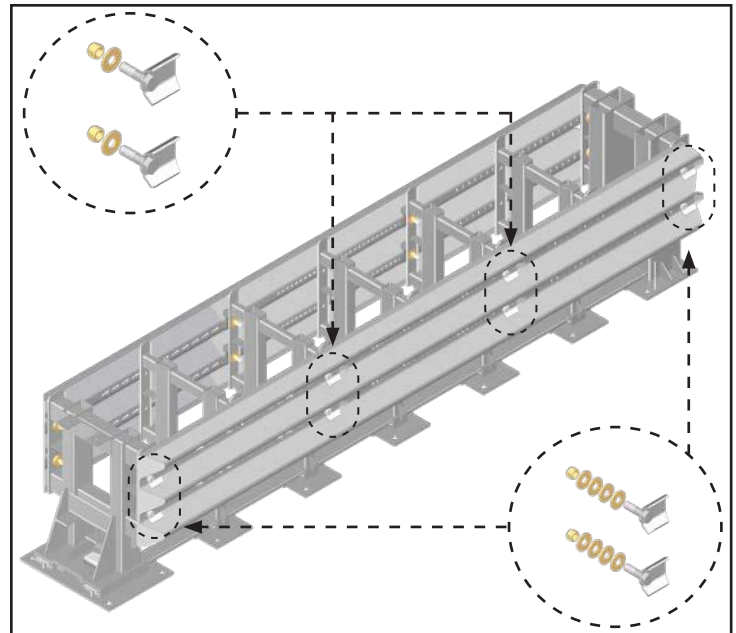

Step 7

The three (3) floating diaphragms are located between the diaphragms secured with wing washers. Position floating diaphragms to be spaced 22.25" ± 1" (565mm) from the secured diaphragms.

NOTE: Still unsure about the placement of the floating diaphragms? You can align the diaphragms using the fender panel cutouts. As shown below.

Fender Panel 1N - 5th Pattern Cutout



Fender Panel 3N - 11th Pattern Cutout



Fender Panel 45N - 8th Pattern Cutout

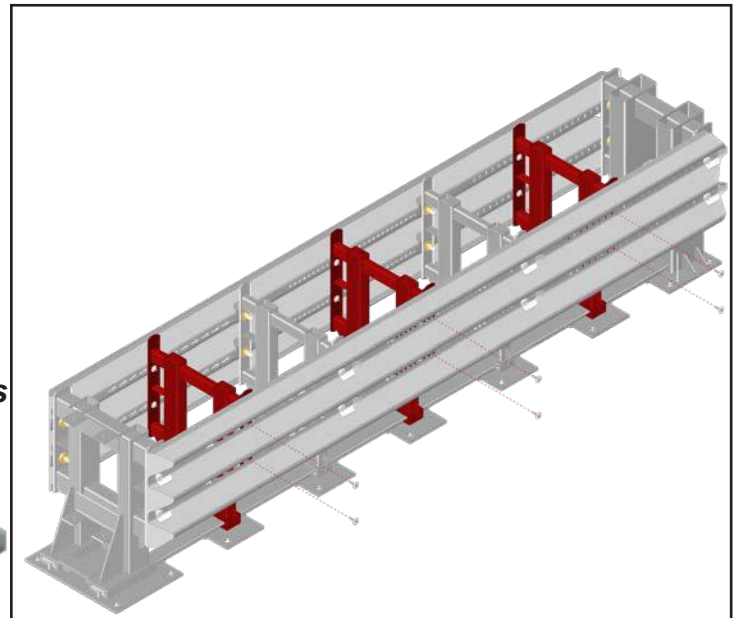

Once the floating diaphragms are centered, install sacrificial hardware to secure in place. The sacrificial hardware assembly consists of one (1) bolt, two (2) washers, and one (1) nut. The floating diaphragms requires two assemblies per side. Tighten bolts so that the diaphragm is centered between the fender panels and the washers do not rotate freely. **NOTE: DO NOT Over Tighten.**

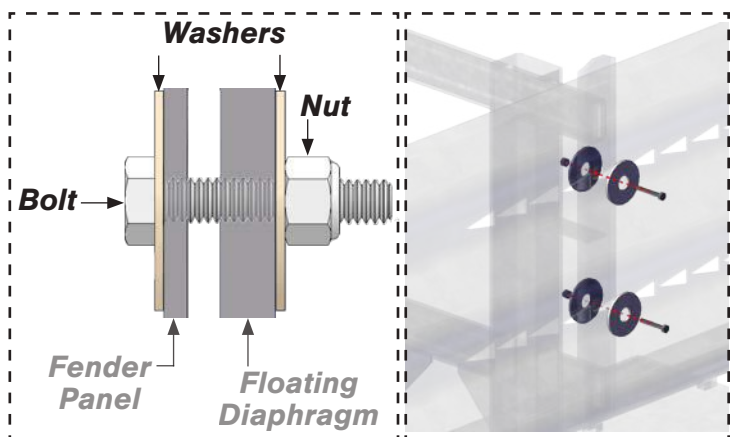

Step 8

Use a lubricant or grease to prep the top and bottom holes. Lift the Front Attenuation Module into position by aligning the back openings with the Front Impact Head Diaphragm gussets.

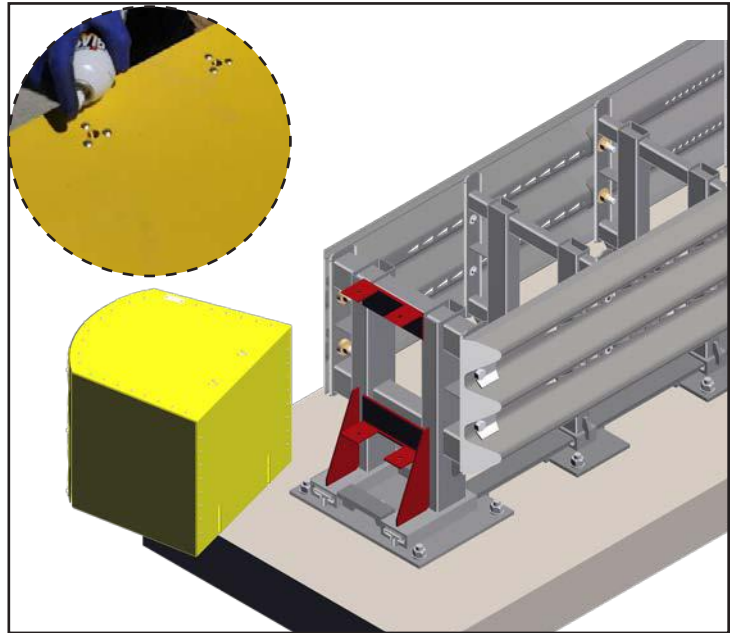

Step 9

Once Front Module is in position, secure (4) bolts and (1) washer per bolt, on top of the module and under the module. Tighten to a minimum of 6 ft-lbs (8.14 Nm).

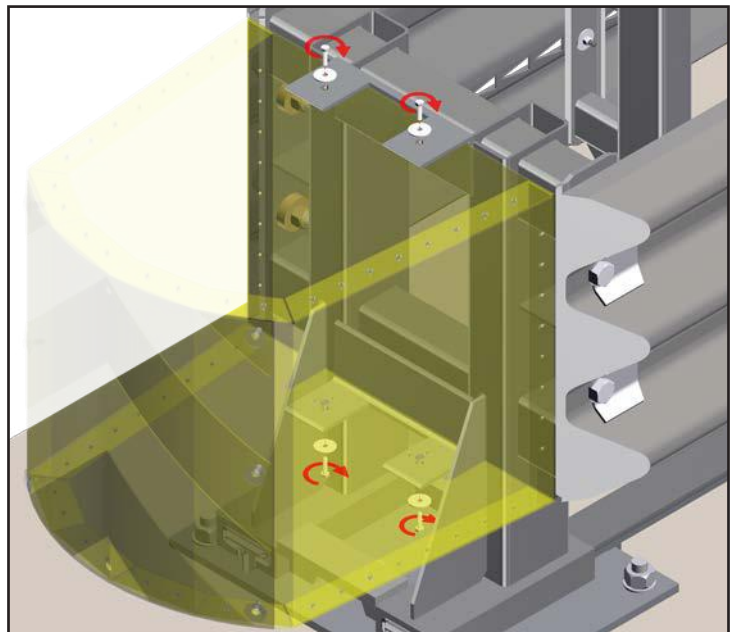

Step 10

The nose sheeting has been provided as a way to easily customize field use. The diagonal stripes used on the Left Hand Traffic Flow can be rotated 90 degrees for Right Hand Traffic Flow. Turn the sheeting over and it is used for Gore Point Traffic Flow. To determine the correct nose sheeting side follow state regulations and installation location. Once the direction is determined, secure the sheeting to the front attenuation module with supplied bolts using a 7/16" socket.

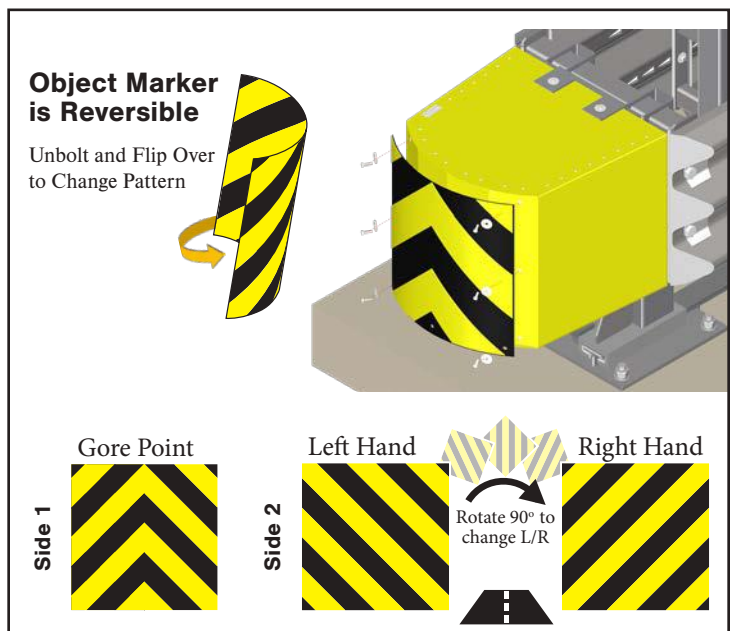

Transition Installation



TDI Bridge Shoe Transition

Step 1

Remove rear wing washers, washers and nuts from rear fender panel (45N). Remove sacrificial hardware. Loosen nuts from wing washers. Once the hardware on fender panel (45N) has been removed, pull the panel outward.

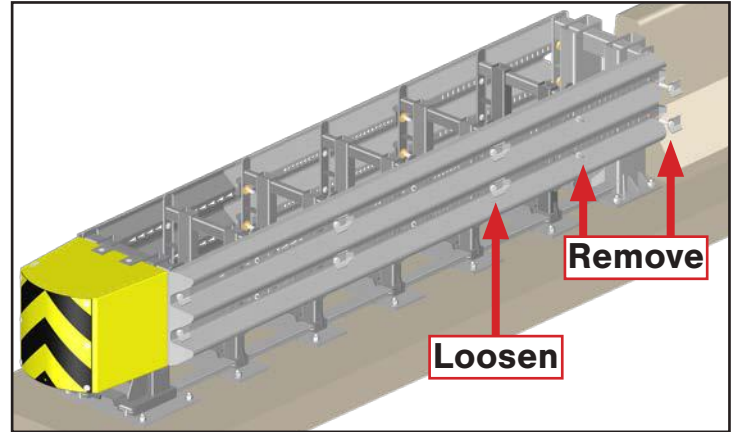

Step 2

Once transition is lapped under and is in alignment with rear fender panel (45N) insert wing washers to hold transition in place. Proceed to install and tighten wing washers and sacrificial hardware from Step 1.

Correct

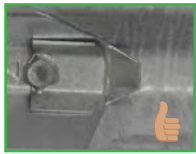

NOTE:

Wing Washers must be installed with the long end facing the rear end of the system.

Incorrect

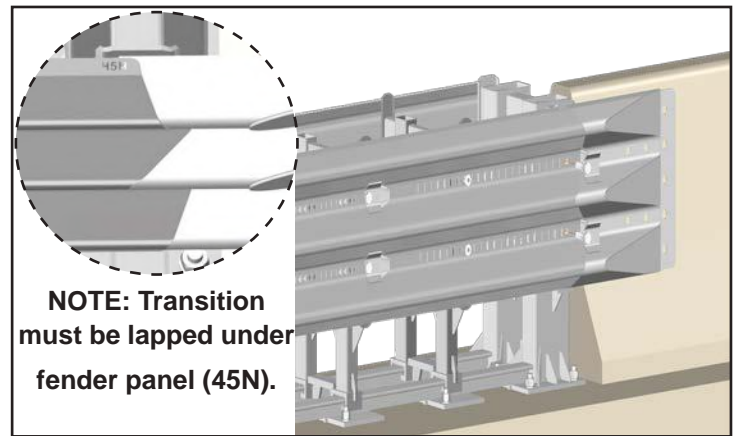
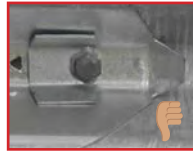

Mark drill bit to the length of the anchor bolt. Use trailing edge holes on the transition as a drilling template. Drill holes to a depth of 5" (127 mm) with a rotary hammer drill and a 3/4" drill bit.



NOTE: Clean the holes after drilling.

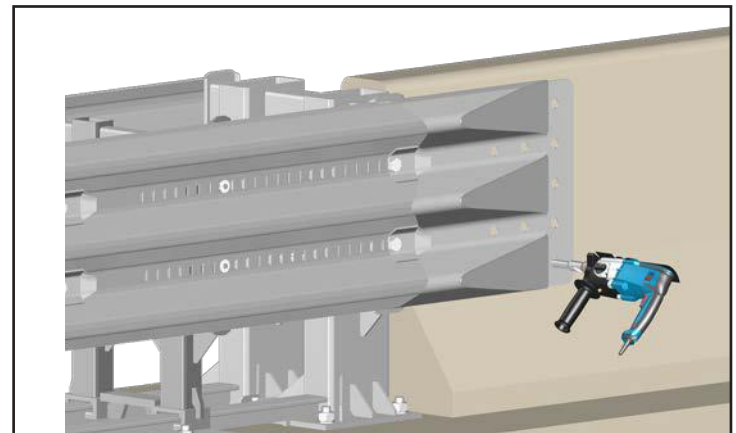

Step 4

Install the mechanical anchor bolts with an impact wrench and 1-1/8" socket. Tighten anchor bolts until the trailing edge of the transition is flush with the barrier.

⚠ NOTE: Steps 1-4 applicable for Standard Bridge Shoe installation.

⚠ User(s) has the responsibility to determine a suitable transition that must be compliant with local and state government standards.

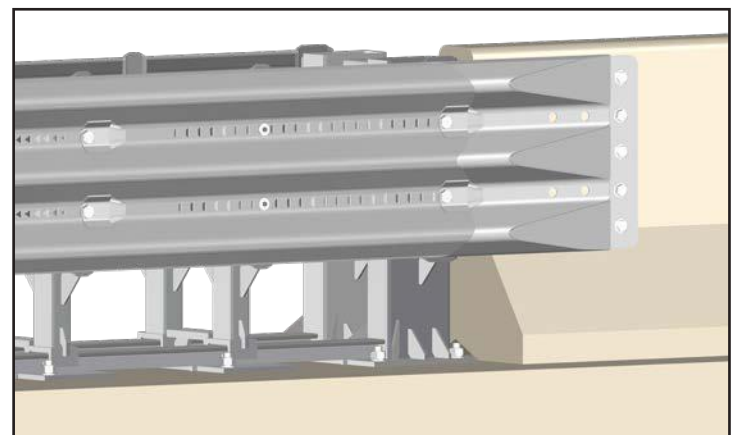

TDI Transition Panel

Step 1

Remove rear wing washers, washers and nuts from rear fender panel (45N). Remove sacrificial hardware. Loosen nuts from wing washers. Once the hardware on fender panel (45N) has been removed, pull the panel outward.

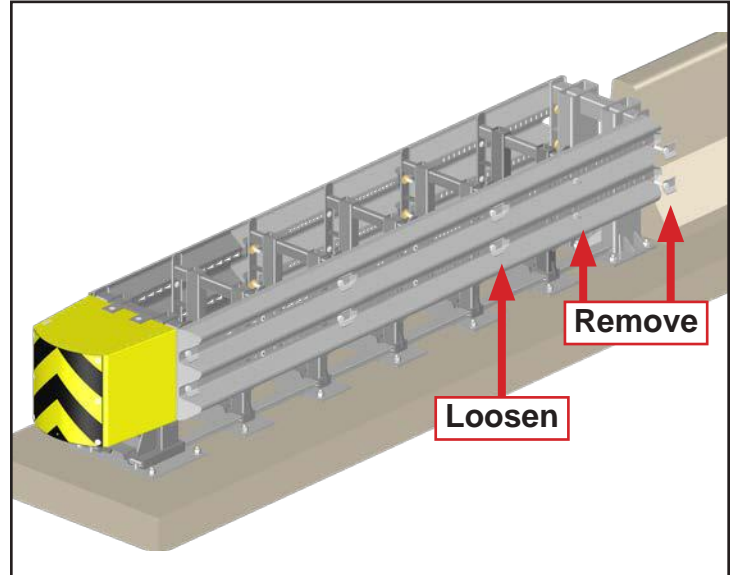

Step 2

Attach lifting strap to the J-Bolts located on the top of the transition. Once transition is lapped under and is in alignment with fender panel (45N), insert wing washers to hold transition in place. Proceed to install and tighten wing washers and sacrificial hardware from Step 1.

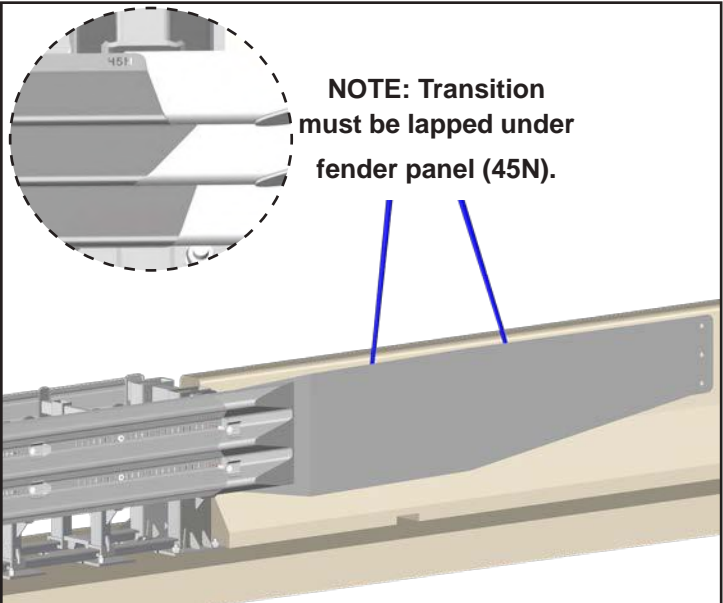

Correct



NOTE: Wing Washers must be installed with the long end facing the rear end of the system.

Incorrect



NOTE: Once in place, remove lifting strap and J-Bolts from the transition.

Step 3

Mark drill bit to the length of the anchor bolt. Use trailing edge holes on the transition as a drilling template. Drill holes to a depth of 5" (127 mm) with a rotary hammer drill and a 3/4" drill bit.



NOTE: Clean the holes after drilling.

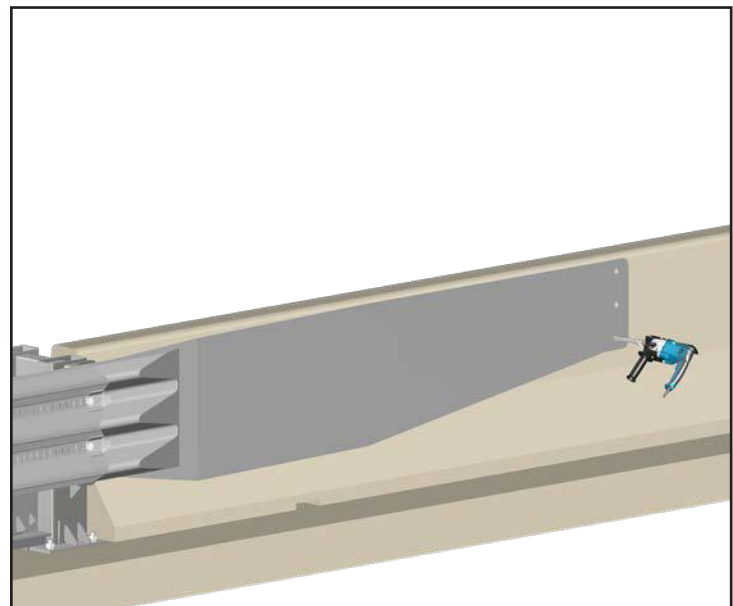

Step 4

Install the mechanical anchor bolts with an impact wrench and 1-1/8" socket. Tighten anchor bolts until the trailing edge of the transition is flush with the barrier.

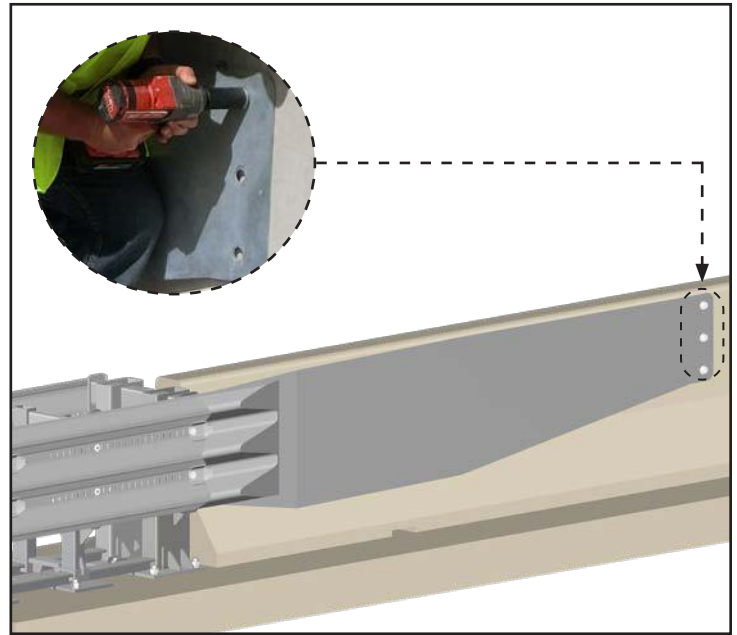

Step 5

Align first wood block to the transitions leading edge C-channel. A standard blockout is 6" (150 mm) wide, making the center of the first block 3" (75 mm) from the leading edge of the C-channel. Mark C-channel with center location of the first wood block.

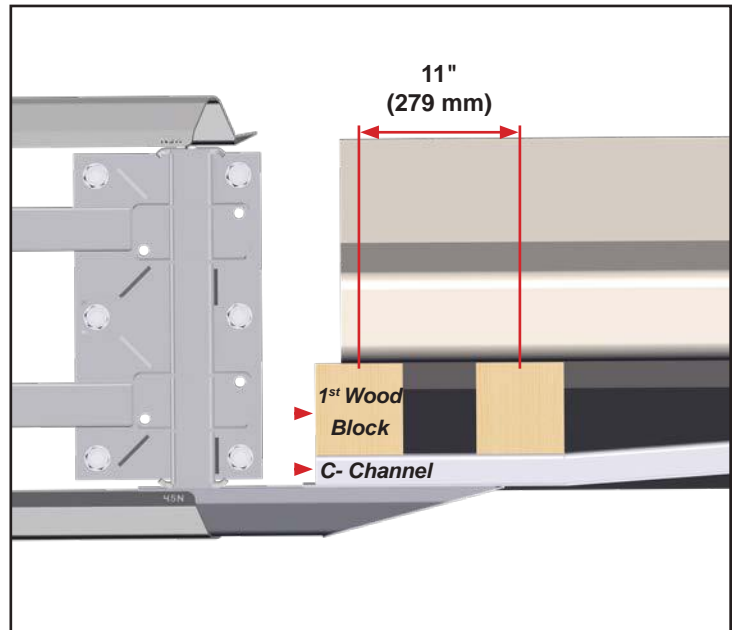

Step 6

Once the center of the first wood block has been determined, use the dimensions shown to locate the center of the remaining blocks. Mark the center location of each block on the C-channel. Once the center of the blocks have been located measure the top and bottom opening from the C-channel to the barrier. This will help determine the angle to cut when field trimming the wood blocks. Mark each block with the top and bottom opening dimension and field trim blocks. Place wood blocks in position once trimming complete.

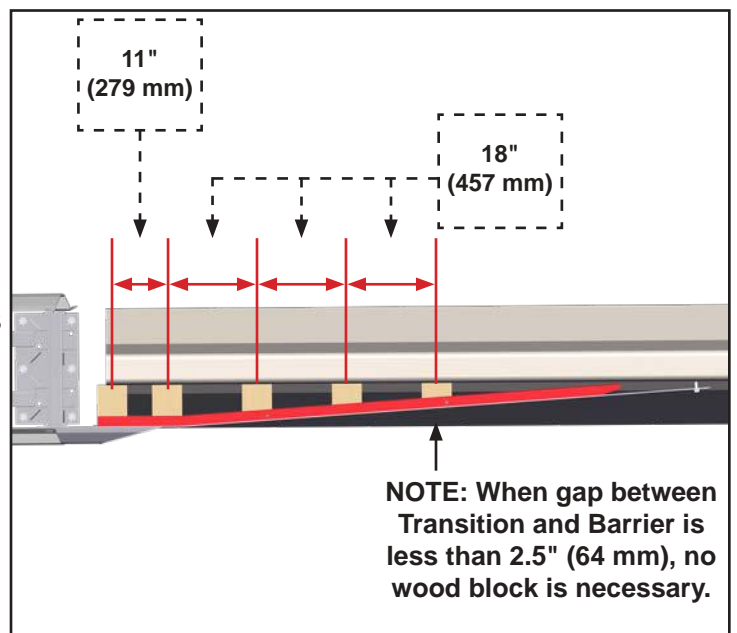

Step 7

Place a blockout holder on each wood block. Center the blockout holders on the wood blocks with the long edge parallel to the barrier. Use the blockout holder as a drilling template to pre drill pilot holes in the transitions C-Channel and the wooden blocks.

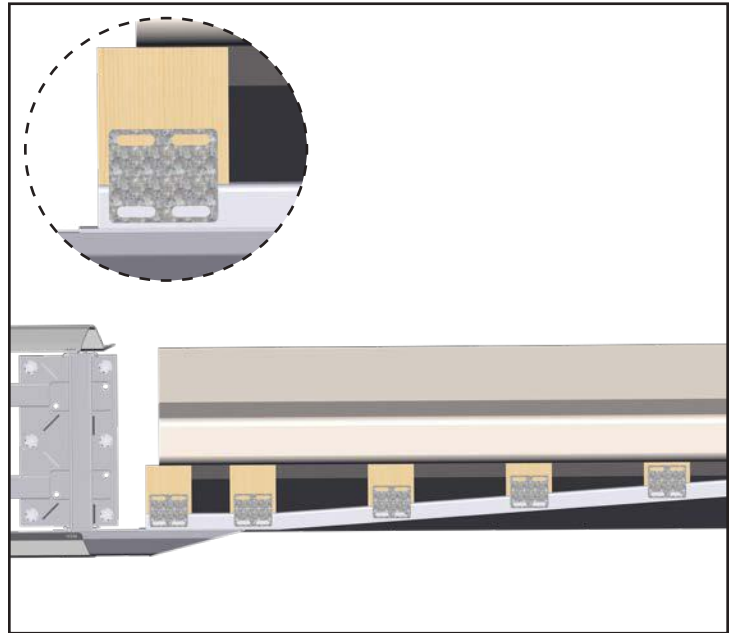
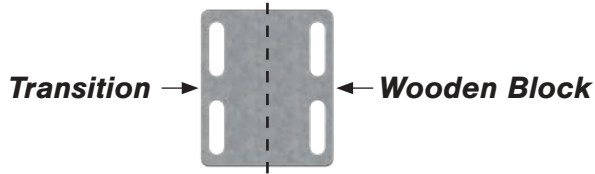

Step 8

The self-tapping screws go on the C-channel side. Wooden lag bolts go into the wood blocks. Once the self-tapping screws and wooden lag bolts are inserted, tighten with an impact driver to secure the blockout holder plate.

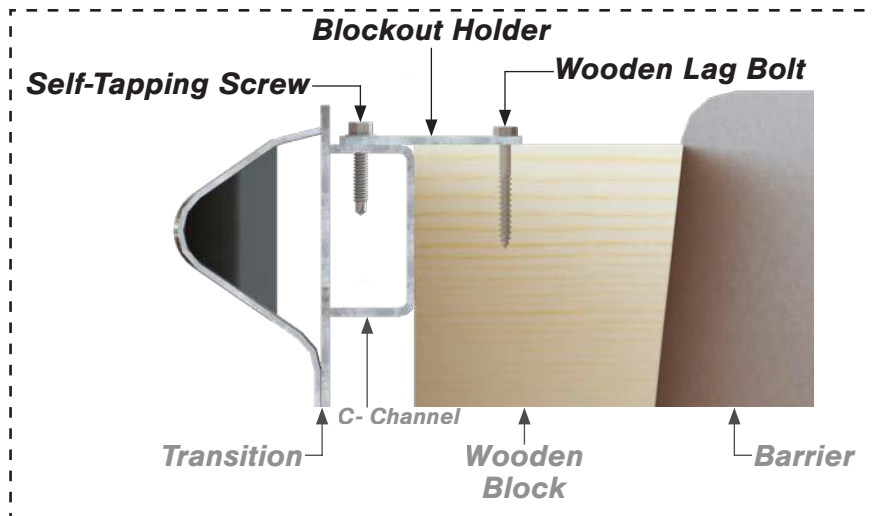
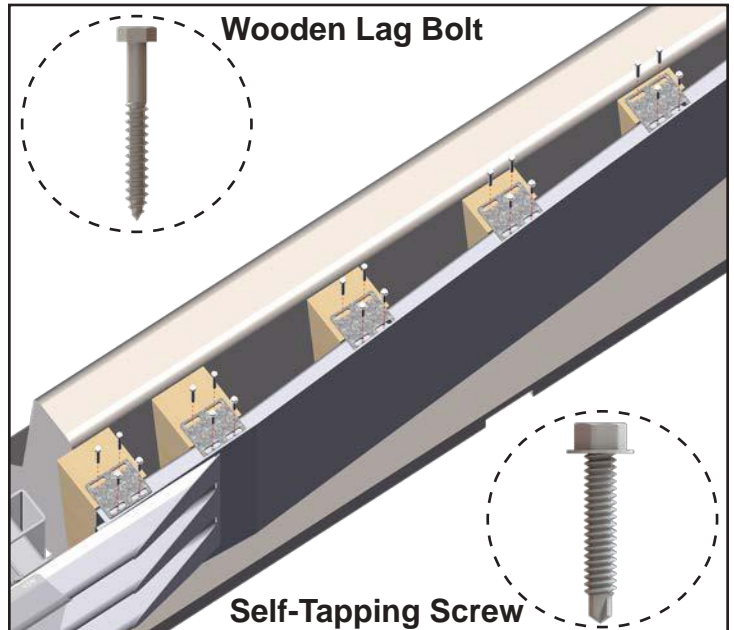

This Page Intentionally Left Blank

Serial Number

Date of Installation: _____

Location: _____

Condition of Delta: _____



TrafFix Devices Inc.
SN **DXXXXX**
Serialized Component

Front Attenuation Module Serial Number:

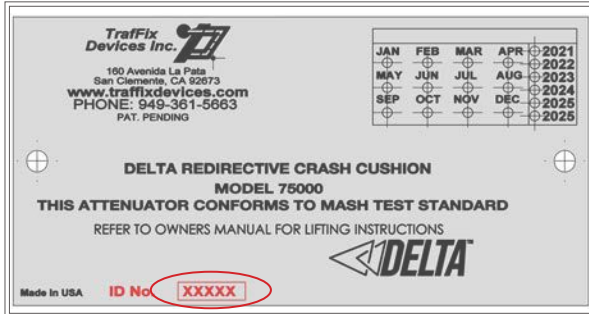

TrafFix Devices Inc.
100 Avenida La Pata
San Clemente, CA 92673
www.traffixdevices.com
PHONE: 949-361-5663
PAT. PENDING

JAN	FEB	MAR	APR	2021
MAY	JUN	JUL	AUG	2022
SEP	OCT	NOV	DEC	2023
				2024
				2025

DELTA REDIRECTIVE CRASH CUSHION
MODEL 75000
THIS ATTENUATOR CONFORMS TO MASH TEST STANDARD
REFER TO OWNERS MANUAL FOR LIFTING INSTRUCTIONS



Made in USA ID No. **XXXXXX**

Track Serial Number:



www.traffixdevices.com
(949) 361-5663



This device complies with Part 15 of the FCC Rules and Industry Canada's license-exempt RSS standards. Operation is subject to the following two conditions: (1) this device may not cause interference, and (2) this device must accept any interference, including that which may cause undesired operation of the device.

Contains FCC ID: _____ Contains IC: _____ **Serial Number:** _____

Sentinel Serial Number:

Inspection Checklist

<u>Items to Inspect</u>	
27 Anchor Bolts are Installed	
27 Anchor Bolts Do Not Exceed .5 in (13 mm) Past Anchor Nut	
27 Anchor Bolts are Properly Torqued. Concrete Installations 100 ft- lbs (135 Nm). Asphalt Installations 10 ft-lbs (14 Nm)	
All Diaphragms are Spaced 22.25" ± 1" If Spacing Falls out of Spec the Diaphragms with the Sacrificial Hardware shall be Adjusted.	
Rear Fender Panels can Telescope Rearward 35" (889 mm) without Obstruction	
All Wing Washers are the Correct Orientation	
Check all Factory Hardware	
Front Attenuation Module is Installed with 4 Fasteners	
Front Attenuation Module has Proper Sheeting for the Site	
All Tools and Debris are Cleared from Delta	
Serial Numbers have been Documented	

Inspected By: _____

Contact Information: _____ Date: _____

Notes

Notes

+ INTRODUCING TDI'S NEW PAPERLESS

Product Knowledge Base

In an effort to cut down on our paper waste and make sure that you can easily access anything you need to know about your TDI product, we're introducing our new digital Product Knowledge Base. You'll be able to find all general and technical information about your TDI products through the simple self-serve portal.

Scan the QR code or visit the link below to start browsing resources like manuals, replacement part guides, video demonstrations, FAQs + more!

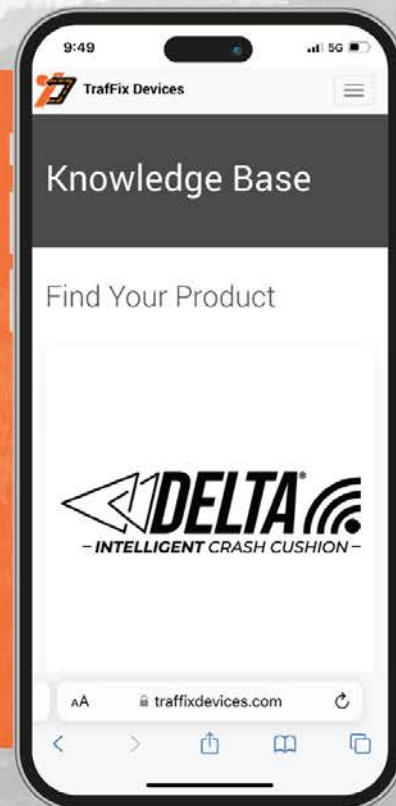
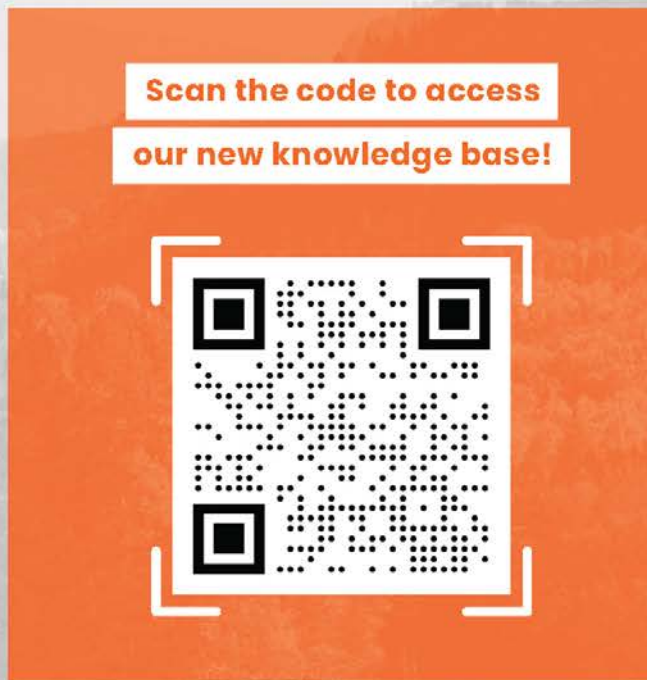

Or visit www.traffixdevices.com/KB

from your computer, tablet, or mobile device!

+ INTRODUCING THE SIGNIFICANTLY SIMPLE

DELTA Crash Cushion Online Training Course

Want to become an expert on the innovative DELTA Crash Cushion? TDI is now offering a **completely free online training course** that will teach you and your team all of the ins and outs of the DELTA's installation, repair, and maintenance process. The course is just as simple as the DELTA's innovative design and **can be completed in as little as an hour**. Even after completion, the course becomes an invaluable resource that can be accessed for reference in the field.

Sound like something for your team? Follow these steps to sign up:

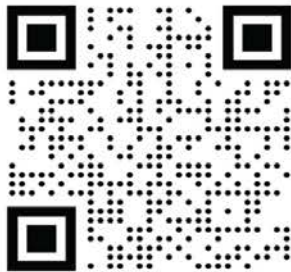

**Scan for access to
TDI University**

1. Scan the QR code or visit <https://go.bluevolt.com/TraFFix/s/> to access the Traffix University home page.
2. Sign up and apply for the DELTA training course.
3. Once your application has been approved, simply complete the course modules and assessments through the university portal on your PC, tablet, or smart phone.
4. Earn your completion badge and wear it proudly!



Regional Sales Manager

<p>Northeast Territory Office VA, WV, DE, MD, NJ, NY, PA, CT, MA, RI, NH, VT, ME, D.C. Mike Herlehy (585) 267-9970 Office (949) 573-9239 Fax mherlehy@traffixdevices.com</p>	<p>Southeast Territory Office TN, NC, SC, GA, MS, AL, FL Lary Hudoff (770) 778-8281 Office (949) 325-6059 Fax lhudoff@traffixdevices.com</p>
<p>Northwest Territory Office MT, UT, ID, WA, OR, NV, CO, WY Cary LeMonds (801) 979-7099 Office (949) 573-9290 Fax clemonds@traffixdevices.com</p>	<p>Midwest Territory Office OH, MI, IN, KY, IL, WI, MN, ND, SD, IA, MO Dave H. Lindquist (630) 605-1273 Office (949) 573-9240 Fax dlindquist@traffixdevices.com</p>
<p>Western Territory Office CA, HI, AK, AZ Lawrence Berg (949) 350-7048 Office (949) 573-9267 Fax lberg@traffixdevices.com</p>	<p>Southwest Territory Office TX, OK, KS, NE, NM, AR, LA John Gense (214) 704-1476 Office (949) 573-9291 Fax jgense@traffixdevices.com</p>
<p>Chief Revenue Officer Chris Giordano (216) 233-3273 Office (949) 573-9264 Fax cgiordano@traffixdevices.com</p>	<p>To Place Orders Email: orders@traffixdevices.com Office: (949) 361-5663 Fax: (949) 573-9250</p>

Customer Support Services

TraFFix Devices, Inc. Headquarters

160 Avenida La Pata, San Clemente, CA 92679

Email : info@traffixdevices.com

Phone: (949) 361-5663 Fax: (949) 573-9250

Hours: Monday - Friday

7:30 AM - 4:30 PM

www.traffixdevices.com

