

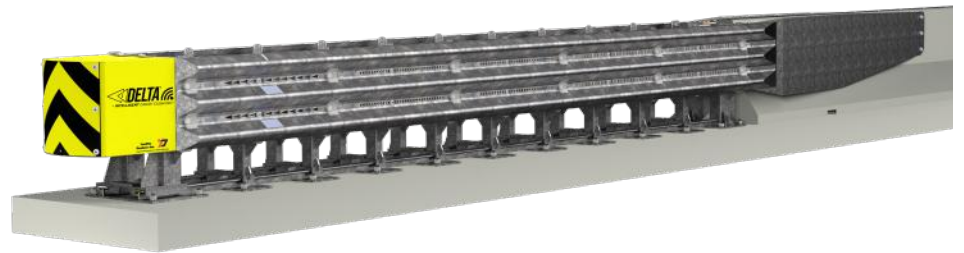

Delta[®]

Intelligent Crash Cushion Installation Guide

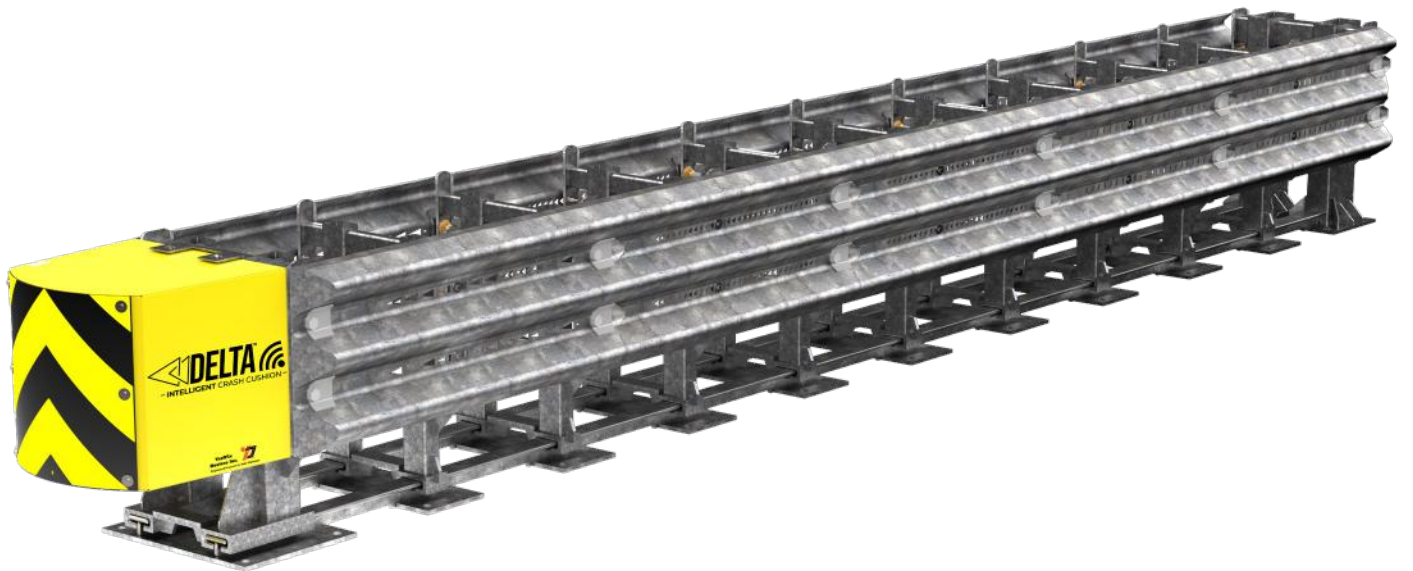















Introduction to Guide

 **Important:** These instructions pertain only to the assembly and installation of the Delta® Intelligent Crash Cushion (ICC). Any deviation from the Delta ICC shown would require consultation with the appropriate highway authority Engineer and/or certified TrafFix Devices, Inc. representatives. Contact information for TrafFix Devices representatives can be found on the last page of this manual.

 Correct Installation of the Delta ICC is essential for proper performance of the system. For this reason, contacting a TrafFix Devices, Inc. Engineering Department manager for assistance installing the system is recommended. Please read this manual in its entirety before assembling or installing the Delta ICC. The information in this Manual supersedes all previous versions and manuals, with updated illustrations and other information available at time of printing; however; TrafFix Devices, Inc. reserves the right to make changes at any time. For any questions on proper Installation and Operation of the Delta ICC, please contact us at (949) 361-5663 or email info@traffixdevices.com.

 **Important:** This manual applies to the Delta ICC by TrafFix Devices, Inc. It pertains only to the model referenced herein. It requires that all installation, service and repair parts be genuine Original Equipment Manufacturer (OEM) Delta ICC parts that have not been modified or repaired from the original factory design.

Safety Symbols

	Attention! Read and Understand.
	Proceed with Caution.
	Hard Hat Protection Required.
	Hearing Protection Required.
	Safety Glasses or Safety Goggles Required.
	Dust Mask Required. Dust Hazard, wear appropriate dust mask in this area.
	Safety Gloves Required.
	Safety Shoes Required.
	Tip Over Hazard. Do not move this equipment without mechanical assistance.
	Pinch point. Keep hands clear during operation.
	Crush Hazard. Keep feet clear.
	Forklift Required. Caution Forklift Operating.
	Warning Overhead Crane. Stay out from under suspended loads.
	Danger! Toxic Hazard. Do not get on skin, eyes or clothing.



NOTE: The safety symbols list provided is a general recommendation and should not be considered an all-inclusive list. Always follow best practice.



Table of Contents

Warning and Limitations	05
Warranty	06
Overview, Product Description	08
Delta ICC Orientation	09
Lifting Points	10
System Dimensions	11
Pre-Installation	12
Product Placement	13
Installation Site, Cross-Slope	14
Transition Installation	15
Transition	16
Tools Required	17
Sentinel Activation	19
Installation	20
Nose Sheeting Installation	27
Serial Numbers	28
Inspection Checklist	29
Maintenance	30
Delta Replacement Parts	31
Appendix	34
Contact Information	46

Warning and Limitations

TraFFix Devices Inc. (TDI), in compliance with the Manual for Assessing Safety Hardware (MASH) recommended procedures for the Safety Performance of Highway Features. TDI contracts with ISO accredited testing facilities to conduct crash tests, evaluation of tests, and submittal of results to the Federal Highway Administration for Eligibility for Federal-Aid Reimbursement. The Delta[®] Intelligent Crash Cushion (ICC) was tested to meet the safety evaluation guidelines of MASH. The Delta ICC has been tested at TL-3 (62.1 mph/ 100 km/hr) impact speed conditions. These tests are intended to evaluate product performance by simulating those impacts outlined by MASH involving a range of vehicles on the roadways, from cars with an approx. weight of 2425 lbs [1100 kg] to trucks with an approx. weight of 5004 lbs [2270 kg]. The Delta ICC is a TL-3 tested device capable of decelerating and stopping the light and heavy weight vehicles 2425 lbs [1100 kg] and 5004 lbs [2270 kg] in accordance with the criteria of Tests 3-30, 3-31, 3-32, 3-33, 3-34, 3-35, 3-36, 3-37 and 3-38 for TL-3 (62.1 mph/ 100 km/hr). These specified tests are not intended to represent the systems performance when impacted by every vehicle type or every impact condition existing on the roadway. This system is tested only to the test matrix criteria of MASH. TraFFix Devices does not represent nor warrant that the results of these controlled tests show that vehicle impacts with the products in other conditions would necessarily avoid injury to person(s) or property. Impacts that exceed the system's specifications may not result in acceptable crash performance as outlined in MASH; relative to structural adequacy, occupant risk, and vehicle trajectory. TDI expressly disclaims any warrant or liability for injury or damage to person(s) or property resulting from any impact, collision, or harmful contact with products, other vehicles, or nearby hazards or objects by any vehicle, object or person, whether or not the products were installed by third parties. The Crash Cushion system is intended to be assembled, installed and maintained in accordance with specific State and Federal guidelines. TDI offers a directional object marker for the Delta ICC. However, the material is only intended to supplement delineation required by the Department of Transportation's "Manual on Uniform Traffic Control Devices" (MUTCD). The appropriate highway authority approved engineer should be careful to properly select, assemble, and maintain the product. Careful evaluation of the speed, traffic direction, and visibility are some of the elements that require evaluation for the proper selection of a safety appurtenance by the appropriate specifying highway authority.



Warranty

TrafFix Devices warrants to the purchaser that the Delta® Intelligent Crash Cushion (ICC) is free from any defects in materials and workmanship. If this product proves to be defective in material or workmanship during the period of this warranty, TrafFix Devices will repair or replace, at its discretion, the defective product free of charge. The period of this warranty is one-year beginning from the date the purchaser puts the unit into service or one-year from the date of purchase.

To obtain warranty service, the purchaser or distributor must first photograph the unit in question, fill out a warranty authorization form (Pg.7) and email TrafFix Devices to have our Engineering Department evaluate the problem and recommend repair procedures. TrafFix Devices will then issue a signed warranty work approval form to authorize the distributor or customer to repair or replace any items, which TrafFix Devices deems to have been defective. All replacement parts claimed to be defective will be invoiced at the time of shipment, and upon returned and evaluation of defective parts a credit memo will be issued.

This warranty does not extend to any failure of the Delta ICC caused by misuse, abuse, material alteration, non-OEM components, or any negligence in connection with the installation, service, or use of this product. For the correct installation, service, or use of this product refer to the installation manual, and the operator's checklist.

Warranty Authorization Form

Company Name: _____

Address: _____

Phone: _____ Fax Number: _____

Email: _____

Name of Customer: _____

Date: _____

Serial Number: _____

Replacement and Repair Parts Listed Below? _____

List Part Numbers of Replacement or Repair Items:

Describe the Problem and Reason for Failure:

**Email this Form along with Pictures to Traffix Devices
Email: info@traffixdevices.com Phone: (949) 361-5663**

Overview

The Delta ICC is a Non-Gating Redirective crash cushion manufactured by TraFFix Devices, Inc. The Delta ICC has passed all required AASHTO MASH crash tests and can be used in Uni-Directional or Bi-Directional applications. The Delta ICC was designed to be simple and effective in protecting errant vehicles from striking a wide variety of roadside hazards. The fender panels use the standard AASHTO M-180 Thrie beam profile. Utilizing this profile allows the Delta ICC to be easily attached to standard roadside safety hardware. The Delta ICC was Co-Developed with Midwest Roadside Safety Facility (MwRSF) at the University of Nebraska-Lincoln (UNL).

Product Description

The Delta ICC redirects errant vehicles when struck along the side and when impacted at the nose, it attenuates the impacting vehicles kinetic energy. When struck on the nose of the device, the vehicle's kinetic energy is absorbed by the fender panels telescoping rearward and simultaneously shearing/tearing material in the valley's of the Thrie Beam. The cutout patterns in the valleys of the Thrie beam progressively change from the front to the rear to allow the errant vehicle to be safely brought to a controlled stop.

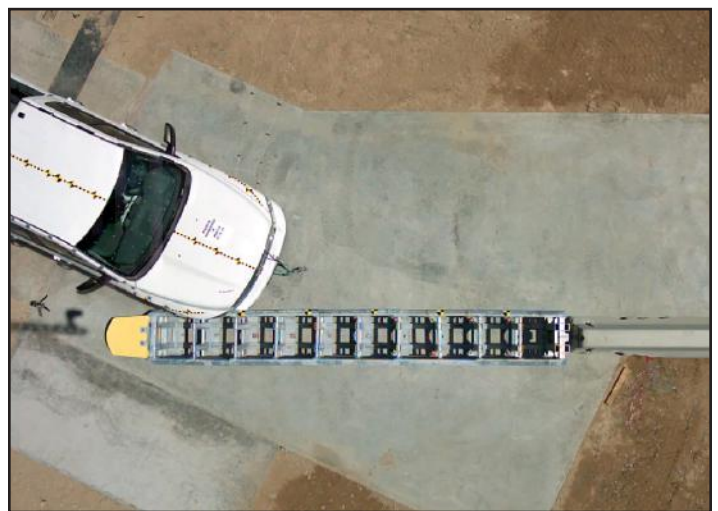

Delta Orientation

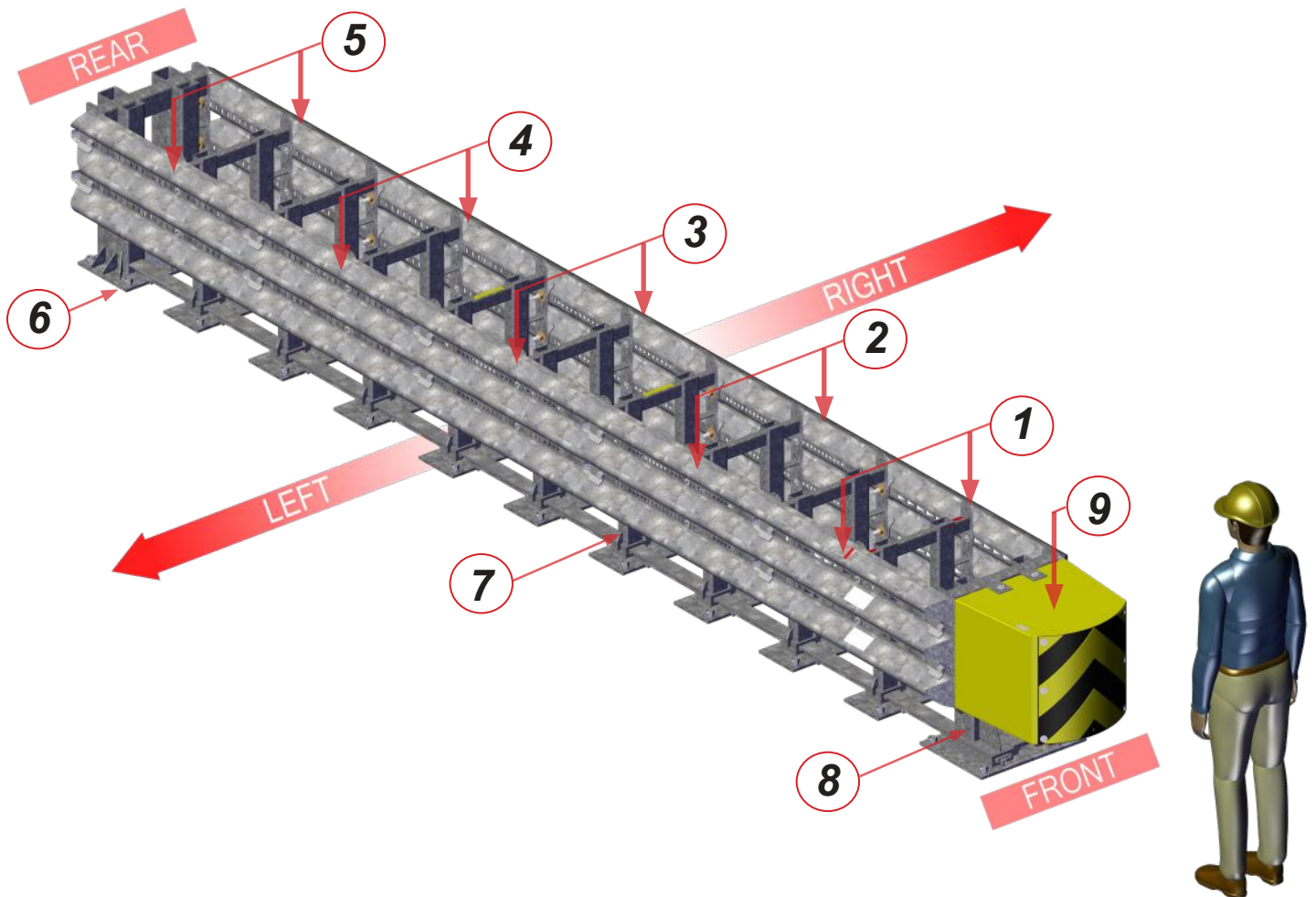

1 - Fender Panel 1N

2 - Fender Panel 2N

3 - Fender Panel 3N

4 - Fender Panel 45N

5 - Fender Panel 45N (*rear most panel*)

6 - Track

7 - Diaphragm

8 - Front Impact Head Diaphragm

9 - Front Attenuation Module

Delta Lifting Points

Acceptable Lifting Diaphragms

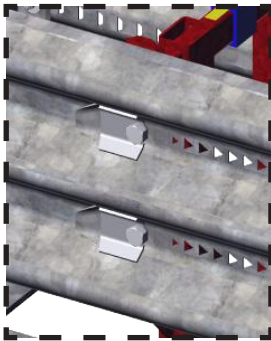
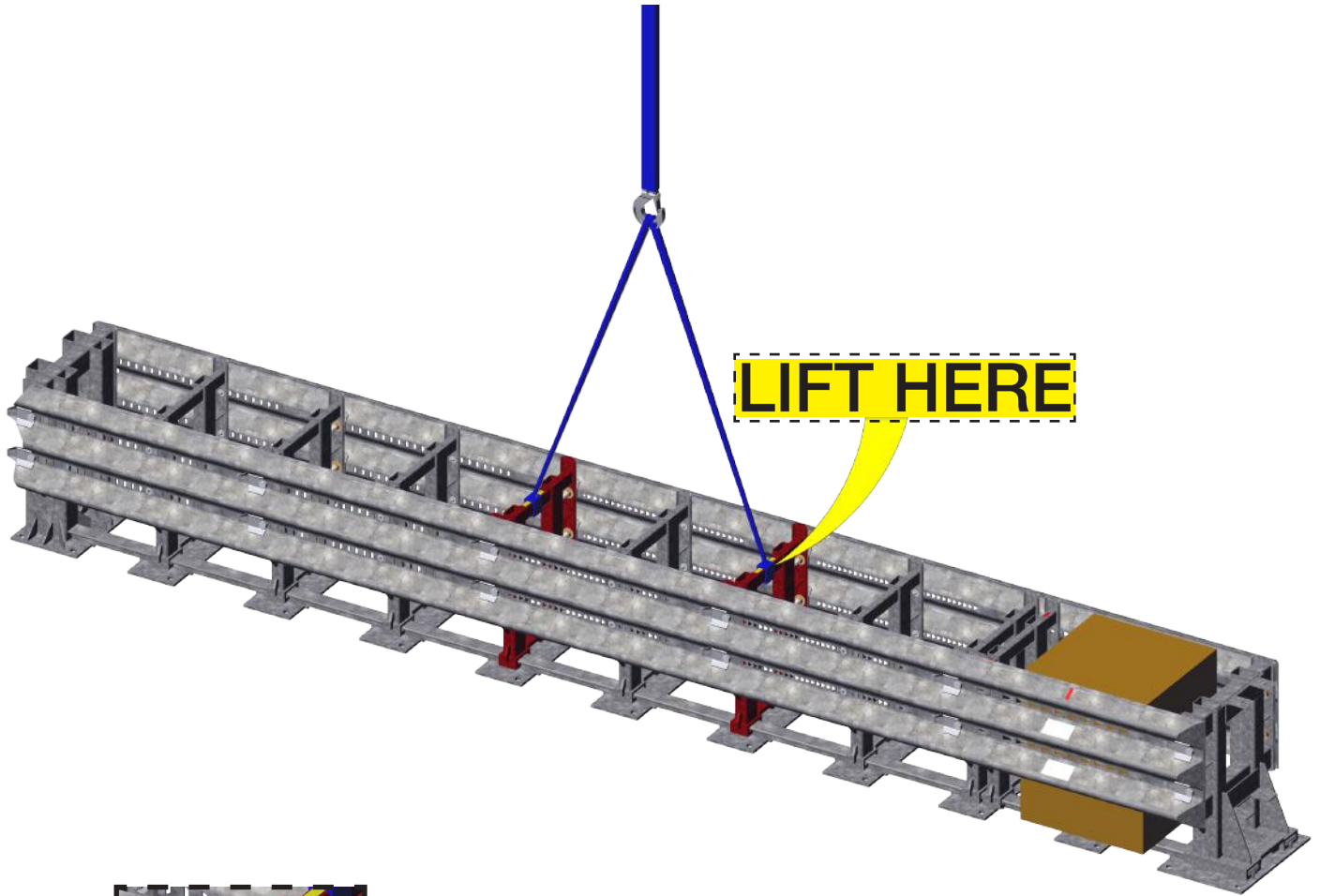

Only Lift From Diaphragms That Have A Wing Washer Assembly



NOTE: Do Not Lift from the Thrie Beam Fender Panels or Pattern Cutout

BE CAREFUL



SAFETY FIRST

System Dimensions

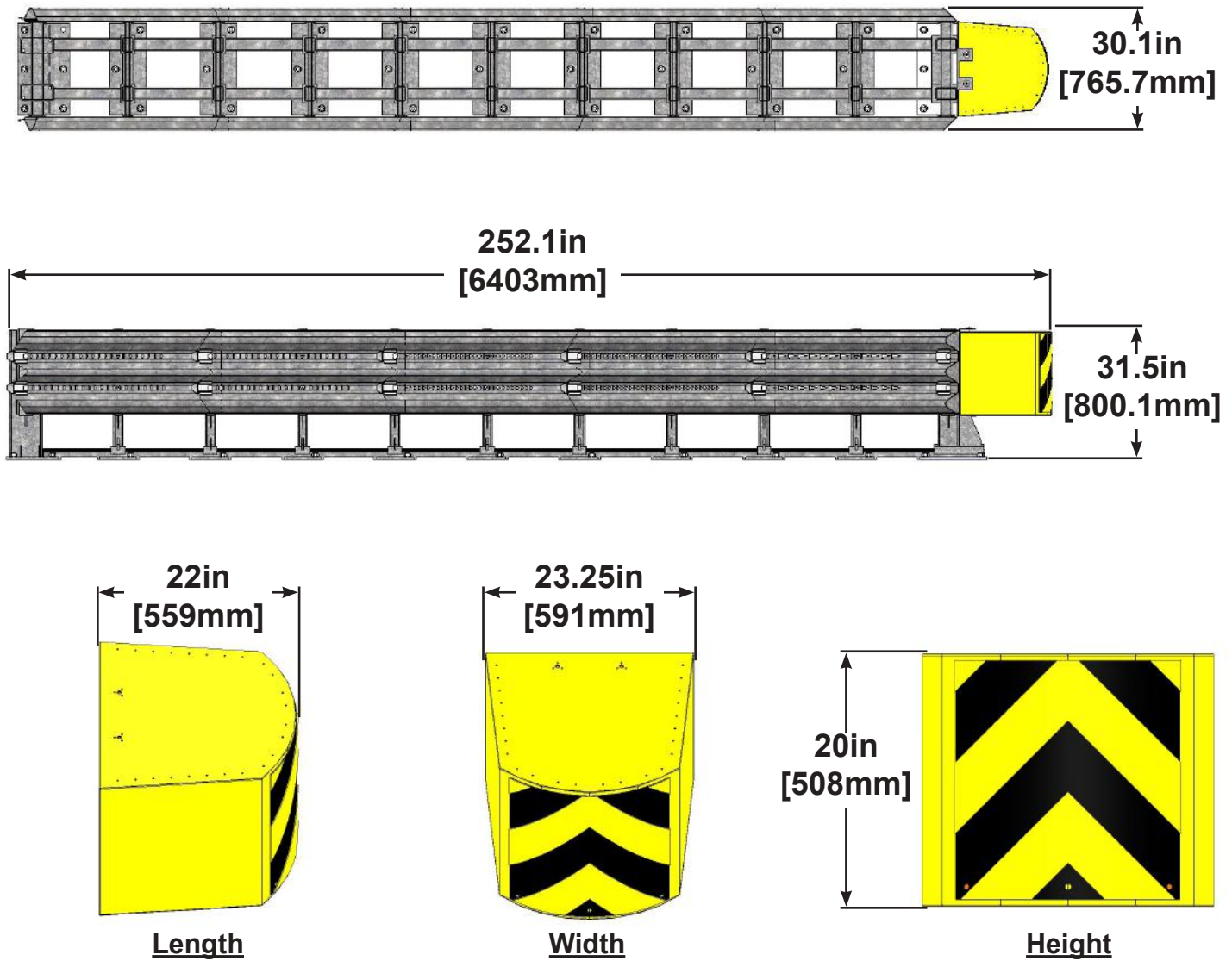

Narrow TL-3 System	Overall Dimension
Length	252.1 in [6403 mm]
Width	30.1 in [765.7 mm]
Height	31.5 in [800.1 mm]
Approximate Weight	2270 lbs [1030 kg]

Pre-Installation

Questionnaire Form

Instructions: Please fill out this document for the Delta ICC installation site. This will help to assist with the purchase of the correct items, installation preparation, and product documentation. Installation shall meet the local and federal installation standard plans. If you have any questions, contact the local road authority or deltahelp@traffixdevices.com

1. Project Contact: First Name: _____ Last Name: _____

Phone Number: _____ Email: _____

Company: _____ Position: _____

2. Location of Proposed Delta Installation: City: _____

State: _____ Highway: _____ Direction (Circle One): NB SB EB WB

Closest Exit (Exit Number and Name): _____

3. Object to be protected (Circle One): Jersey Shape K-Rail Light/Sign Post

Type 60 Guardrail/Thrie Abutment Other (Specify): _____

4. Record the GPS coordinates or nearest mile marker: _____

5. Anchoring Foundation (Circle One): Asphalt Concrete Hybrid

6. Traffic Flow Type ^(See Pg 13) **(Circle One):** Uni- Directional Bi-Directional Gore Point

7. Take several photos of the installation site showing foundation, any obstacles, object(s) being protected (including measurements), exit/highway signs, coordinates and any other images to include with this form. If any site plans or other documentation regarding this site are available, please send along with this form.

Product Placement

The Delta ICC can be used in both Bi-Directional and Uni-Directional installations. (Note, it is important to know when a transition is necessary). If there is Bi-Directional traffic flow, it is critical to protect the rear of the Delta ICC in the reverse direction with a transition.

NOTE: It is the user's responsibility to provide an adequate transition. The transition should conform to local and state government standards.

Gore Point Narrow Hazard

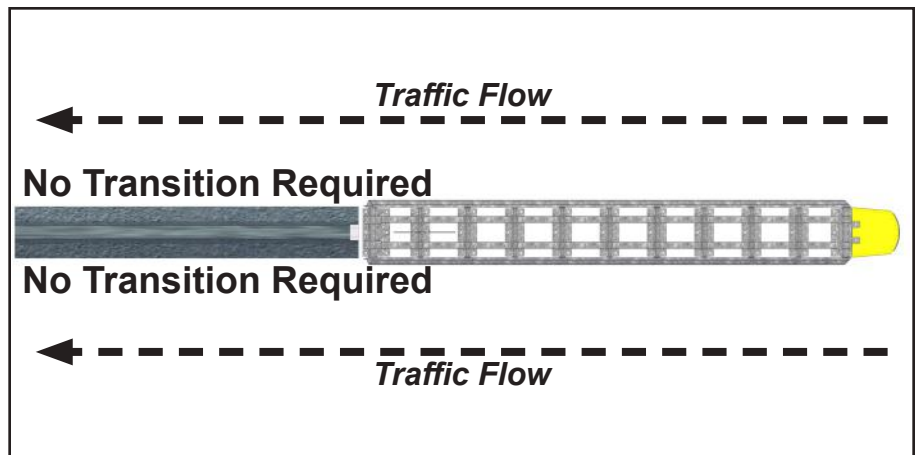

Uni-Directional Narrow Hazard

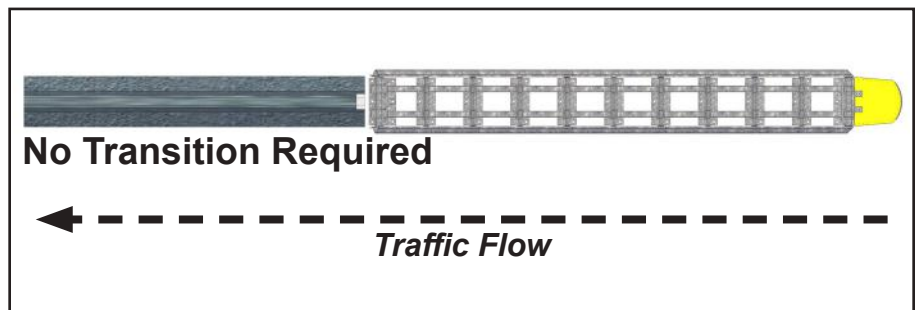

Bi-Directional Narrow Hazard

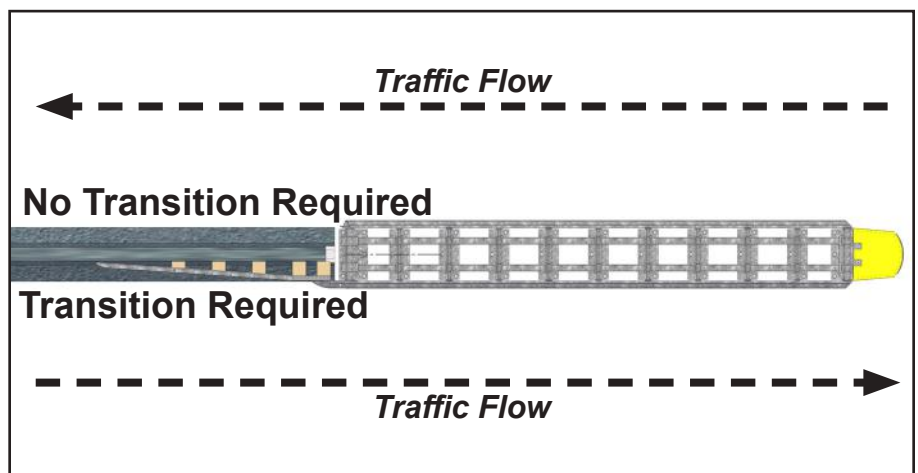

Installation Site

The Delta ICC can be installed on various foundation types including concrete, asphalt, or a hybrid of the two. The foundation and surrounding grading should comply with the recommendations in the latest version of the AASHTO Roadside Design Guide as well as local and state government specifications. Concrete foundations shall be minimum 4000 psi (28 MPa) and asphalt foundation shall have a minimum compaction of 95%. Asphalt pads may expand and contract when experiencing heat cycles. Because of this, it is important to check anchor bolt torque every 6 months to ensure they have not loosened.

Acceptable Foundations for the Delta ICC:

- 6 in. (150 mm) Reinforced Concrete
- 8 in. (203 mm) Non-Reinforced Concrete
- 6 in. (150 mm) Asphalt Over Compacted Subbase
- 3 in. (75 mm) Asphalt Over Concrete
- 8 in. (203 mm) Asphalt
- See *Appendix* (Pg 34 - 41)

Cross-Slope

The foundation must be flat with longitudinal and lateral slopes of 1V:10H or less. If the cross-slope exceeds 1V:10H, a leveling pad may be used to achieve an acceptable cross-slope.

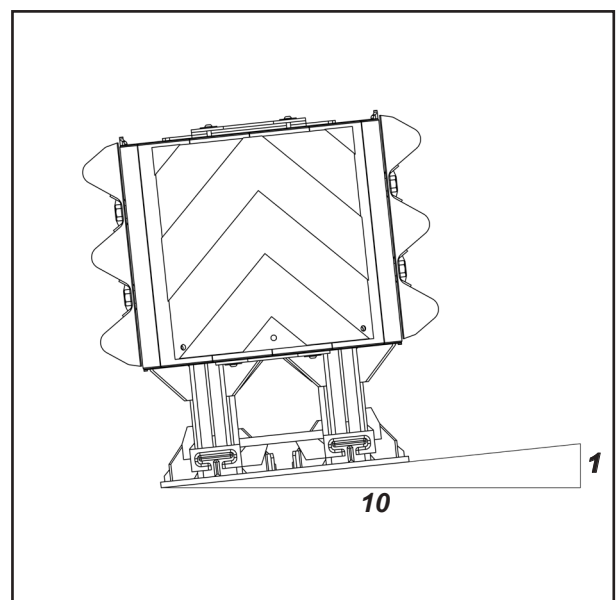
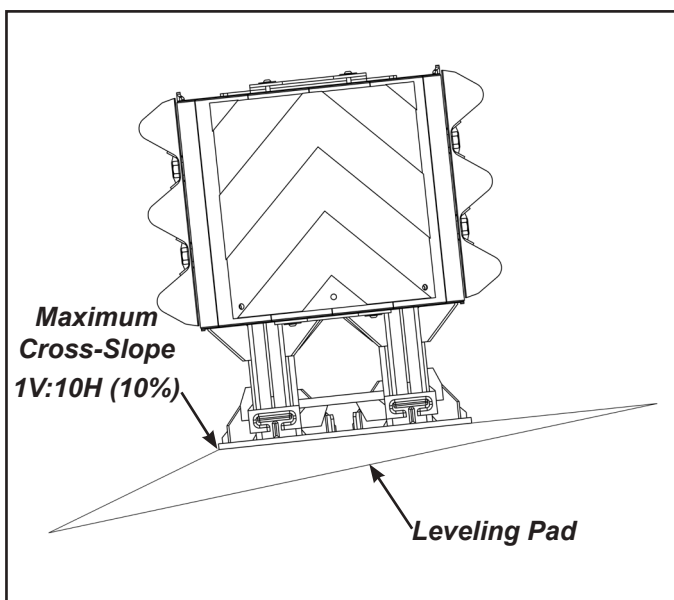

Transition Installation

To install a transition, loosen the last fender panel (Attenuation Stage 45N) towards the rear of the Delta (*If a larger transition is installed it may be necessary to loosen Attenuation Stage 3N*).

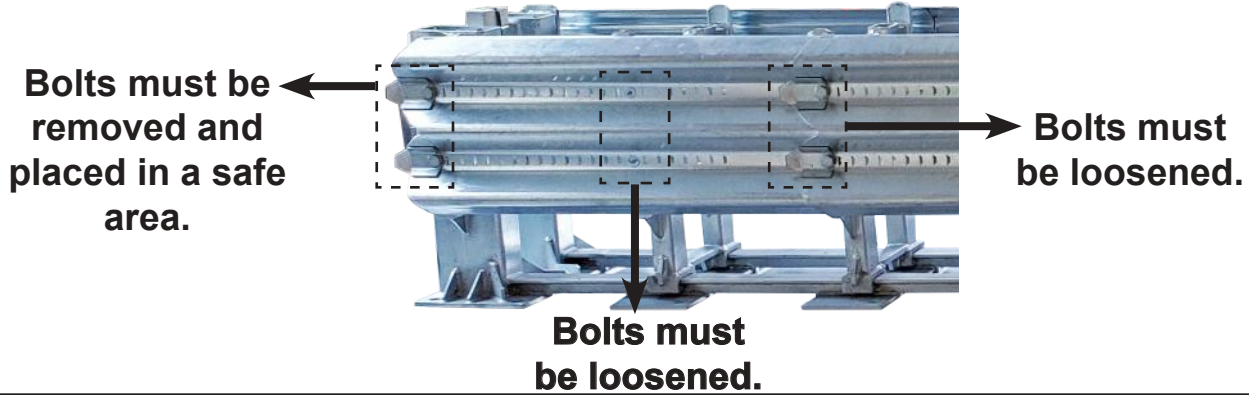

**Ratchet Wrench
1-1/16"**

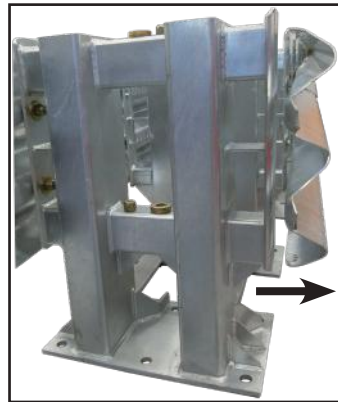

**Pull fender panel
outward**

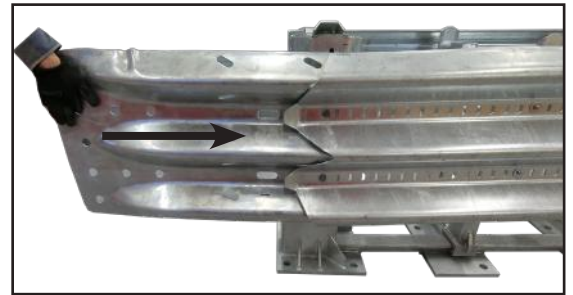

**The transition must be lapped
UNDER the last fender panel
on the Delta.**

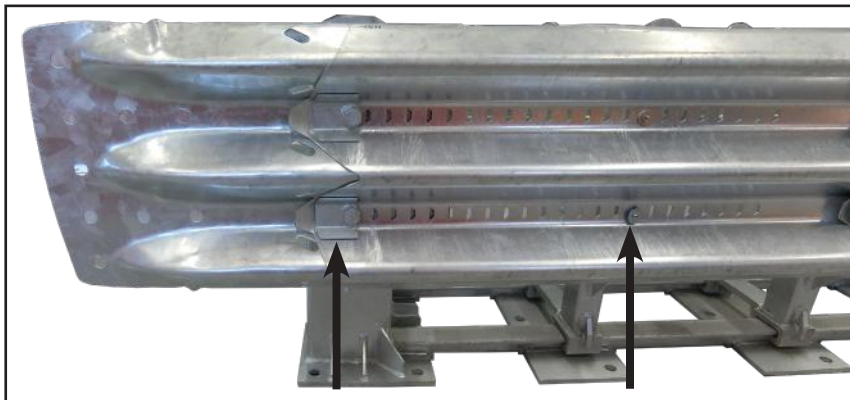

Tighten all loosened bolts. Wing washer bolt removed should be tightened to have 3-4 threads visible and one washer.

NOTE: Installing incorrectly may effect the performance of the Delta.

Transition

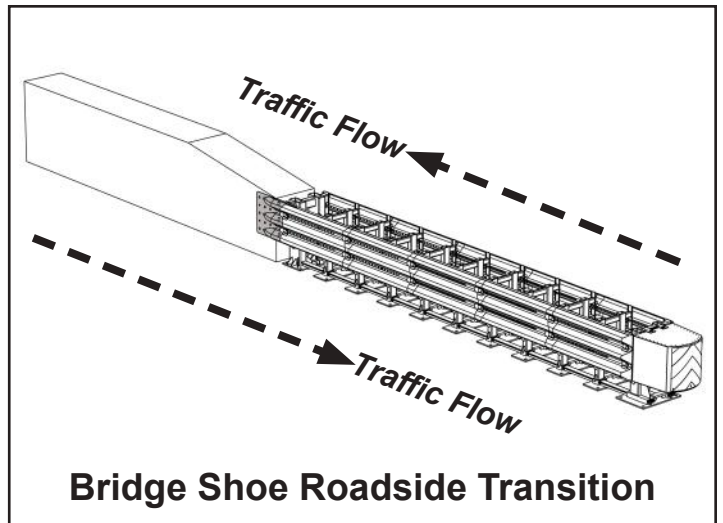
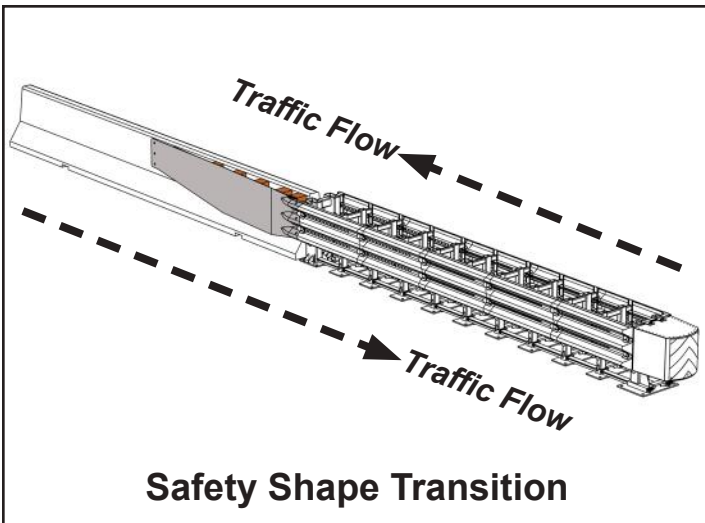
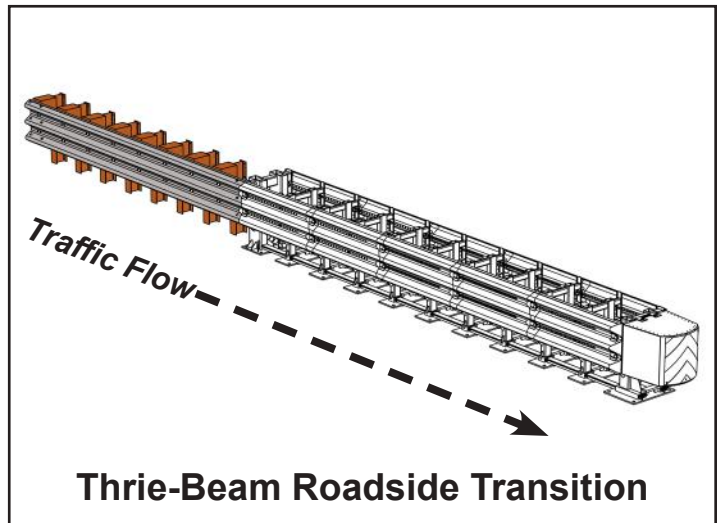
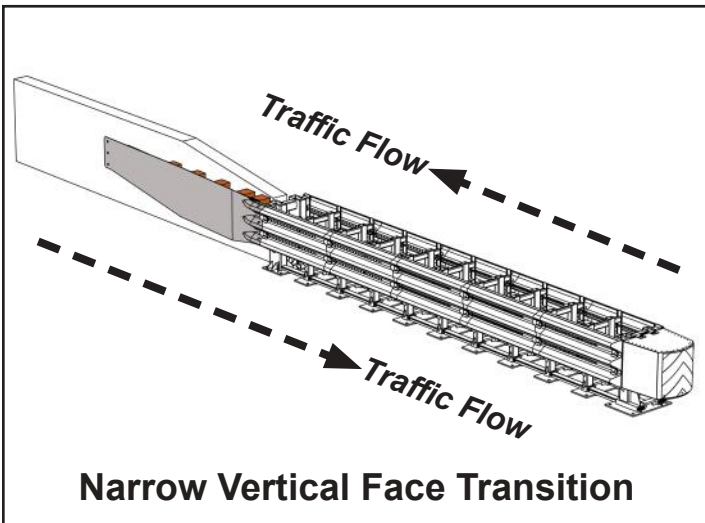
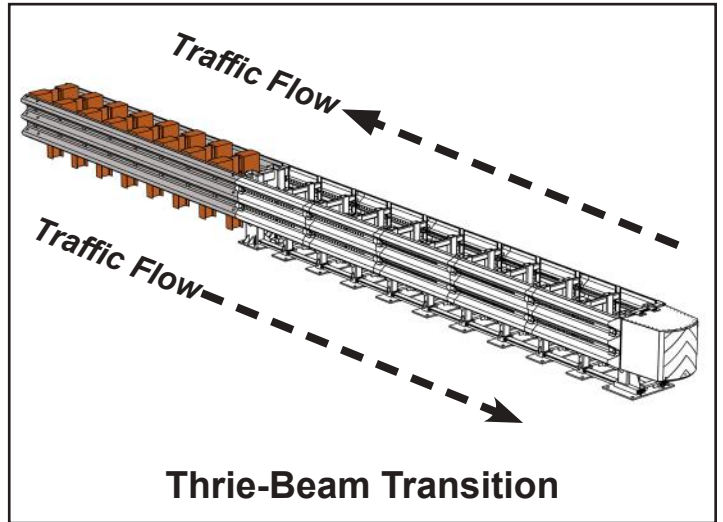
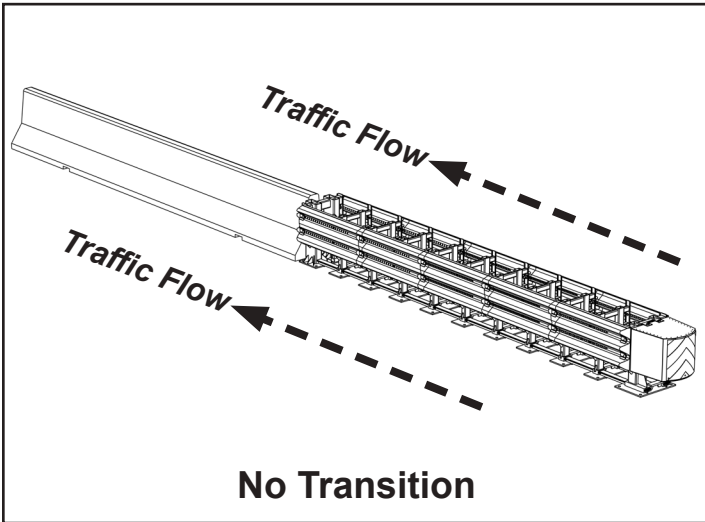

Tools Required



Lifting and moving equipment to safely lift 5000 lbs, either a fork lift, tractor or crane. Industrial Lifting Slings to safely lift 5000 lbs.



**Air Compressor
Trailer**

Air Compressor

Air Nozzle

Bottle Brush



Anti-Static Wet/Dry Vacuum



Dust Collection System

 It is the responsibility of the installer to consult OSHA silica respiratory standard 29CFR 1910.134 for debris removal from borehole(s) and use Traffix Devices approved adhesive to achieve optimum tensile strength.



NOTE: The tool list provided is a general recommendation and should not be considered an all-inclusive list. Depending on specific site conditions and complexity of the installation specified by the road authority or engineer other tools may be required. Decision as to what tools are necessary to perform the job are entirely the responsibility of the individuals or contractor conducting the installation specified by the road authority.

Tools Required



Epoxy Dispenser
Approved Epoxy:
- Hilti Hit RE 500
- Simpson SET (AT or XP)
- Red Head A7



Rotary Drill:
Bosch RH125VC or Equivalent
1" Diameter Drill Bit,
12" Long for Rotary Drill Bit for Concrete
20" Long for Rotary Drill Bit for Asphalt



Torque Wrench
with 1-7/16"
Socket



Pry Bar



Tape Measure



Chalk Reel and
Chalk



Ratchet



Socket
7/16"



Wrench
7/16"



Ratchet Wrench
1-1/16"

Additional Tools: Hand tools. Tape (to mark the drill bit).
Grinder, Hacksaw or Torch.



NOTE: The tool list provided is a general recommendation and should not be considered an all-inclusive list. Depending on specific site conditions and complexity of the installation specified by the road authority or engineer other tools may be required. Decision as to what tools are necessary to perform the job are entirely the responsibility of the individuals or contractor conducting the installation specified by the road authority.

Sentinel Activation



Serial Number:

Sentinel Serial Number:



Scan Me!
Or Visit
sentinel.traffixdevices.com/log-in



Email

Password

Log in

[Forgot password?](#)

[Don't have an account yet?](#)

[Create an account](#)

Step 1: Scan QR Code on the Sentinel, this will take you to the Log In page.

Step 2: Enter your Email and Password.

If you don't have an account, you can create an account by clicking on the Create an Account located at the bottom of the Log In page.

Step 3: Add Sentinel Serial Number.

Should you require any assistance or have questions, please visit www.traffixdevices.com/sentinel/quick-start or email sentinel support@traffixdevices.com

Installation

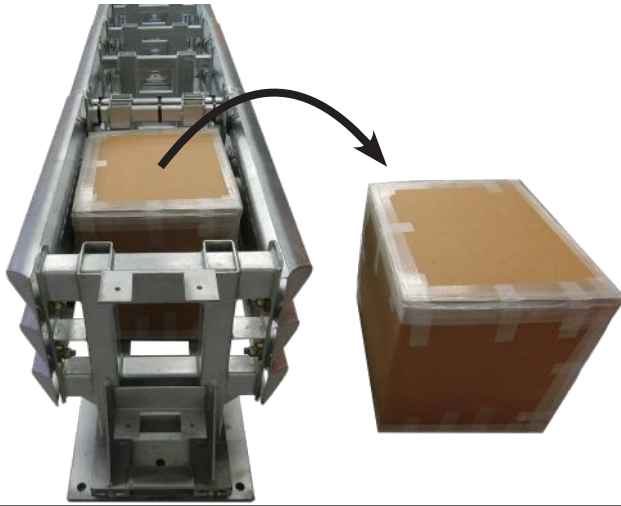

Step 1:

- Remove Box with Front Attenuation Module inside, place in safe area.

Step 2:

- Cut and Remove all Steel Bands and Zip Ties.



Step 3:

- Slide Floating Diaphragm forward.

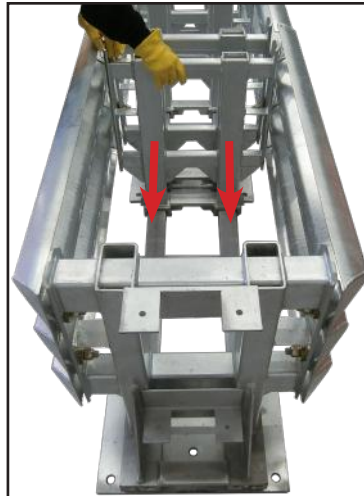

Step 4:

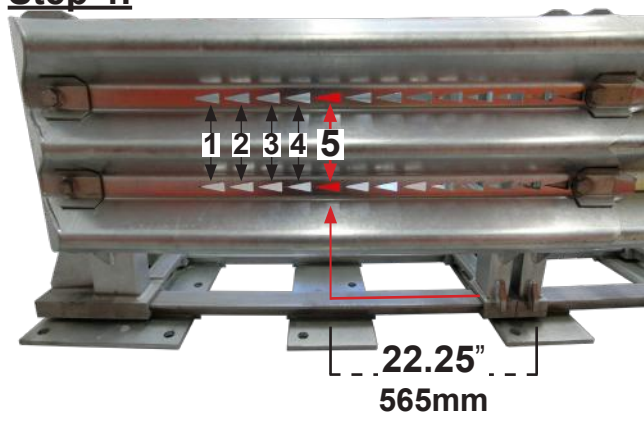

- Align Floating Diaphragm to the 5th arrow cutout from Front of the Delta.

NOTE: Diaphragm should be spaced 22.25" (565 mm) on centers.

Step 5:



- Once the Floating Diaphragm is in its proper position, secure the Diaphragm on both side with Sacrificial bolts, washers and locknuts provided.



Installation

■ Place Delta in the proper location according to the product placement section page 16. Product placement must comply with the project plans or as otherwise determined by the resident project engineer or appropriate highway authority. It is the user's responsibility to provide an adequate transition when necessary.

Step 6:

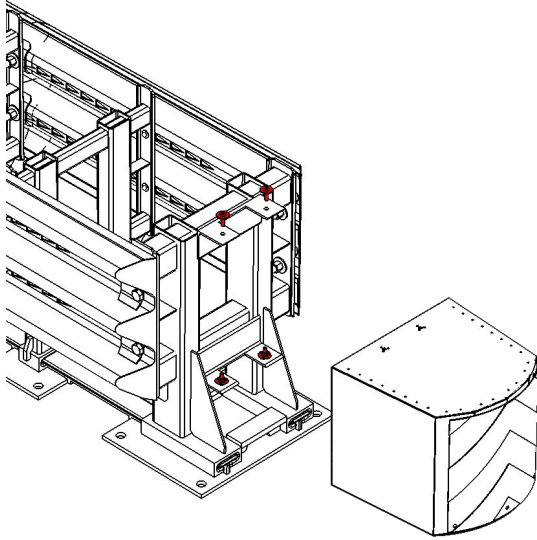

■ **Do Not Install** Front Attenuation Module, until anchor bolts have been installed. Place and keep in safe area.

Step 7:

■ The Track Assembly of the Delta is used as a drilling template. Mark Drill Bit to the proper depth using a tape marker to the length of the anchor.



<u>Pad Thickness and Material</u>	<u>Anchor Embedment</u>
6 in. (150 mm) Reinforced Concrete	5.5 in. (140 mm)
8 in. (203 mm) Non-Reinforce Concrete	5.5 in. (140 mm)
6 in. (150 mm) Asphalt Over Compacted Subbase	17 in. (430 mm)
3 in. (75 mm) Asphalt Over Concrete	17 in. (430 mm)
8 in. (200 mm) Asphalt	17 in. (430 mm)



Installation

Step 8:

- Drill one hole at the front and rear of the device. Place an anchor bolt in both of the bore holes.

Tip: This will prevent the Delta from shifting during the drilling process. This will also ensure there is sufficient room to access the rear anchor points during installation.

Back

Front

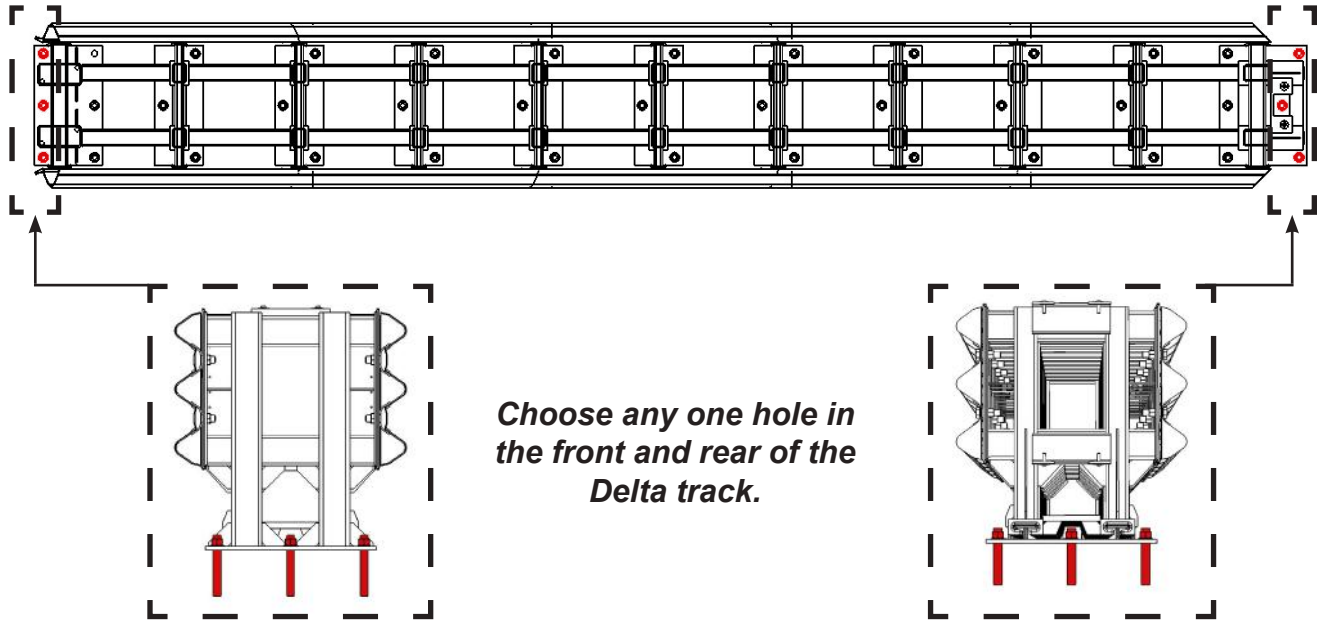

- Continue to drill the holes to the proper depth and clean during the drilling process. This can be achieved by a static free vacuum or a built in drill/dust collection system.
- To ensure holes are drilled to the proper depth check the depth once the holes have been cleared of dust.

Tip: Clean the holes as you go, this reduces cleaning time and exposure to harmful dust particles.



Installation

Step 9:

- Clean all holes with bottle brush and compressed air.

NOTE: Always follow manufacturers recommendation for cleaning and preparing bore holes for epoxy.



- Prepare anchor bolt assembly, 39 total.

NOTE: Must only use Traffix Devices approved anchor bolt.



Installation

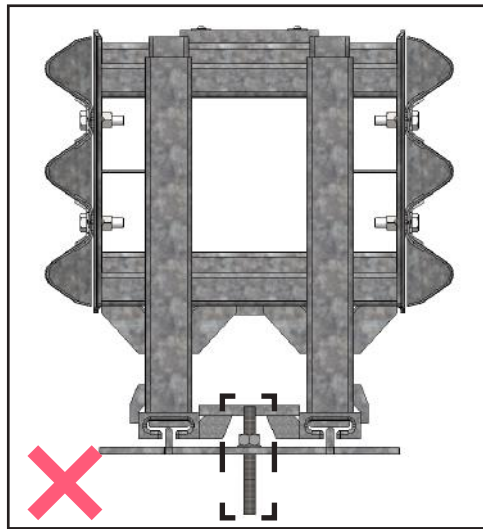
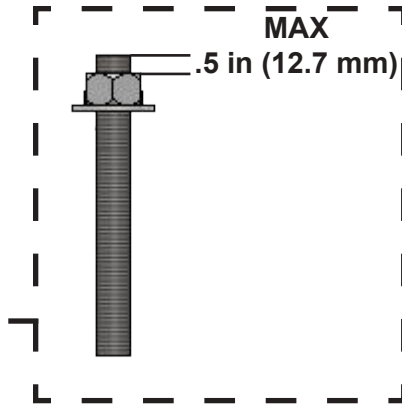
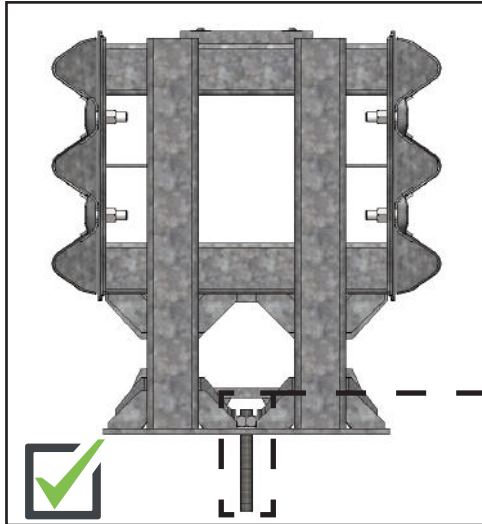

■ Anchor bolt shall not exceed .5 in (12.7 mm) past the anchor nut on all 39 anchor bolt assemblies.

NOTE: *Incorrect installation of anchor bolts may result in unsatisfactory performance and can result in serious injury.*

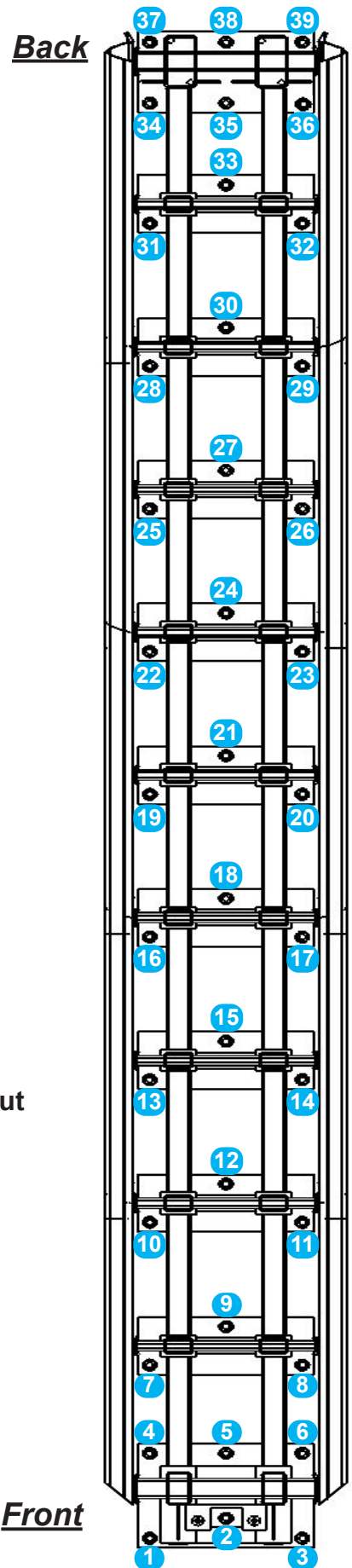

Installation

Step 10:

- Once holes are cleaned the installation is ready for epoxy. Place the epoxy nozzle close to the bottom of the hole and at an angle. Slowly pull the epoxy dispenser upward as the hole is being filled. This will ensure there is no air trapped in the hole during installation.
- Fill holes approximately 1" from the top with approved epoxy.

NOTE: Check cure time and temperature and plan anchor rod installation accordingly.



- Insert anchor rod in a twisting motion to ensure proper epoxy coverage of anchor bolt.
- Let cure according to manufactures specs.
- Torque to: Concrete anchors 100 ft-lbs (135 Nm), Asphalt anchors 10 ft-lbs (14 Nm).

NOTE: Always follow the epoxy manufactures recommendations for cleaning, inserting, and tightening anchor rods.

NOTE: Be sure to check epoxy cure time based on ambient temperature before the installation. This will ensure anchor bolts are installed properly and the epoxy doesn't cure before the anchor rods are installed.

<u>Epoxy Manufacture</u>	<u>Model</u>	<u>Approximate Needed</u>
Hilti	Hit RE 500	220 fl.Oz / 6.5 L
Simpson	SET (AT or XP)	220 fl.Oz / 6.5 L
Red Head	A7	220 fl.Oz / 6.5 L

 **NOTE:** Concrete Installation.



Installation

Step 11:



- Use a Lubricant or Grease to Prep the top and bottom holes.

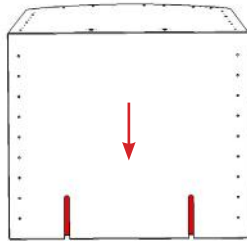
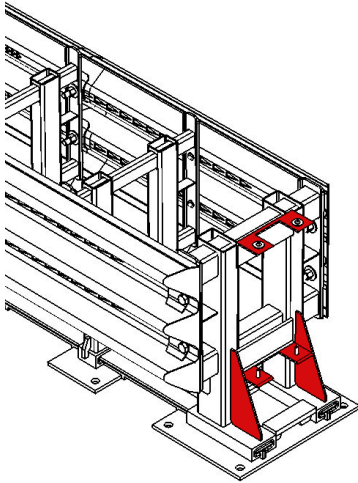

- Lift the Front Attenuation Module into position, back openings shall align with Impact Head Diaphragm.

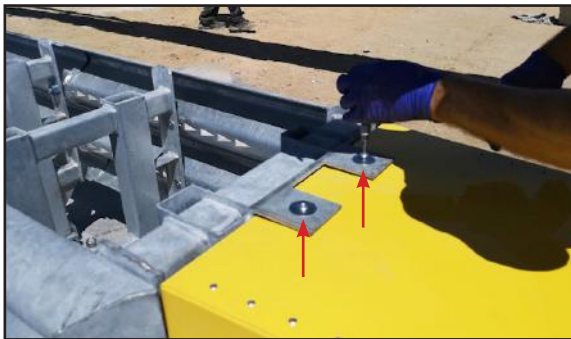

- Once the Front Attenuation Module is in its proper position, secure the module both top and bottom with bolts and washers. Tighten to a minimum of 20 ft-lbs (27 Nm).



Installing Nose Sheeting

Step 12:

Object Marker is Reversible

Unbolt and Flip Over
to Change Pattern

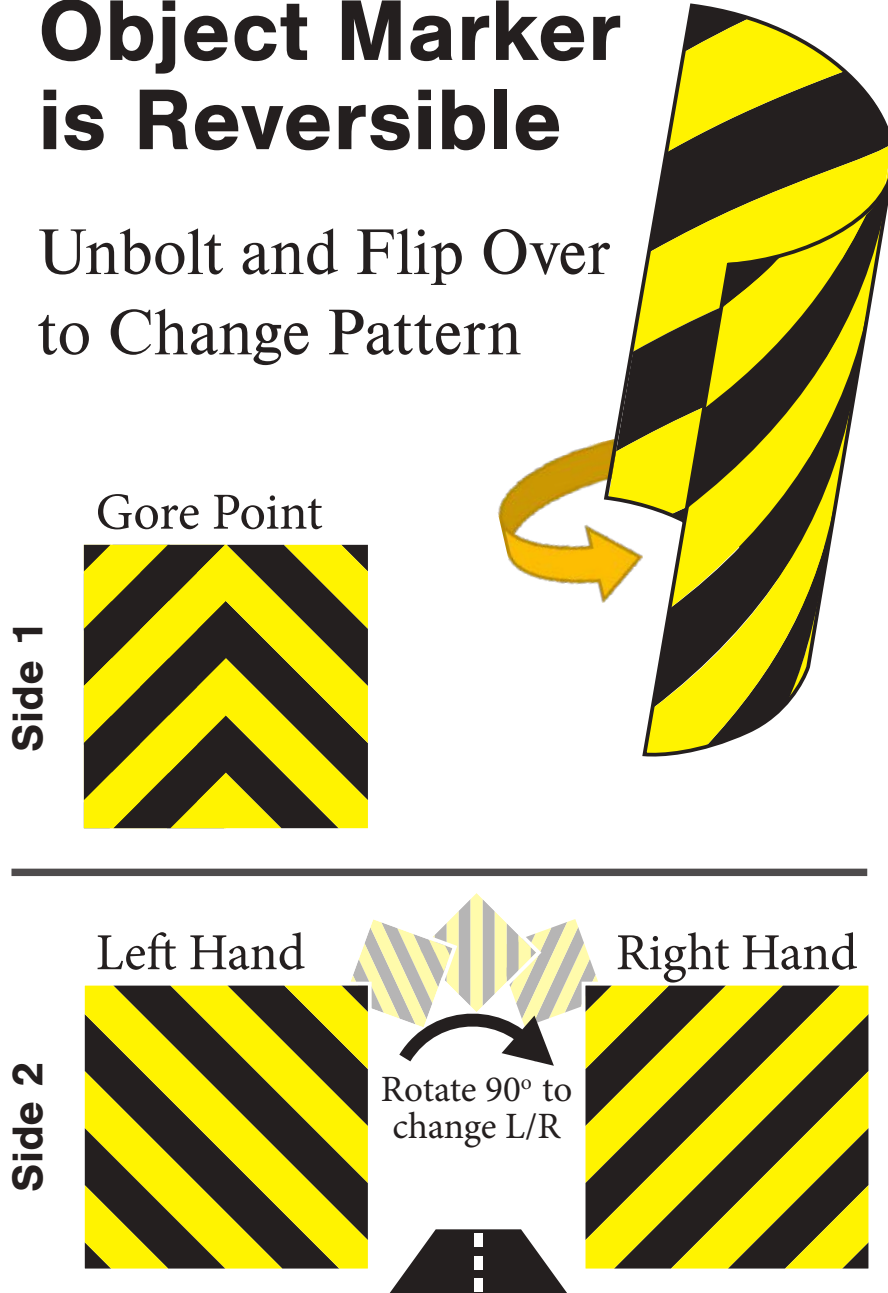

The nose sheeting has been provided as a way to easily customize field use. The diagonal stripes used on the Left Hand Traffic Flow can be rotated 90 degrees for Right Hand Traffic Flow. Turn the sheeting over and it is used for Gore Point Traffic Flow. To determine the correct nose sheeting side follow state regulations and installation location. Once the direction is determined, secure the sheeting to the front attenuation module with supplied screws using a 7/16" socket.

Serial Number

Date of Installation: _____

Location: _____

Condition of Delta: _____



TrafFix Devices Inc.
SN **DXXXXX**
Serialized Component

**Front Attenuation Module
Serial Number:**



TrafFix Devices Inc.
160 Avenida La Pata
San Clemente, CA 92673
www.traffixdevices.com
PHONE: 949-361-5663
PAT. PENDING

JAN	FEB	MAR	APR	2021
MAY	JUN	JUL	AUG	2022
SEP	OCT	NOV	DEC	2023
				2024
				2025

DELTA REDIRECTIVE CRASH CUSHION
MODEL 75000
THIS ATTENUATOR CONFORMS TO MASH TEST STANDARD
REFER TO OWNERS MANUAL FOR LIFTING INSTRUCTIONS

Made in USA ID No. **XXXXX**

Track Serial Number:



www.traffixdevices.com
(949) 361-5663

**Sentinel™
IMPACT TRACKER**

This device complies with Part 15 of the FCC Rules and Industry Canada's license exempt RSS standards. Operation is subject to the following two conditions: (1) this device may not cause interference, and (2) this device must accept any interference, including that which may cause undesired operation of the device.

Contains FCC ID: [redacted] Contains IC: [redacted] **Serial Number:** [redacted]

Sentinel Serial Number:



Inspection Checklist

<u>Items to Inspect</u>	✓
39 Anchor Bolts are Installed	
39 Anchor Bolts Do Not Exceed .5 in (13 mm) Past Anchor Nut	
39 Anchor Bolts are Properly Torqued. Concrete Installations 100 ft- lbs (135 Nm). Asphalt Installations 10 ft-lbs (14 Nm)	
All Diaphragms are Spaced 22.25" ± 1" If Spacing Falls out of Spec the Diaphragms with the Sacrificial Hardware shall be Adjusted.	
Rear Fender Panels can Telescope Rearward 35" (889 mm) without Obstruction	
All Wing Washers are the Correct Orientation	
Check all Factory Hardware	
Front Attenuation Module is Installed with 4 Fasteners	
Front Attenuation Module has Proper Sheeting for the Site	
All Tools and Debris are Cleared from Delta	
Serial Numbers have been Documented	

Inspected By: _____

Contact Information: _____ Date: _____

Maintenance

The Delta ICC is a low-maintenance unit. Regular inspections depend on site conditions, traffic volume and weather conditions. Regular inspections of the Delta ICC is recommended and shall be made by local highway authority, always follow local guidelines for frequency of inspections to ensure adequate repairs are made to the unit.

Maintenance includes but not limited to the following:

- Clear and dispose of on site debris (remove excessive dirt, vegetation, snow, etc)
- Check for damage to the front attenuation module
- Check bolts are tight and rust free
- Check for loosened, damaged or rusted anchor bolts
- If installed on asphalt the anchor bolts should be checked on a routine basis
- Check for missing components and vandalism
- Check to see if there is evidence of an impact. Damage to the cutout patterns in the fender panels should be documented and replaced.



To determine if a Delta needs replacement or is potentially reusable, an engineer experienced in highway products/safety directed by local highway authority must be consulted.

Notes: _____

Inspected By: _____

Date: _____

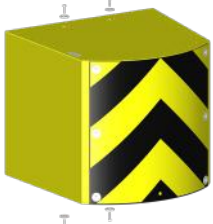
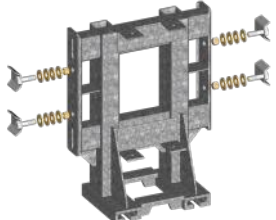
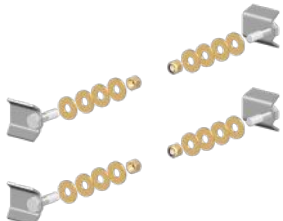
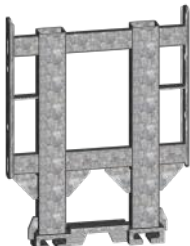
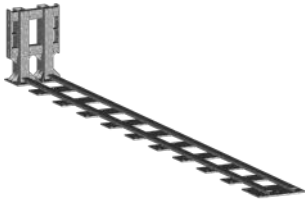
Delta Replacement Parts

<u>Part No.</u>	<u>Description</u>	
75220-N-Y4	Front Attenuation Module Kit with Hardware, 4 Bolts (1/4"-20 x 1"), 4 Washers (1/4") and Object Marker with Hardware, 6 Bolts (1/4"-20 x 1") and 6 Washers (1/4")	
75230-N-KIT	Front Impact Diaphragm Kit, 1 Front Impact Head Diaphragm, 4 Wing Washers, 4 Nuts (3/4"-10) and 16 Washers (3/4")	
75230-HW-KIT	Front Impact Head Diaphragm Hardware Kit, 4 Wing Washers, 4 Nuts (3/4"-10) and 16 Washers (3/4")	
75240-N	Steel Diaphragm (9 per system)	
75250-TL3-N	Track Weldment	
75208-CA	Concrete Anchor Rod Assembly, 1 Anchor Rod (7/8"-9 x 8"), 1 Nut (7/8"-9) and 1 Washers (7/8") (39 per system)	
75218-AA	Asphalt Anchor Rod Assembly, 1 Anchor Rod (7/8"-9 x 18"), 1 Nut (7/8"-9) and 1 Washers (7/8") (39 per system)	

Part No.

Description

75260-TL3-1N-KIT

Fender Panel 1N, Kit with Hardware,
2 Wing Washers, 2 Lock Nuts (3/4"-10), 2 Washers (3/4"),
2 Sacrificial Bolts (1/4"-20 x 1-1/2"), 2 Lock Nuts (1/4"-20) and
4 Washers (1/4") (2 per system)

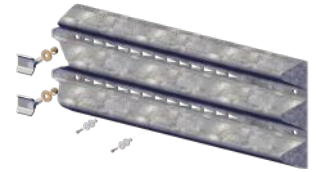

75260-TL3-2N-KIT

Fender Panel 2N, Kit with Hardware,
2 Wing Washers, 2 Lock Nuts (3/4"-10), 2 Washers (3/4"),
2 Sacrificial Bolts (1/4"-20 x 1-1/2"), 2 Lock Nuts (1/4"-20) and
4 Washers (1/4") (2 per system)

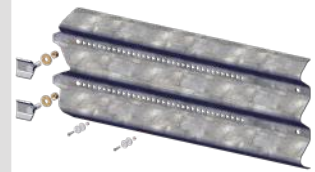

75260-TL3-3N-KIT

Fender Panel 3N, Kit with Hardware,
2 Wing Washers, 2 Lock Nuts (3/4"-10), 2 Washers (3/4"),
2 Sacrificial Bolts (1/4"-20 x 1-1/2"), 2 Lock Nuts (1/4"-20) and
4 Washers (1/4") (2 per system)

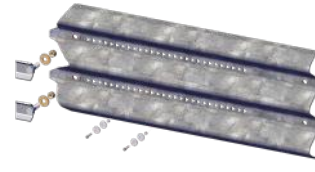

75260-TL3-45N-KIT

Fender Panel 45N, Kit with Hardware,
2 Wing Washers, 2 Lock Nuts (3/4"-10), 2 Washers (3/4"),
2 Sacrificial Bolts (1/4"-20 x 1-1/2"), 2 Lock Nuts (1/4"-20) and
4 Washers (1/4") (2 per system)

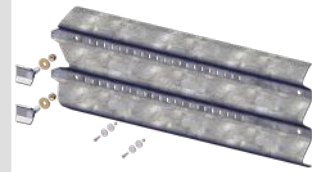

75260-TL3-45N

Fender Panel 45N

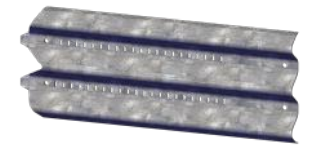

75240-HW-KIT

Floating Diaphragm Hardware Kit,
4 Bolts (1/4"-20 x 1-1/2"),
4 Nuts (1/4"-20) and 8 Washers (1/4") (5 kits per system)





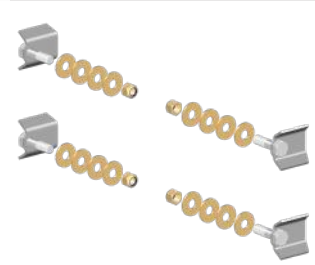

75250-HW-KIT

Rear Track Backup Weldment Hardware Kit,
4 Wing Washers, 4 Nuts (3/4"-10) and 16 Washers (3/4")

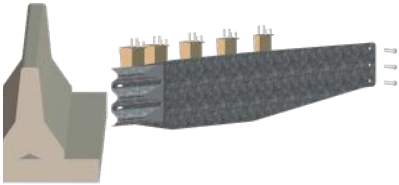

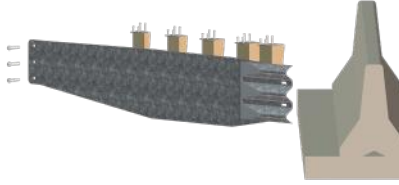
Delta Transition Replacement Parts

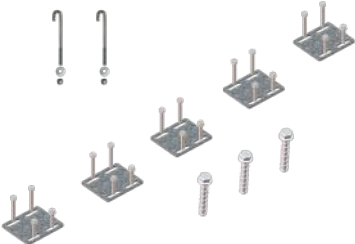
<u>Part No.</u>	<u>Description</u>	
75270-RH-KIT	Right Transition Weldment Kit with Hardware, 3 Anchor Bolts (3/4"), 5 Blockout Holders, 10 Wooden Lag Bolts (3/8"), 10 Self-Tapping Screw (3/8"), 2 J-Bolt (8") and 2 Nylock Nuts (1/2"-13)	
	 <i>Wood Blocks NOT Included. Barrier NOT Included.</i>	
75270-RH	Right Transition Weldment	
75270-LH-KIT	Left Transition Weldment Kit with Hardware, 3 Anchor Bolts (3/4"), 5 Blockout Holders, 10 Wooden Lag Bolts (3/8"), 10 Self-Tapping Screw (3/8"), 2 J-Bolt (8") and 2 Nylock Nuts (1/2"-13)	
	 <i>Wood Blocks NOT Included. Barrier NOT Included.</i>	
75270-LH	Left Transition Weldment	
75270-HW-KIT	Transition Hardware, 3 Anchor Bolts (3/4"), 5 Blockout Holders, 10 Wooden Lag Bolts (3/8"), 10 Self-Tapping Screw (3/8"), 2 J-Bolt (8") and 2 Nylock Nuts (1/2"-13)	



NOTE: Wood Blocks NOT Included. Barrier NOT Included.

Item No.	Length	QTY.
1	43 in. (1092 mm)	13
2	246 in. (6248 mm)	4

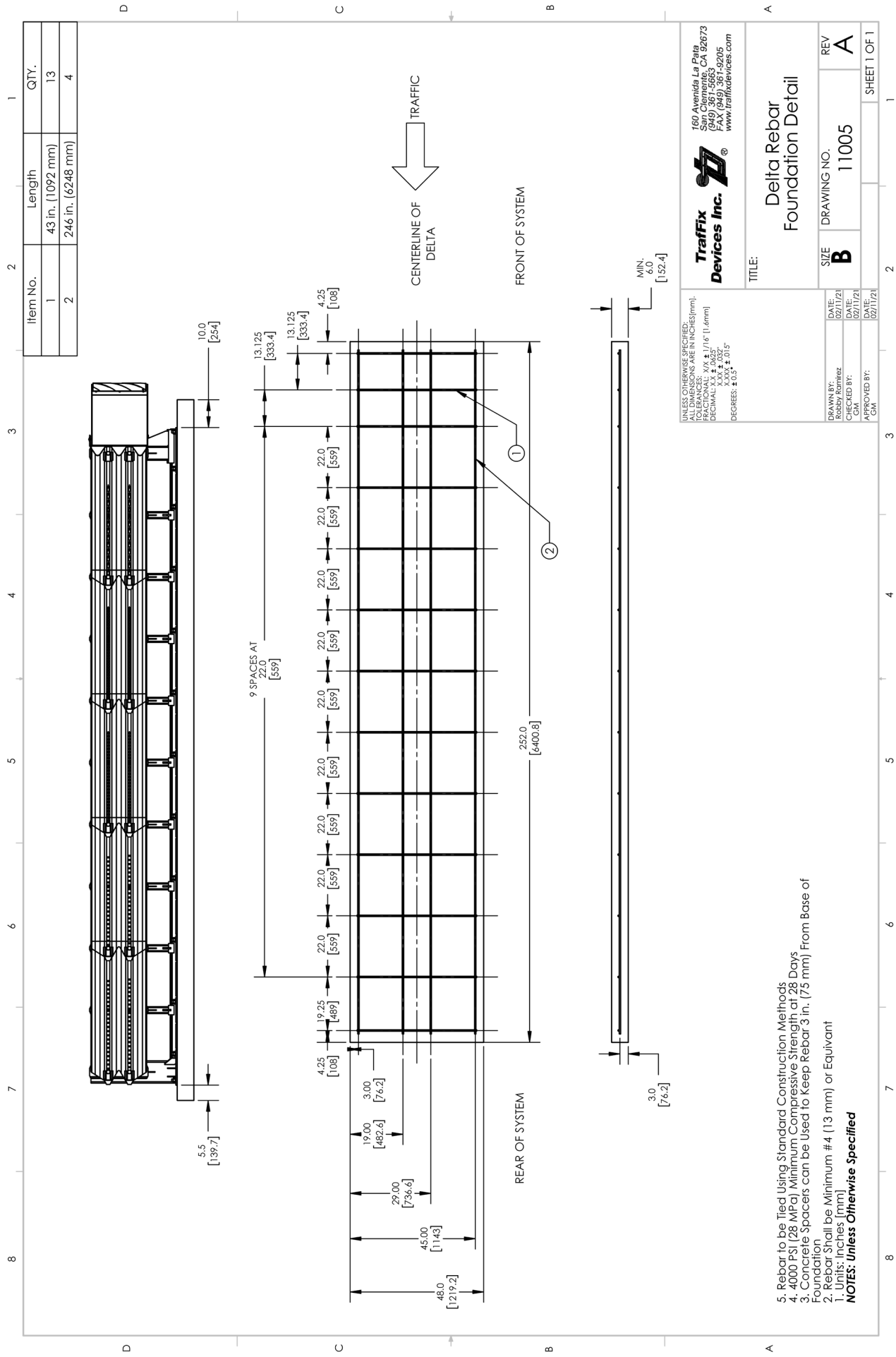

Traffix Devices Inc.
 160 Avenida La Palms
 San Clemente, CA 92673
 (949) 361-9205
 FAX (949) 361-9205
 www.traffixdevices.com

UNLESS OTHERWISE SPECIFIED:
 ALL DIMENSIONS ARE IN INCHES (mm).
 FRACTIONAL: X/Y & 1/16 (1.6mm)
 DECIMAL: .XXX & .032
 DEGREES: ° XXX' ± .015

TITLE: Delta Rebar Foundation Detail

SIZE: B DRAWING NO.: 11005

REV: A

DATE: 02/11/21
 DRAWN BY: Robby Romerez
 CHECKED BY: CMK
 APPROVED BY: GM

DATE: 02/11/21

SHEET 1 OF 1

5. Rebar to be Tied Using Standard Construction Methods
 4. 4000 PSI (28 MPa) Minimum Compressive Strength at 28 Days
 3. Concrete Spacers can be Used to Keep Rebar 3 in. (75 mm) From Base of Foundation
 2. Rebar Shall be Minimum #4 (13 mm) or Equivalent
 1. Units: Inches (mm)
NOTES: Unless Otherwise Specified

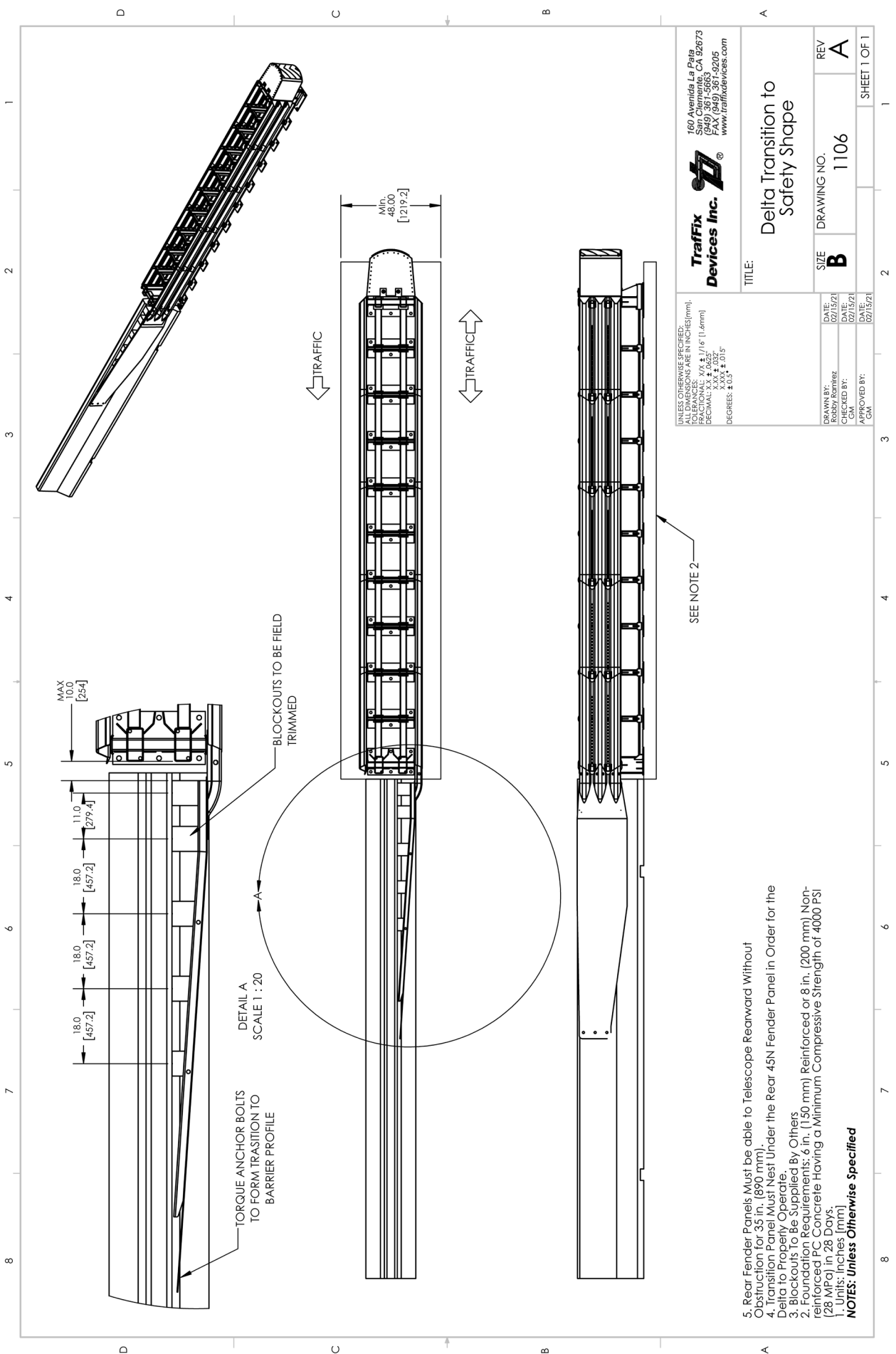

UNLESS OTHERWISE SPECIFIED:
DIMENSIONS ARE IN INCHES (mm).
TOLERANCES: ± 0.031 (1.3 mm)
SPECIFICATIONS: A 762.5 (1 1/4) (1.6 mm)
STRENGTH: 3000 ± 0.037
DEGREES: ± 0.015

TrafFix Devices Inc.
160 Avenida La Plata
San Jose, CA 95128
(949) 361-5663
(949) 361-9205
www.traffixdevices.com

TITLE: Delta Transition to Safety Shape

REV	A
DRAWING NO.	1106
SIZE	B
DATE:	02/15/21
CHECKED BY:	JMM
DATE:	02/15/21
APPROVED BY:	JMM
DATE:	02/15/21

SHEET 1 OF 1

5. Rear Fender Panels must be able to Telescope Rearward Without Obstruction for 35 in. (890 mm).
 4. Transition Panel Must Nest Under the Rear 45N Fender Panel in Order for the Delta to Properly Operate.
 3. Blockouts To Be Supplied By Others
 2. Foundation Requirements: 6 in. (150 mm) Reinforced or 8 in. (200 mm) Non-reinforced PC Concrete Having a Minimum Compressive Strength of 4000 PSI (28 MPa) in 28 Days.
 1. Units: Inches [mm]
- NOTES: Unless Otherwise Specified**

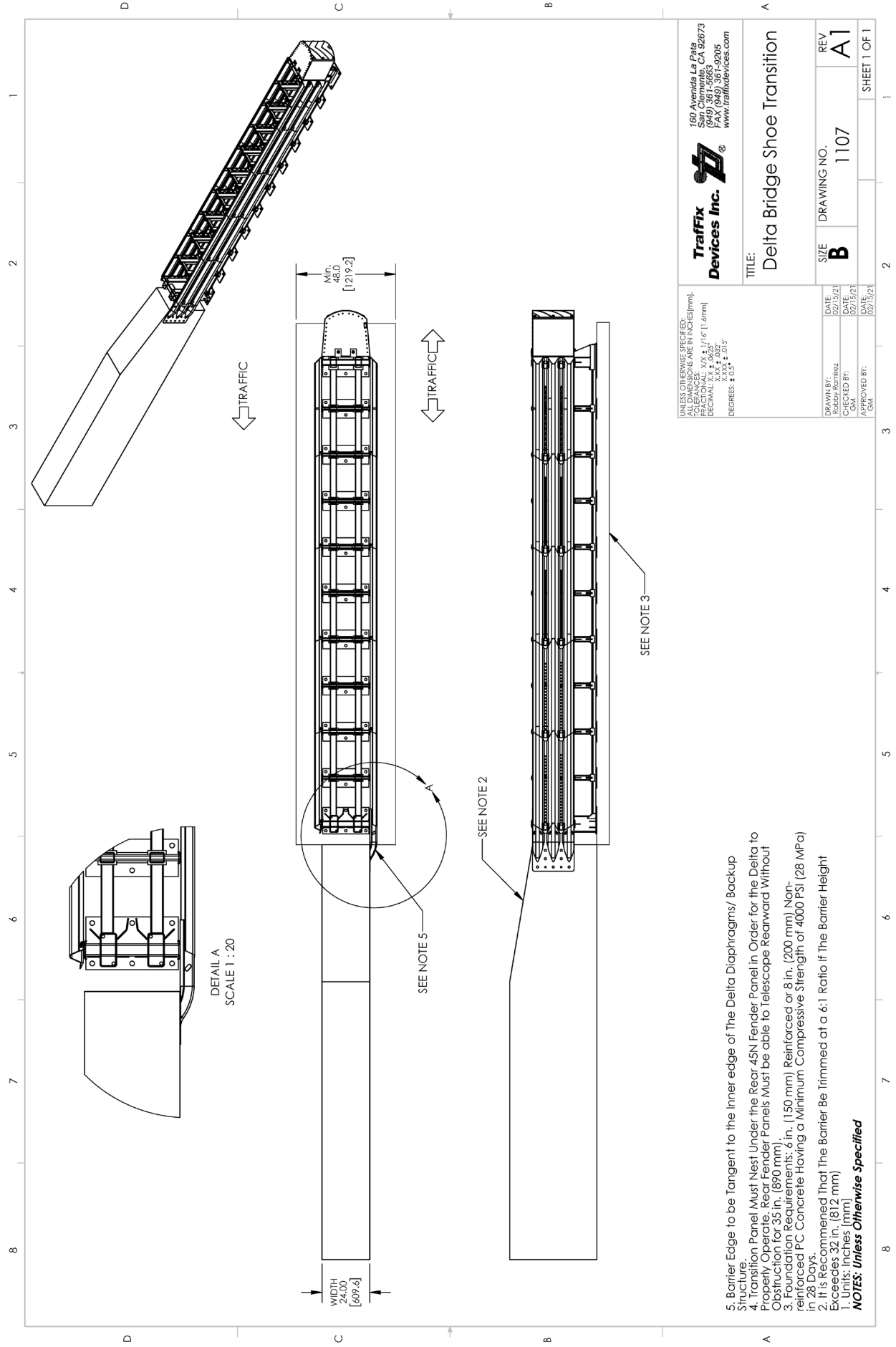

TraFFix Devices Inc.
 160 Avenida La Plata
 San Clemente, CA 92673
 (949) 361-5663
 FAX (949) 361-9205
 www.traffixdevices.com

TRAFFIX DEVICES SPECIFICATIONS
 ALL DIMENSIONS ARE IN INCHES (mm).
 TOLERANCES: 1/8" ± 1/16" (1.6mm)
 DECIMALS: 0.05"
 FRACTIONS: XXXX/1000"
 DECIMALS: ± 0.01"
 FRACTIONS: ± 0.01"

TITLE: Delta Bridge Shoe Transition

DATE: 02/15/21	SIZE: B	DRAWING NO.: 1107	REV: A1
DRAWN BY: Robby Ramirez			
CHECKED BY: JCM			
APPROVED BY: JCM			SHEET 1 OF 1

- Barrier Edge to be Tangent to the Inner edge of The Delta Diaphragms/ Backup Structure.
 - Transition Panel Must Nest Under the Rear 45N Fender Panel in Order for the Delta to Properly Operate. Rear Fender Panels Must be able to Telescope Rearward Without Obstruction for 35 in. (890 mm).
 - Foundation Requirements: 6 in. (150 mm) Reinforced or 8 in. (200 mm) Non-reinforced PC Concrete Having a Minimum Compressive Strength of 4000 PSI (28 MPa) in 28 Days.
 - If is Recommended That The Barrier Be Tipped at a 6:1 Ratio if The Barrier Height Exceeds 32 in. (812 mm)
1. Units: inches [mm]
NOTES: Unless Otherwise Specified

1 2 3 4 5 6 7 8

D C B A

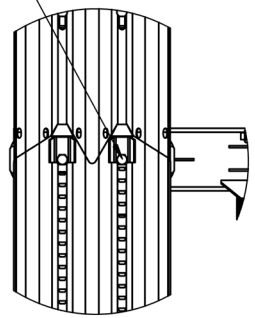
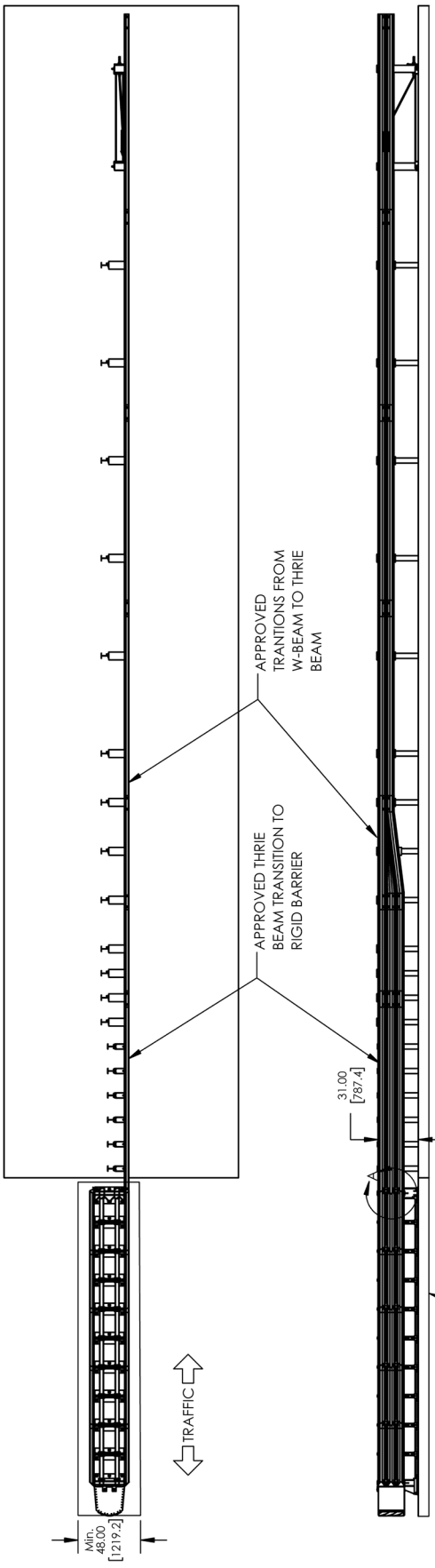

5. Gaurdtrail, Posts, Blockouts, and Related Hardware to be Supplied by Others.
 4. Bent Washer Assemblies are Used to Fasten Thrie Beam Panels to the Delta Foundation Requirements; 6 in. (150 mm) Reinforced or 8 in. (200 mm) Non-reinforced PC Concrete Having a Minimum Compressive Strength of 4000 PSI (28 MPa) in 28 Days.
 2. Thrie Beam Transition Must Nest Under the Rear 45N Fender Panel in Order for the Delta to Properly Operate. The 45N Fender Panels Must be able to Telescope Rearward Without Obstruction for 35 in. (890 mm).
1. Units: Inches [mm]
NOTES: Unless Otherwise Specified

UNLESS OTHERWISE SPECIFIED:
 DIMENSIONS ARE IN INCHES (mm).
 FRACTIONAL: X/X, 1/16 (1.6mm)
 DECIMAL: X.XX, .032
 ANGLES: X.X, ±.015
 DEGREE: ±.01

Traffix Devices Inc.
 160 Avenida La Plata
 San Clemente, CA 92673
 (949) 381-1109
 FAX (949) 381-9205
 www.traffixdevices.com

TITLE: **Delta Transition to W-Beam**

DATE: 02/16/21	REV
DRAWN BY: Robby Rogniez	A
CHECKED BY: GM	DRAWING NO. 1109
DATE: 02/16/21	SIZE B
APPROVED BY: GM	SHEET 1 OF 1

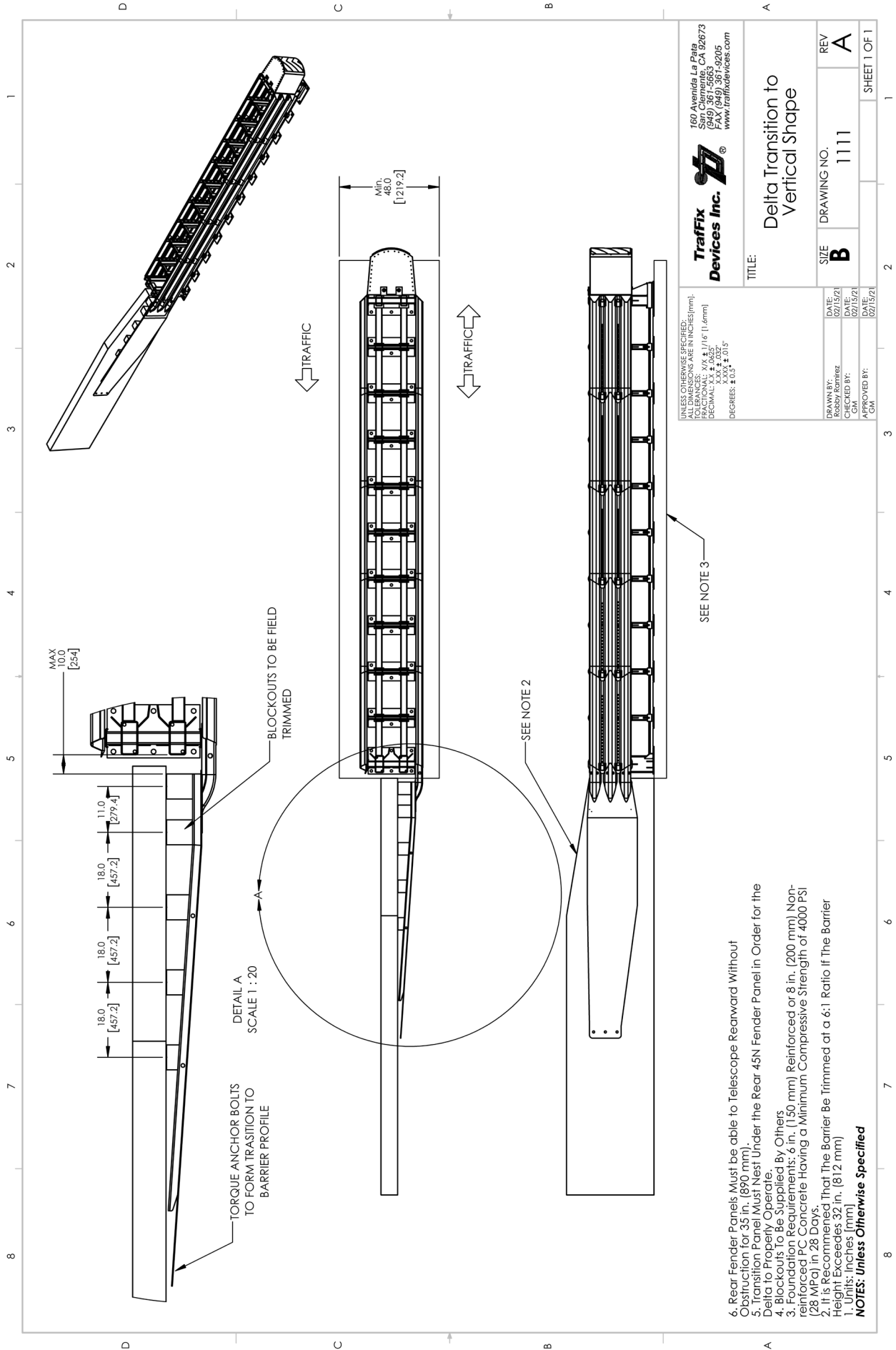

Traffix Devices Inc.
 160 Avenida La Plata
 San Clemente, CA 92673
 (949) 361-9205
 FAX (949) 361-9205
 www.traffixdevices.com

TITLE: Delta Transition to Vertical Shape

SIZE: **B** DRAWING NO.: 1111 REV: **A**

UNLESS OTHERWISE SPECIFIED:
 ALL DIMENSIONS ARE IN INCHES (mm).
 FRACTIONAL: X/8 & 1/16" (1.4mm)
 DECIMAL: .1, .2, .3, .4, .5, .6, .7, .8, .9
 ANGLES: X.XX & .032°
 X.XXX & .015°
 DEGREES: ± 0.3°

DRAWN BY: Robby Ramirez	DATE: 02/15/21
CHECKED BY: G.M.	DATE: 02/15/21
APPROVED BY: G.M.	DATE: 02/15/21

6. Rear Fender Panels Must be able to Telescope Rearward Without Obstruction for 33 in. (840 mm).
 5. Transition Panel Must Nest Under the Rear 45N Fender Panel in Order for the Delta to Properly Operate.
 4. Blockouts to be Supplied by Others.
 3. Foundation Requirements: 6 in. (150 mm) Reinforced or 8 in. (200 mm) Non-reinforced PC Concrete Having a Minimum Compressive Strength of 4000 PSI (28 MPa) in 28 Days.
 2. It is Recommended That The Barrier Be Trimmed at a 6:1 Ratio If The Barrier Height Exceeds 32 in. (812 mm)
- NOTES: Unless Otherwise Specified**
 1. Units: Inches (mm)

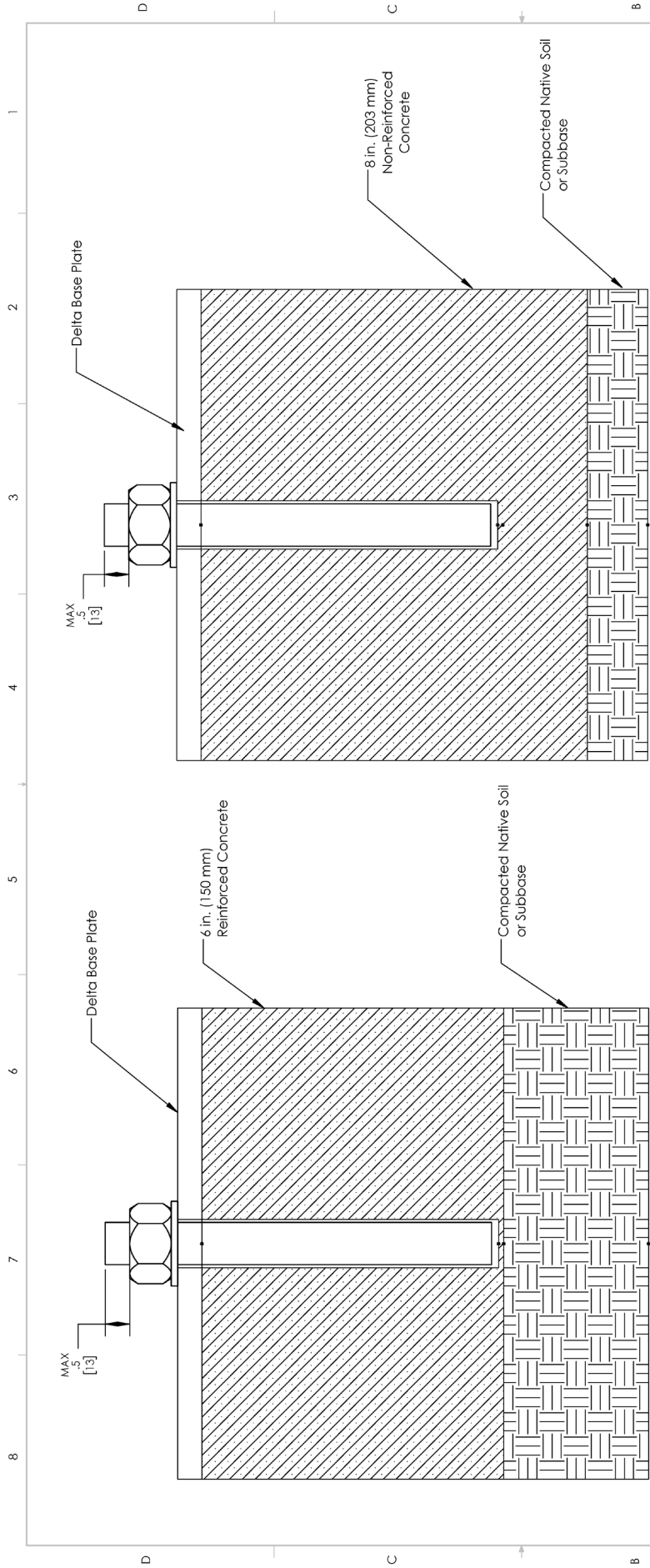

6 IN. (150 mm) MIN REINFORCED CONCRETE PAD
 *SEE SUGGESTED REBAR LAYOUT IN INSTALLATION MANUAL

8 in. (203 mm) MIN NON-REINFORCED CONCRETE PAD

LEGEND

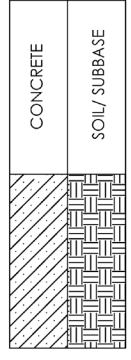

- 3. Anchor Rod Shall not Extend More Than .5 in. (13 mm) Past Anchor Nut;
 - 2. Concrete Shall Have a Minimum Compressive Strength of 4000 PSI (28 MPa) in 28 Days.
 - 1. Units: inches (mm)
- NOTES: Unless Otherwise Specified**

UNLESS OTHERWISE SPECIFIED: TOLERANCES: DIMENSIONS ARE IN INCHES (MM). DECIMALS: .125, .250, .375, .500, .625, .750, .875, 1.000 FRACTIONS: 1/8, 1/4, 3/8, 1/2, 5/8, 3/4, 7/8 ANGLES: TO NEAREST 10 MINUTES DECIMALS: .031, .062, .094, .125, .156, .188, .219, .250, .281, .312, .344, .375, .406, .438, .469, .500, .531, .562, .594, .625, .656, .688, .719, .750, .781, .812, .844, .875, .906, .938, .969, 1.000		TraFFix Devices Inc.  160 Avenida La Plata San Jose, CA 95128 (949) 351-5663 FAX (949) 361-9205 www.traffixdevices.com
TITLE: Delta Foundation Examples		
DRAWN BY: Robby Ramirez CHECKED BY: GJM APPROVED BY: GJM	DATE: 03/15/21 DATE: 03/15/21 DATE: 03/15/21	
SIZE: B	DRAWING NO.: 1110	
REV: A1		
SHEET 1 OF 2		

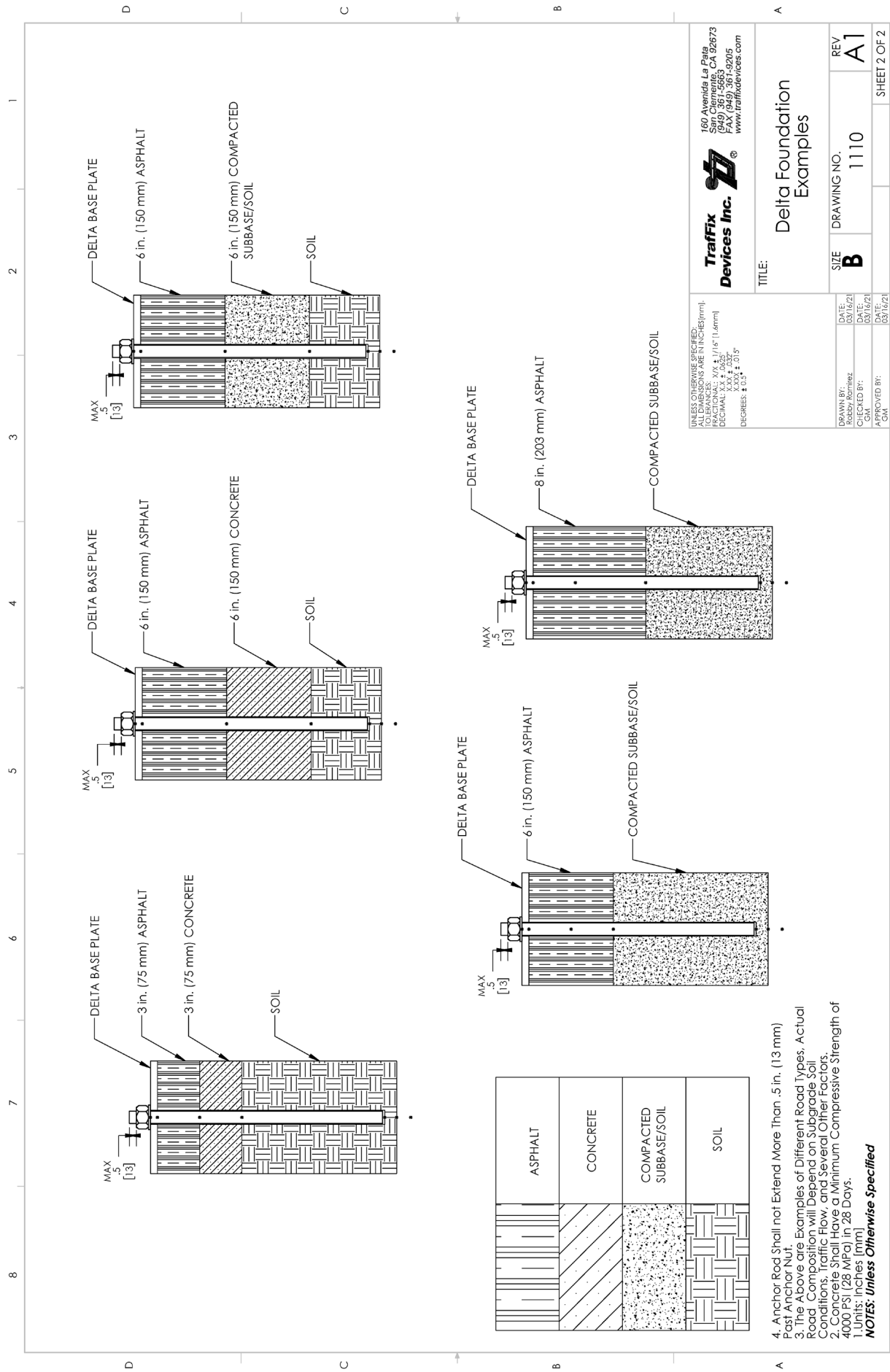

UNLESS OTHERWISE SPECIFIED:
 TOLERANCES ARE IN INCHES (mm)
 DECIMALS: .1 (2.5)
 FRACTIONS: 1/16 (1.6mm)
 ANGLES: ± .03°
 DEGREES: ± 0.5°

Traffix Inc.
 160 Avenida La Palms
 San Dimas, CA 91763
 (949) 361-5563
 FAX (949) 361-9205
 www.traffixdevices.com

Delta Foundation Examples

DATE: 03/16/21
 DRAWN BY: Robby Ramirez
 CHECKED BY: GM
 APPROVED BY: GM

DATE: 03/16/21
 DATE: 03/16/21
 DATE: 03/16/21

SIZE: **B**
 DRAWING NO.: 1110
 REV: **A1**

SHEET 2 OF 2

- Anchor Rod Shall not Extend More Than .5 in. (13 mm) Past Anchor Nut.
 - The Above are Examples of Different Road Types. Actual Road Composition will Depend on Subgrade Soil Conditions, Traffic Flow, and Several Other Factors.
 - Concrete Shall Have a Minimum Compressive Strength of 4000 PSI (28 MPa) in 28 Days.
1. Units: inches [mm]
NOTES: Unless Otherwise Specified

This Page Intentionally Left Blank

TraFFix Devices University

Chekout our Delta Online Training
Courses!

Scan Me!



Or visit <https://go.bluevolt.com/TraFFix/s/>

from your computer, tablet, or mobile device!





Notes



Regional Sales Manager

<p>Northeast Territory Office VA, WV, DE, MD, NJ, NY, PA, CT, MA, RI, NH, VT, ME, D.C. Mike Herlehy Rochester, NY (585) 267-9970 Office (949) 573-9239 Fax mherlehy@traffixdevices.com</p>	<p>Southeast Territory Office TN, NC, SC, GA, MS, AL, FL Lary Hudoff Miami, FL (770) 778-8281 Office (949) 325-6059 Fax lhudoff@traffixdevices.com</p>
<p>Northwest Territory Office MT, UT, ID, WA, OR, NV, CO, WY Cary LeMonds St. George, UT (801) 979-7099 Office (949) 573-9290 Fax clemonds@traffixdevices.com</p>	<p>Midwest Territory Office OH, MI, IN, KY, IL, WI, MN, ND, SD, IA, MO Dave H. Lindquist Chicago, IL (630) 605-1273 Office (949) 573-9240 Fax dlindquist@traffixdevices.com</p>
<p>Western Territory Office CA, HI, AK, AZ Lawrence Berg San Diego, CA (949) 350-7048 Office (949) 573-9267 Fax lberg@traffixdevices.com</p>	<p>Southwest Territory Office TX, OK, KS, NE, NM, AR, LA John Gense Dallas, TX (214) 704-1476 Office (949) 573-9291 Fax jgense@traffixdevices.com</p>
<p>V.P. Global Sales Chris Giordano Jacksonville, FL (216) 233-3273 Office (949) 573-9264 Fax cgiordano@traffixdevices.com</p>	<p><u>To Place Orders</u> Email: orders@traffixdevices.com Office: (949) 361-5663 Fax: (949) 573-9250</p>



Customer Support Services

Traffix Devices, Inc. Headquarters

160 Ave. La Pata, San Clemente, CA 92679

Email : info@traffixdevices.com

Phone: (949) 361-5663 Fax: (949) 573-9250

Hours: Monday - Friday

7:30 AM - 4:30 PM

www.traffixdevices.com

