

Scorpion II® Trailer Attenuator Assembly Manual and Mounting Instruction Guide

(For Model: Scorpion II® Series 10002 TA)

This Manual is Available at www.traffixdevices.com

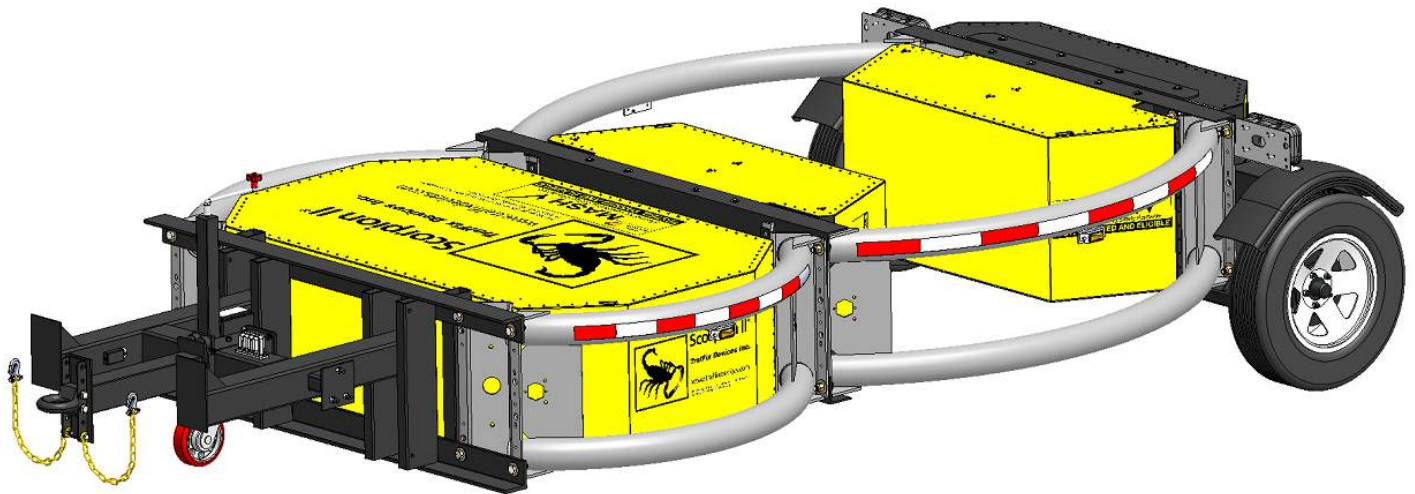

160 Avenida La Pata
San Clemente, CA 92673

This Page is Intentionally Left Blank

Scorpion II® 10002 TA

Introduction to Assembly and Mounting Instruction Guide



160 Avenida La Pata

San Clemente, CA 92673

www.traffixdevices.com orders@traffixdevices.com



Important: These instructions pertain only to the assembly and mounting of the Scorpion II 10002 Trailer Attenuator (TA). These instructions are only for the assembly of the models and/or accessories cited in each section. Any deviation from the models and accessories shown would require consultation with the appropriate highway authority engineer and/or certified TrafFix Devices, Inc. representatives. Contact information of these representatives can be found on the last page of this manual (Pg.26).

Proper Installation of the Scorpion II Trailer Attenuator (TA) is essential for proper performance of the system. For this reason, contacting a TrafFix Devices, Inc. Certified Attenuator Installer for assistance in mounting the system is recommended. Contact TrafFix Devices, Inc. to obtain a list of Certified Installers in the area. Please read this manual in its entirety before assembling, installing, or operating the Scorpion II TA. The information in this Manual supersedes all previous versions and manuals, with updated illustrations and other information available at time of printing; however, TrafFix Devices, Inc. reserves the right to make changes at any time. **For any questions on proper Installation and Operation of the Scorpion, please contact us at (949) 361-5663.**



Important: This manual applies to the Scorpion II® Trailer Attenuator by TrafFix Devices, Inc. It pertains only to the models referenced herein. It requires that all Assembly, Mounting, Service and Repair parts be Genuine Scorpion parts that have not been modified or repaired from the original in any way, unless with prior knowledge, consultation and approval by TrafFix Devices, Inc. Engineering.

Table of Contents

	Page
Limitations and Warnings/ Safety Instructions Scorpion II Trailer Attenuator (TA)	iv
Operating Instructions	1
General Maintenance/ After Impact Removal & Repair	2
Scorpion II TA TL-3 Major Components/ Parts List	3-4
Telescoping Anti-Rotational System (TARS)	5-8
TL-3 Scorpion II TA Assembly	9-14
Electrical Support Drawings	15-21
TA Limited Warranty	22
Notes/ Important Contact Information	23-26

Limitations and Warnings

TrafFix Devices Inc. (TDI), in compliance with the Manual for Assessing Safety Hardware (MASH) recommended procedures for the Safety Performance of Highway Features. TDI contracts with ISO accredited testing facilities to conduct crash tests, evaluation of tests, and submittal of results to the Federal Highway Administration for Eligibility for Federal-Aid Reimbursement. The Scorpion II Trailer Attenuator (TA) system was tested to meet the safety evaluation guidelines of MASH. The Scorpion II has been tested at TL-3 (62.1 mph/100 km/hr) speed impact conditions. These tests are intended to evaluate product performance by simulating those impacts outlined by MASH involving a range of vehicles on the roadways, from cars with an approx. weight of 2425 lbs. [1100 kg] to trucks with an approx. weight of 5004 lbs. [2270 kg]. The Scorpion II TA is a TL-3 tested device capable of decelerating and stopping the light and heavy weight vehicles 2425 lbs. [1100 kg] and 5004 lbs. [2270 kg] in accordance with the criteria of Tests 3-50, 3-51, 3-52, and 3-53 for TL-3 (62.1 mph/ 100 km/hr) for FHWA Eligibility. Reference FHWA Eligibility letter CC-138. Additionally, the Scorpion II TA was tested to meet the requirements of TD 49/07 UK. These tests are based on the requirements for Lorry Mounted Crash Cushions from the Highways England Road Ministry. These specified tests are not intended to represent the systems performance when impacted by every vehicle type or every impact condition existing on the roadway. This system is tested only to the test matrix criteria of MASH and TD 49/07 UK. TrafFix Devices does not represent nor warrant that the results of these controlled tests show that vehicle impacts with the products in other conditions would necessarily avoid injury to person(s) or property. Impacts that exceed the systems specifications may not result in acceptable crash performance as outlined in MASH; relative to structural adequacy, occupant risk, and vehicle trajectory. TDI expressly disclaims any warrant or liability for injury or damage to person(s) or property resulting from any impact, collision, or harmful contact with products, other vehicles, or nearby hazards or objects by any vehicle, object or person, whether or not the products were installed by third parties. The Scorpion II TA system is intended to be assembled, delineated, and maintained in accordance with specific State and Federal guidelines. TDI offers a reflective delineator panel for its TA line of products. However, the material is only intended to supplement delineation required by the Department of Transportation's "Manual on Uniform Traffic Control Devices" (MUTCD). The appropriate highway authority approved engineer should properly select, assemble, and maintain the product. Careful evaluation of the speed, traffic direction, and visibility are some of the elements that require evaluation for the proper selection of a safety appurtenance by the appropriate specifying highway authority.

Safety Instructions

Scorpion II Trailer Attenuator (TA)

- A. Before attempting to install or operate the Scorpion II 10002 TA, this manual should be read and understood. Those areas with warnings or cautions should be carefully followed.
- B. Before operation on the roadway, check all fasteners between the Tongue, Strut and Cartridge areas for tightness and excessive wear.
- C. Check lug nuts for proper torque values to 95 ft-lbs.
- D. Check that the single crank jack is fully retracted and up in the locked pinned position before transport.
- E. Inspect all lights for proper function.
- F. For correct TA operation in the use mode, the entire TA should be 12" ± 1" [30.48cm ± 2.54cm] above the ground and horizontal to the roadway.
- G. The responsible agency for the truck should check that the following specifications are met. The truck should have a minimum weight of 12,000 lbs. [5,443 kg]. It should be equipped with proper operator safety equipment such as seat belts, headrest, etc. If ballast is needed, it should be properly anchored to the truck frame to prevent movement during an impact.
- H. Before disconnecting the TA from the truck, make sure the TA rear wheels are chocked to prevent rolling when removed from truck.

Operating Instructions

Proper Operation includes knowledge of TA use in Work Zones, both Moving and Stationary, including the proper spacing, to allow for “roll-ahead”. Before use, the Operator should have prior knowledge/discussion of the Work Zone in which the TA will be deployed and that the TA model used has been tested to Test Level 3 = 100 kph/62 mph. TA’s should only be operated by individuals properly trained in their use in work zones.

Pre-Use Inspection

1. Walk around the unit inspecting for damaged, loose, or missing bolts, pins, cotter pins and safety snaps.
2. Inspect for damage to the energy absorbing modules and aluminum tubes, checking for deep gouges, deep scratches, warping, or cracking.
3. Inspect the steel structure for damage, looking for warping, cracks, breaks or other damage.
4. Inspect all lights for proper operation (including arrowboard, VMS, and Display Panel if applicable).
5. Check road clearance of TA in deployed mode, to ensure it is in specification (12 inches \pm 1 inch).
7. Ensure that retroreflective sheeting is in place and meets requirements for the job.
8. Check to ensure that there are no loose items on the truck that can become a projectile during an impact.
9. Make sure items in the cab of the vehicle are secure and cannot come loose and become a projectile should an impact occur.
10. Adjust the headrest properly for the driver of the vehicle.
11. Any deficiencies should be corrected before use.

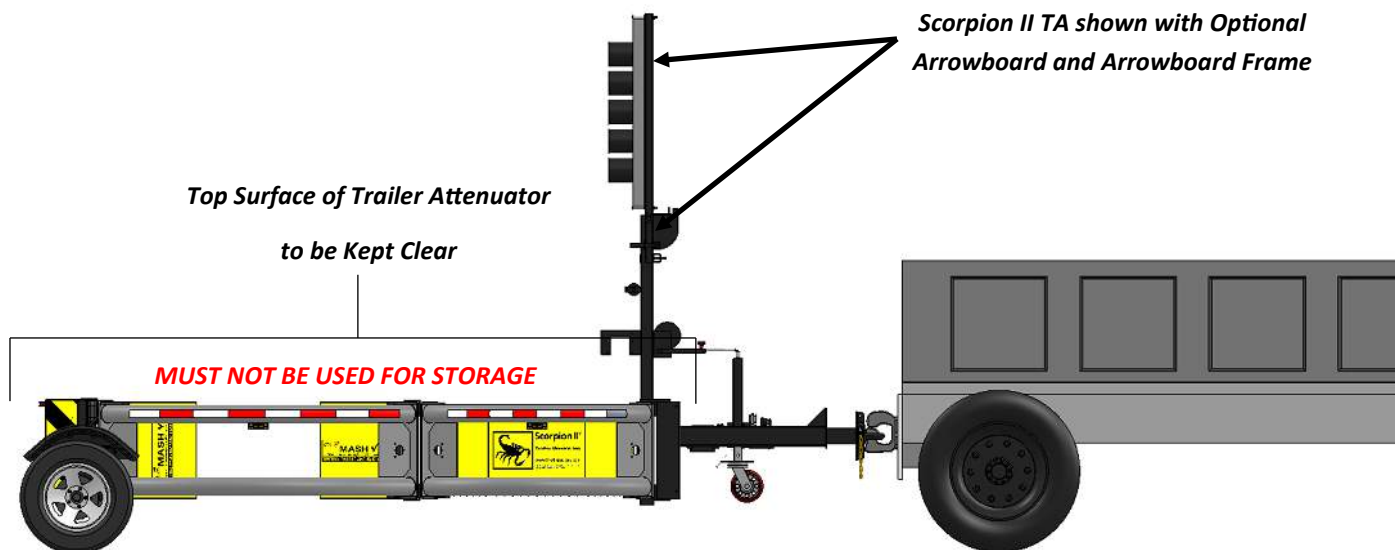

General Maintenance

Item to Service	Frequency
1. Check all fasteners between the TARS, Strut and Cartridge areas for tightness and excessive wear.	Check before driving
2. Check for levelness and that the height 12" ± 1 " [30.48cm \pm 2.54cm] clearance with the truck weight with a minimum of 12,000 lbs. [5,443 kg]	Check before driving
3. Check Module bolts that attach all modules for tightness.	Check before driving
4. Grease jack, caster, and wheel bearings.	As required
5. Replace light bulbs.	As required

After Impact Removal & Repairs

1. Disassemble system and mark for replacement, all bent and damaged parts.
2. Write down all part numbers for those items that need replacing – only Traffix Devices, Inc. replacement parts can be used to return the repaired TA to as-manufactured condition.
3. After receiving replacement parts verify that the new part fit against the older parts and proceed to assemble per the installation manual.
4. After a vehicle impacts the TA, do not drive the truck with the damaged TA. Remove the TA at the pintle hook and have the TA transported back to the maintenance yard.

Scorpion II TA TL-3 Major Components

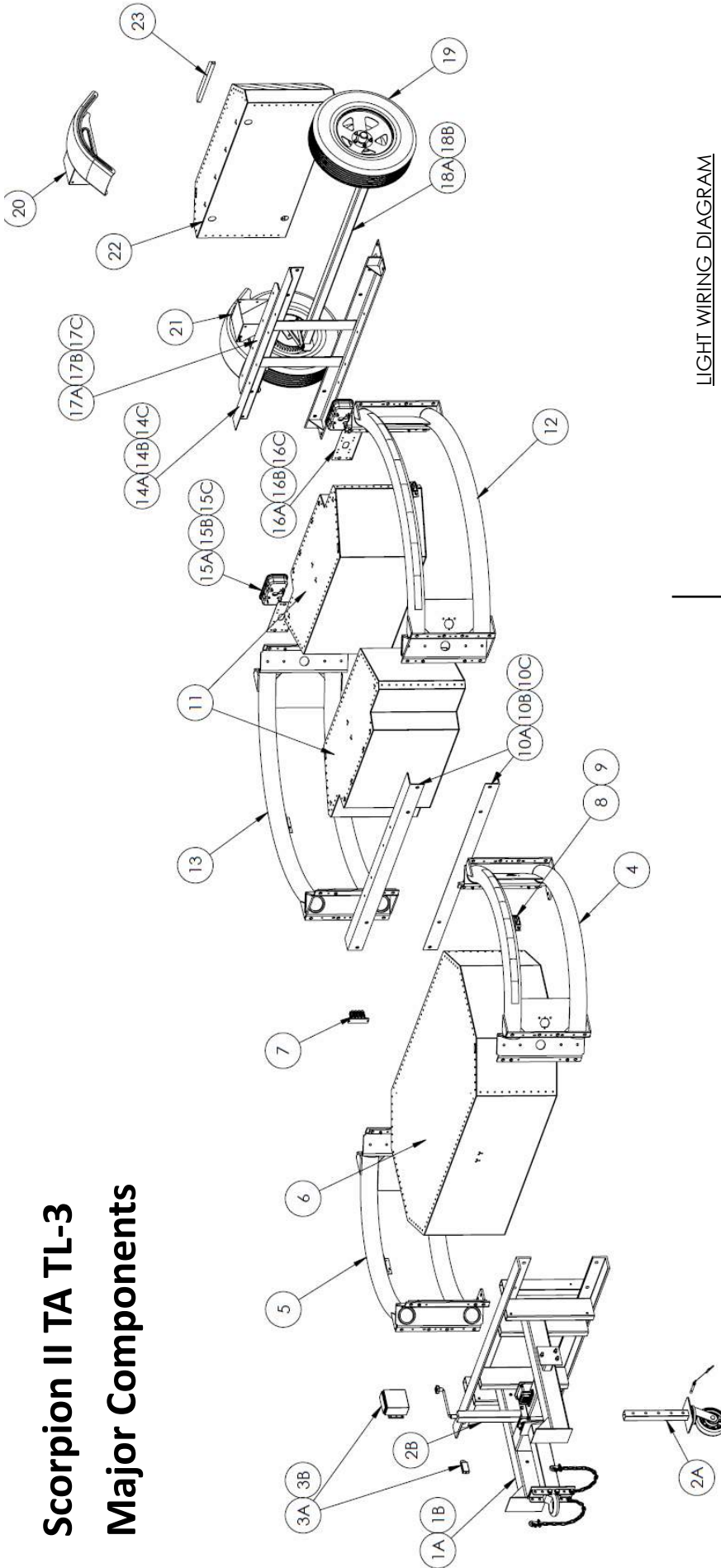

BRAKE WIRING DIAGRAM

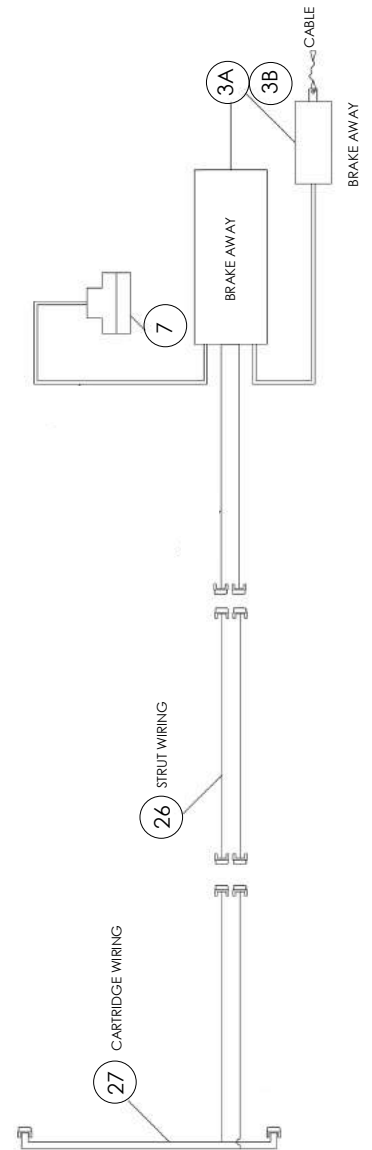

LIGHT WIRING DIAGRAM

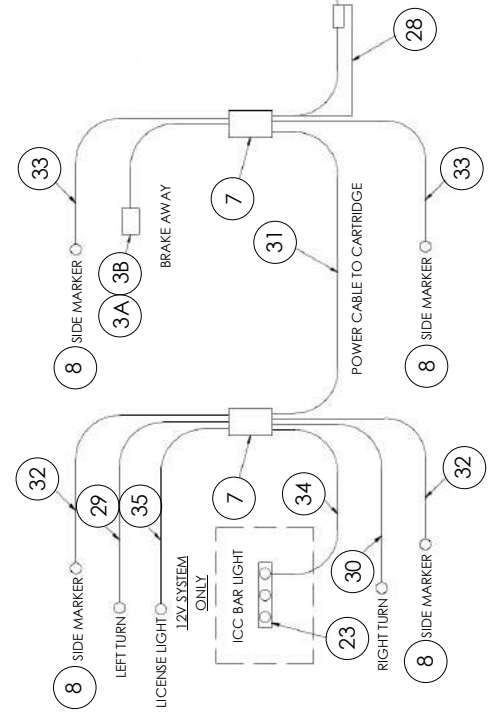

Scorpion II 10002 TA TL-3 Parts List - Major Components

Item #	Part #	Item Description	QTY/TA
1A	13100	Tongue Assembly, Black Paint	1
1B	13100G	Tongue Assembly, Galvanized	1
2A	13234	Jack, Inner Post w/ Caster	1
2B	13232	Jack Mechanism	1
3A	13154A	Engager, Brake-Away 12V System	1
3B	13154A-24V	Engager, Brake-Away 24V System	1
4	10200TL-MASH-KIT	Strut Tube Assy, LH, Includes C-Tape, Warning Labels, Marker Light Bracket	1
5	10200TR-MASH-KIT	Strut Tube Assy, RH, Includes C-Tape, Warning Labels, Marker Light Bracket	1
6	13300D	Module D Energy Absorber, Scorpion II Trailer	1
7	10518	Junction Block	2
8	10573	Side Marker Light, 10-30 volt, LED	4
9	10520	Housing, Side Marker Light	4
10A	13305	Diaphragm Angle, Powder Coated Steel	2
10B	13305G	Diaphragm Angle, Galvanized	2
10C	13366	Diaphragm Angle, Aluminum	2
11	11400C	Module C Energy Absorber, Scorpion II	2
12	10100L-MASH-KIT	Cartridge Tube Assy, LH, Includes C-Tape, Warning Label, Marker Light Bracket	1
13	10100R-MASH-KIT	Cartridge Tube Assy, RH, Includes C-Tape, Warning Label, Marker Light Bracket	1
14A	13360	Rear Diaphragm, Powder Coated Black	1
14B	13360G	Rear Diaphragm, Galvanized	1
14C	13320	Rear Diaphragm, Aluminum	1
15A	10516A-LED	Tail Light Assembly, RH, 10-30 Volt LED, Color Pattern: Red/Red/ White	1
15B	10505A-LED-RYR	Tail Light Assembly, RH, 10-30 Volt LED, Color Pattern: Red/Amber/Red	1
15C	10505A-LED-YRW	Tail Light Assembly, RH, 10-30 Volt LED, Color Pattern: Amber/Red/ White	1
16A	10508A-LED	Tail Light Assembly, LH, 10-30 Volt LED, Color Pattern: Red/Red/ White	1
16B	10504A-LED-RYR	Tail Light Assembly, LH, 10-30 Volt LED, Color Pattern: Red/Amber/Red	1
16C	10504A-LED-YRW	Tail Light Assembly, LH, 10-30 Volt LED, Color Pattern: Amber/Red/ White	1
17A	10465	Rear Top Angle, Powder Coated Black	1
17B	10465G	Rear Top Angle, Galvanized	1
17C	13167	Rear Top Angle, Aluminum	1
18A	13230	Axle w/ Electric Brakes, 3,500 lb, Powder Coated	1
18B	13231	Axle w/ Electric Brakes, 3,500 lb, Galvanized	1
19	13260	Wheel and Tire	2
20	13240P-L	Plastic Fender Assy, LH, w/ Mounting Bracket, Hardware, & 12V LED Light	1
21	13240P-R	Plastic Fender Assy, RH, w/ Mounting Bracket & Hardware	1
22	10400A	Module A Energy Absorber, 4" Yellow/Black Chevron Pattern	1
23	10557	ICC Bar Light, 12V, LED	1
26	13276	Electric Brake Cable, Strut	1
27	13274	Electric Brake Cable, Cartridge	1
28	10511A	Power Cable, 7 Way Plug	1
29	10519	Tail Light Cable Harness, LH, 120"	1
30	10509	Tail Light Cable Harness, RH, 120"	1
31	10510	Cartridge Power Cable, 144"	1
32	10512	Side Marker Light Cable, Strut, 144"	2
33	10513	Side Marker Light Cable, Cartridge, 180"	2
34	10556	ICC Bar Light Cable, 168"	1
35	13277	License Plate Light Cable	1

Telescoping Anti-Rotational System (TARS)

The steel tongue is a single point trailer attachment for towing the TA under normal use with a built-in anti-rotation design that activates a three-point contact engagement support when the TA is impacted. The single point trailer attachment with the anti-rotation design is called the Telescoping Anti-Rotation System (TARS) and is only activated when the TA is impacted. Under normal stationary or mobile use, the TARS acts as a single point trailer attachment. When the TA is impacted, the TARS tongue telescopes forward and a set of outboard anti-rotation supports contact the frame plate on the support vehicle preventing the Trailer Attenuator from rotating about the pintle hook and the rear of the support vehicle.

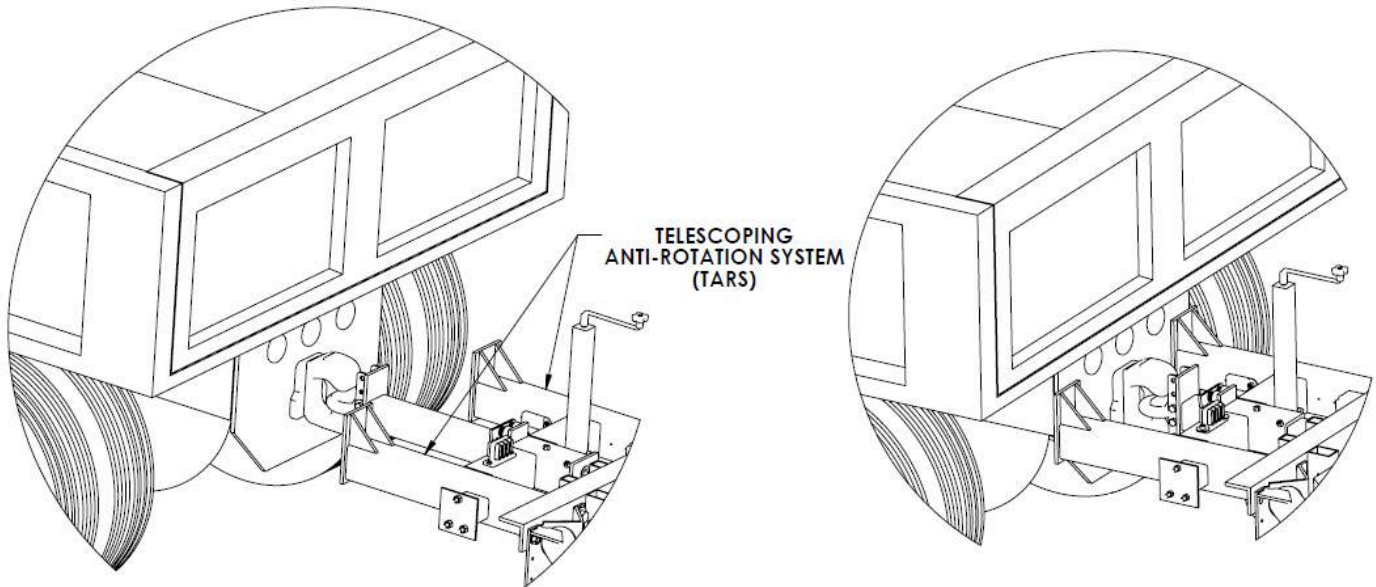

**FULL MOUNTING PLATE PREPARATIONS FOR THE
TRAFFIX DEVICES SCORPION II TRAILER ATTENUATOR
W/ TELESCOPING ANTI-ROTATION SYSTEM (TARS)
PLEASE REFERENCE FHWA MASH ELIGIBILITY LETTER HSST/CC-138
FOR PROPER HOST VEHICLE WEIGHT**

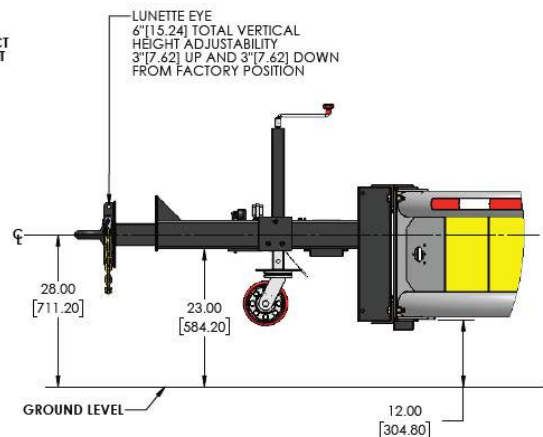
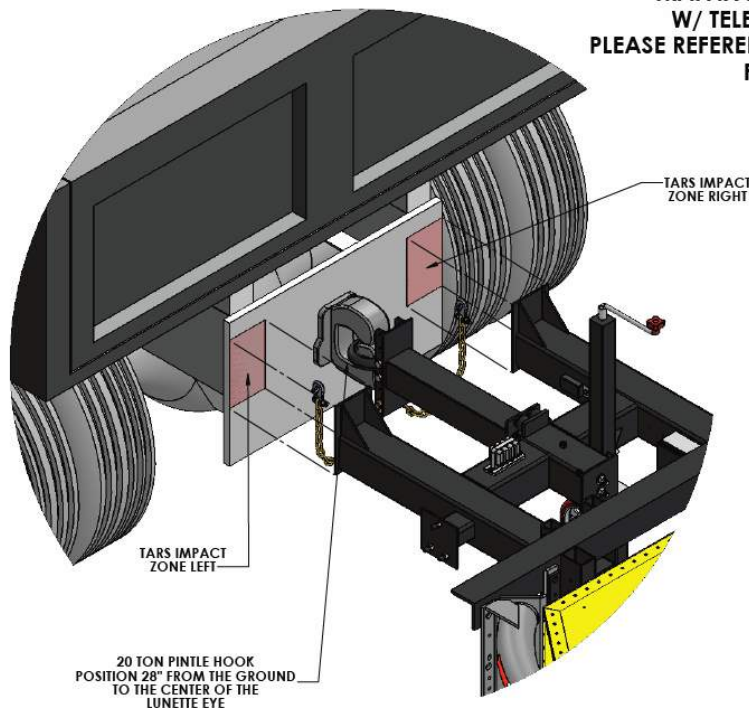

8 7 6 5 4 3 2 1

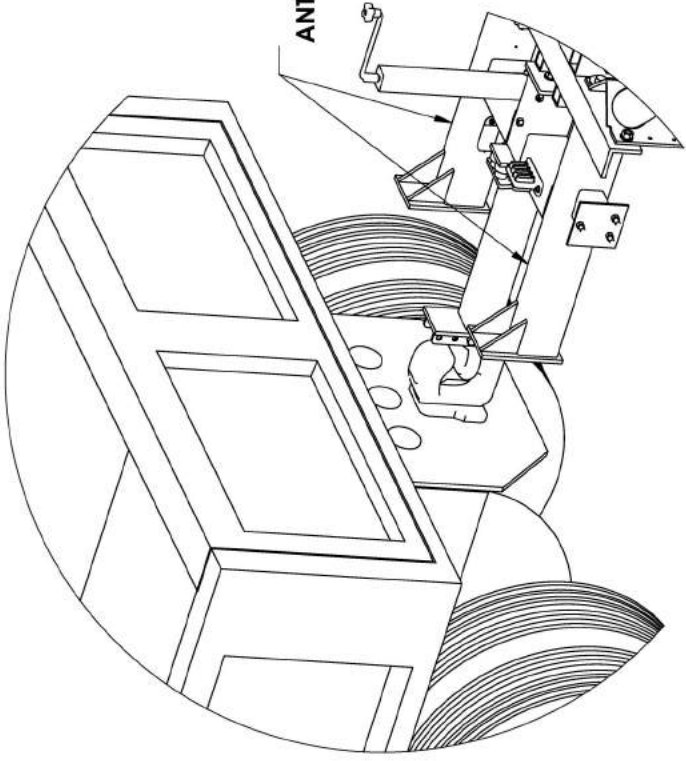

TELESCOPING ANTI-ROTATION SYSTEM (TARS)

PRE-IMPACT CONDITION POSITION DURING NORMAL OPERATIONAL USE

TRAFFIX DEVICES TRAILER ATTENUATOR ATTACHES DIRECTLY TO THE PINTLE HOOK AND REQUIRES LITTLE OR NO ADDITIONAL INSTALLATION OR TRUCK MODIFICATION BEYOND THE FACTORY INSTALLED FRAME PLATE.

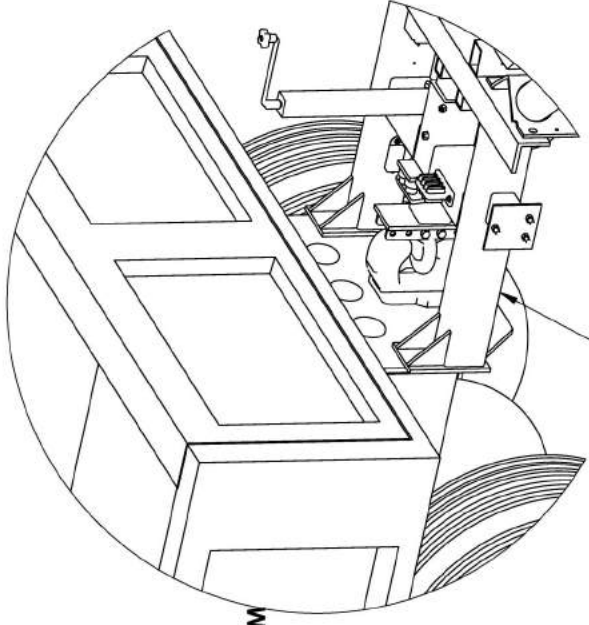

TELESCOPING ANTI-ROTATION SYSTEM (TARS) STOPS UP AGAINST THE FRAME PLATE PREVENTING ANGULAR ROTATION DURING THE IMPACT

POST-IMPACT CONDITION POSITION AFTER IMPACT EVENT HAS OCCURRED

 <p>169 Avenida Le Prie San Clemente, CA 92673 (949) 361-5663 www.traffixdevices.com</p>		<p>DATE: _____ DATE: _____ DATE: _____</p>	<p>DATE: _____ DATE: _____ DATE: _____</p>	<p>DATE: _____ DATE: _____ DATE: _____</p>	<p>DATE: _____ DATE: _____ DATE: _____</p>
<p>TRAFFIX DEVICES TRAILER ATTENUATOR</p>		<p>SIZE B</p>	<p>DWG. NO. 104</p>	<p>REV A</p>	<p>SHEET 1 OF 1</p>
<p>TITLE: PRE AND POST IMPACT TONGUE POSITIONS</p>					

TRAFFIX DEVICES TRAILER ATTENUATOR ATTACHES DIRECTLY TO THE PINTLE HOOK AND REQUIRES LITTLE OR NO ADDITIONAL INSTALLATION OR TRUCK MODIFICATION BEYOND THE FACTORY INSTALLED FRAME PLATE.

FACTORY INSTALLED FRAME PLATE

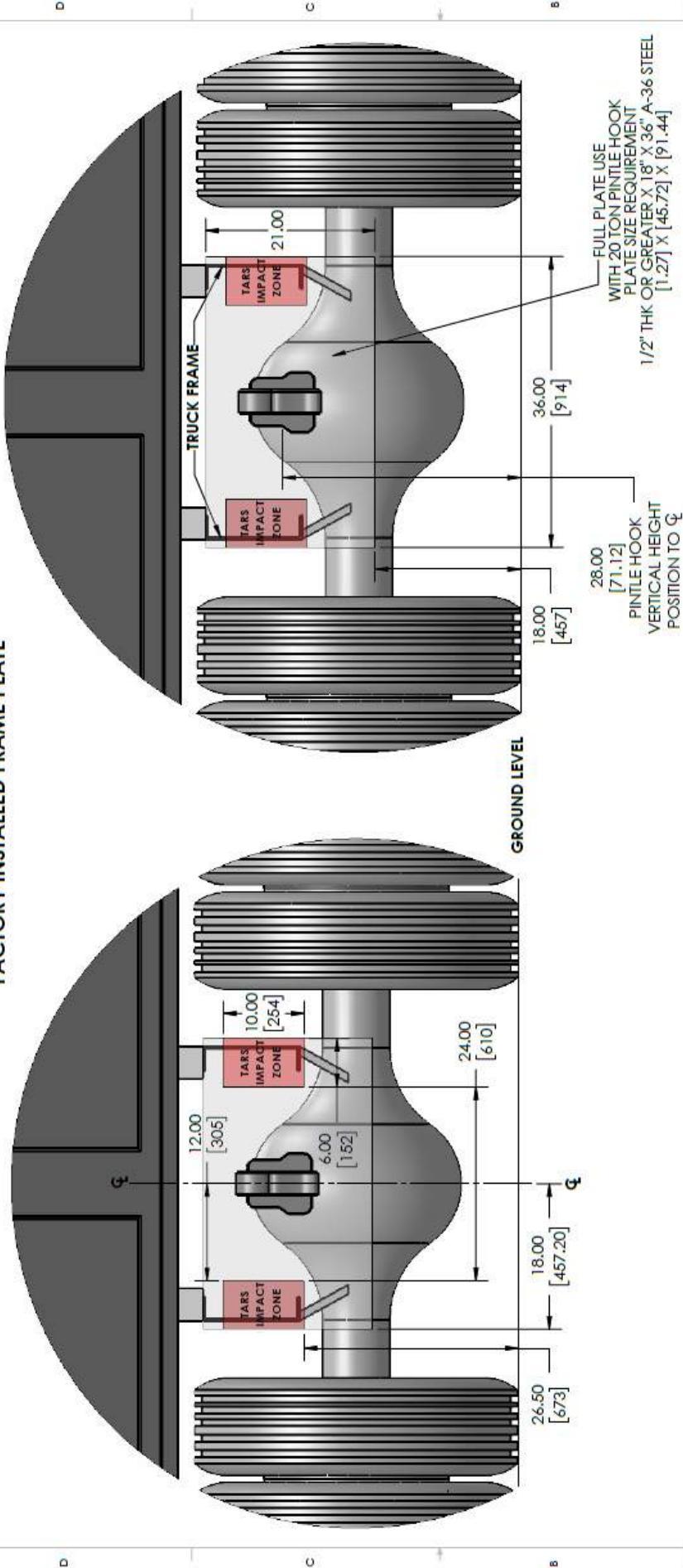

UNLESS OTHERWISE SPECIFIED:
ALL DIMENSIONS ARE IN INCHES(MM).

Traffix Devices Inc.
160 Avenida La Plata
San Clemente, CA 92673
(949) 340-3000
Fax: (949) 340-2905
www.traffixdevices.com

TITLE: TARS Impact Zone w/ Factory Installed Frame Plate

SIZE: B DWG. NO.: 900-201 REV: A

DRAWN BY: Christopher Jozma
CHECKED BY: DATE: 4/23/18
APPROVED BY: DATE: 4/23/18

FULL MOUNTING PLATE PREPARATIONS FOR THE TRAFFIX DEVICES SCORPION TRAILER ATTENUATOR W/ THE TELESCOPING ANTI-ROTATION SYSTEM (TARS) PLEASE REFERENCE FHWA MASH ELIGIBILITY LETTER HHST/CC-138 FOR PROPER HOST VEHICLE WEIGHT

TL-3 Scorpion II TA Assembly

1. **IMPORTANT:** Before beginning assembly, please read and review the Installation Section of this manual, paying close attention to the checklist at the beginning of the section.
2. Inspect the three pallets containing the Cartridge (left), Strut (middle), and the Tongue (right) shown below, for shipping damage and completeness against the packing list. If there is anything missing or not complete, contact a Traffix Devices representative as soon as possible.
3. **WARNING: TOP HEAVY**– Indicates to move pallets with extreme caution. The use of a forklift is preferred when handling pallets. All personnel should be kept clear when the pallets are being moved.
4. Remove the shrink-wrap from the pallets using a utility knife. **Caution: Be careful not to cut any wires or parts!**



CARTRIDGE PALLETIZED



STRUT PALLETIZED

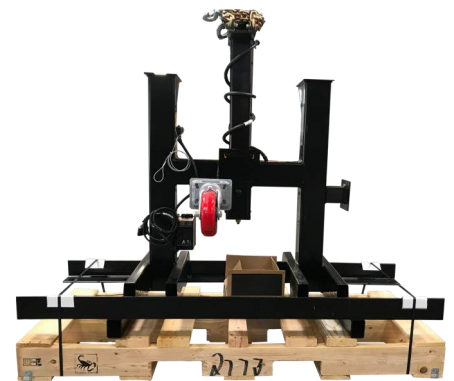

TARS TONGUE PALLETIZED

Recommended* Assembly Tools

1. Hammer
2. Tapered Pry Bar
3. Tape Measure
4. 12" Crescent Wrench
5. 1/2" Drive Socket Wrench
6. 1/2" Drive Socket (1-7/16")
7. Open End Wrenches (1-7/16", 3/4", 7/16")
8. 3/8" Drive Socket Wrench
9. 3/8" Drive Socket (7/16", 3/4")
10. Allen Wrench
11. Wire Cutter/Crimper
12. Floor Jacks or Stands (2 Ea.)
13. Forklift

**More or less tools may be needed.*

Assembly of Scorpion II Trailer Attenuator (TA) (TL-3)

1. Note that the Warning Top Heavy means that caution should be used in moving the pallets. Use fork extenders on forklift and keep all personnel away while moving. **Note: Components are heavy and cumbersome. It may take several people to properly set up the Scorpion II TA.**
2. Unpack the pallet by removing the shrink-wrap and cutting the steel bands. **Caution: It is possible that when the steel banding is cut the TA Cartridge and Strut may shift a few inches. Keep personnel away from the TA when the steel bands are cut. Keep a few feet away from pallet when pallet is pulled free of the Cartridge because it will shift a few inches.**

Remove Module A, Module C's, both fenders, and the wheels/tires from the Cartridge Section before it is taken off the pallet. Place TARS Tongue, Cartridge and Strut Sections in the horizontal position on a level work surface.

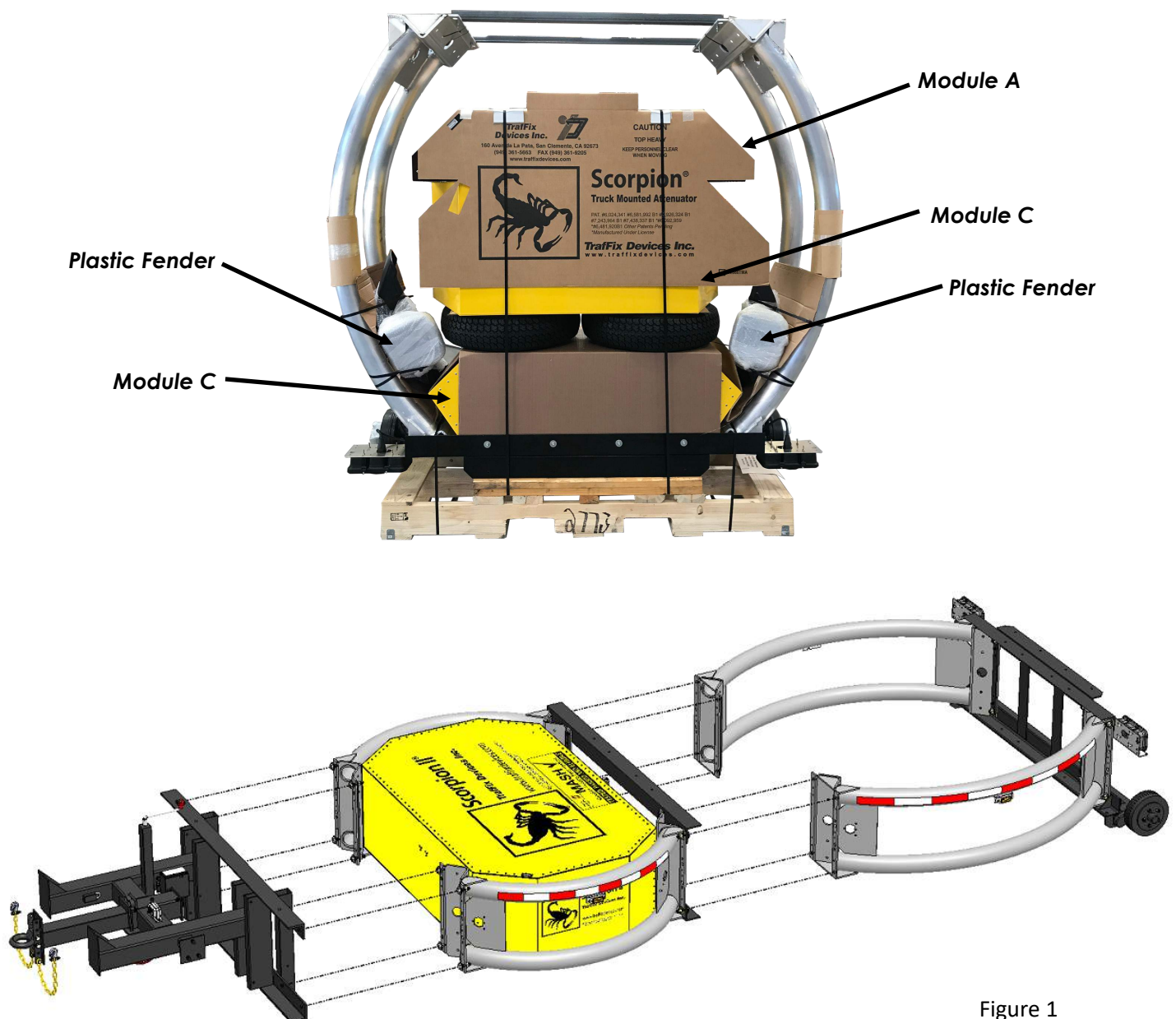

Figure 1

3. Remove the following parts from the Strut:

(8) 3/4"-10 x 2-1/2" Bolts **PN 12007**

(8) 3/4" USS Flat Washer **PN 12060**

(8) 3/4"-10 Nylock Nuts **PN 12008**

Position the Strut in front of the TARS Tongue and bolt as follows:

- Starting with the outboard hole on the top of the vertical angle of the Strut, thread the bolt, head towards the truck, through a washer, the hole in the TARS, and then the hole in the Strut. Once the bolt is through, secure with another washer and the Nylock nut. Repeat on the bottom and the other side.

- On the inboard hole on the top of the vertical angle of the Strut, thread the bolt, head towards the truck, through a washer, the hole in the TARS, and then the hole in the Strut. Once the bolt is through, secure with another washer and the Nylock nut. Repeat on the bottom and the other side.

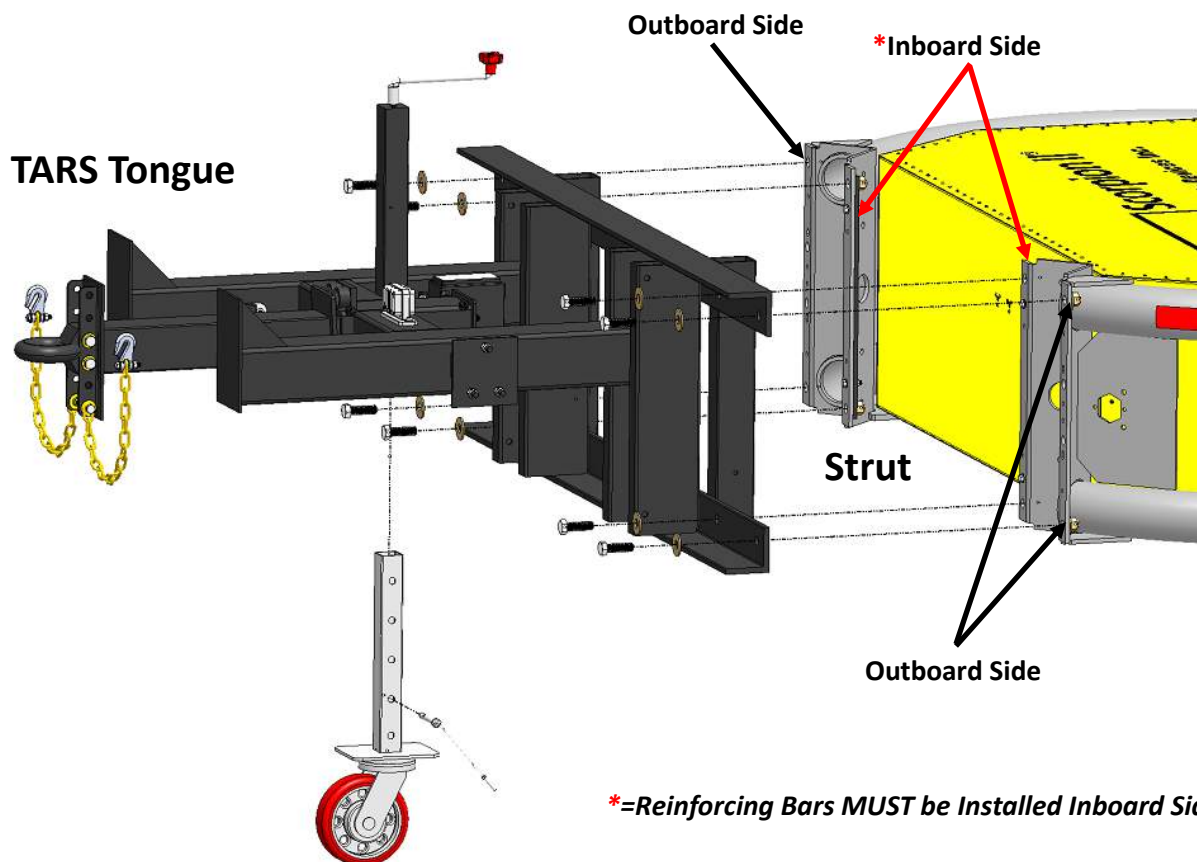

Figure 2

4. Remove the following parts from the Cartridge:

- (4) ¾"-10 x 2-½" Bolts **PN 12007**
- (4) ¾"-10 x 3" Bolts **PN 12351-ZUM-3.0**
- (8) ¾" USS Flat Washer **PN 12060**
- (8) ¾"-10 Nylock Nuts **PN 12008**

Position the assembled TARS Tongue/Strut in front of the Cartridge and bolt as follows:

- Starting with the outboard hole on the top of the vertical angle of the Cartridge, thread the bolt, head towards rear of TA, through a washer, the hole in the Cartridge, and then the hole in the Strut. Once the bolt is through, secure with another diameter washer and the Nylock nut. Repeat on the bottom and the other side.
- On the inboard hole on the top of the vertical angle of the Cartridge, thread the bolt, head towards the rear of the TA, through a washer, the hole in the Strut, and then the hole in the Cartridge. Once the bolt is through, secure with another washer and the Nylock nut. Repeat on the bottom and the other side.

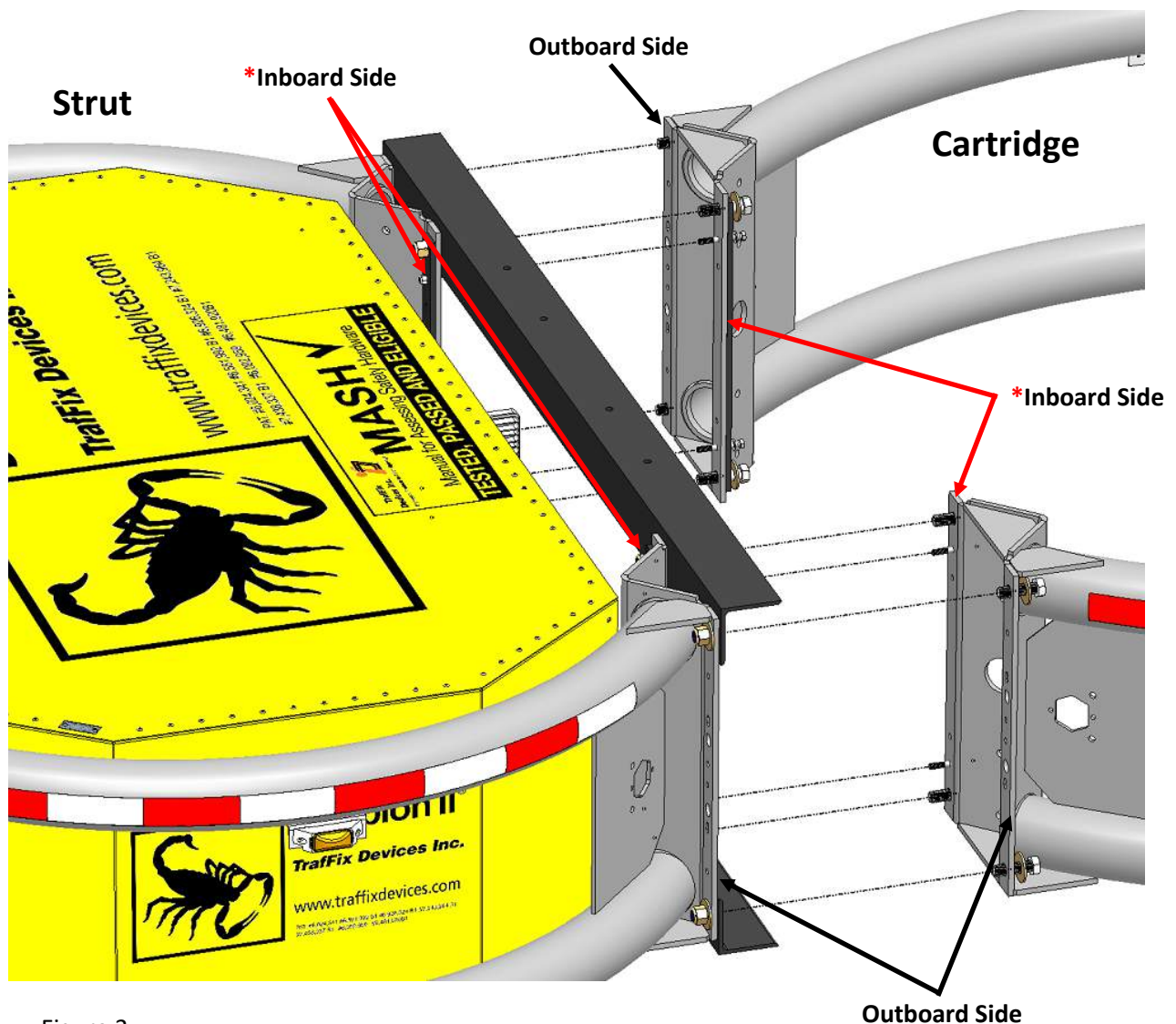

Figure 3

***=Reinforcing Bars MUST be Installed Inboard Side**

5. Install Module Box C, within the Cartridge section, to the top and bottom angles on the backside of the Strut. Torque the module bolts to a minimum of 20 ft-lbs.

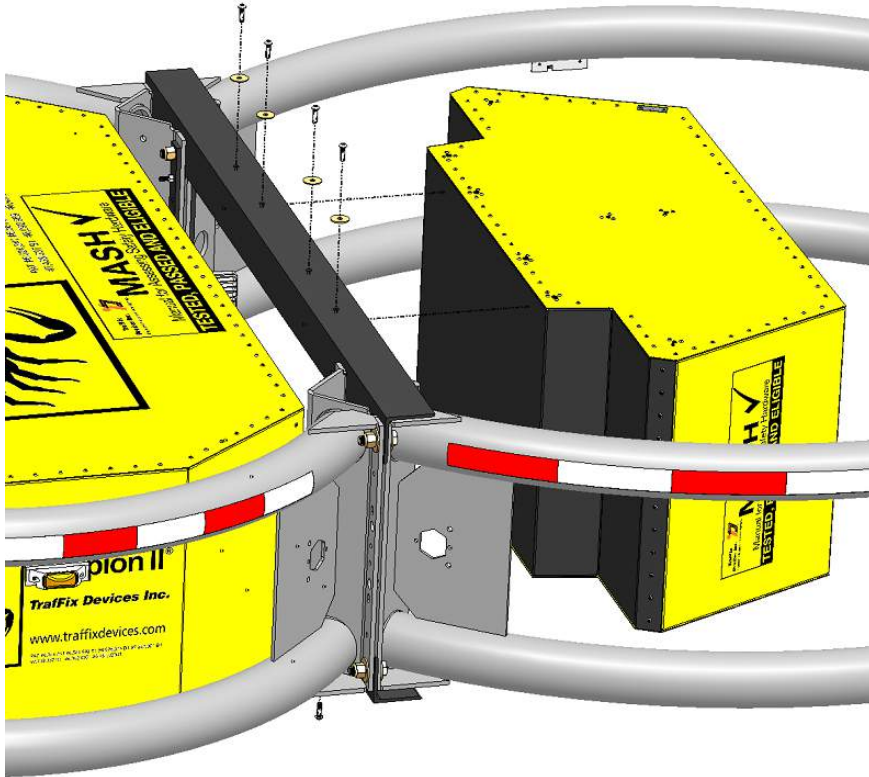

Figure 4

6. Install the second Module Box C to the top and bottom angles within the Cartridge section at the rear. Torque the module bolts to minimum of 20 ft-lbs.

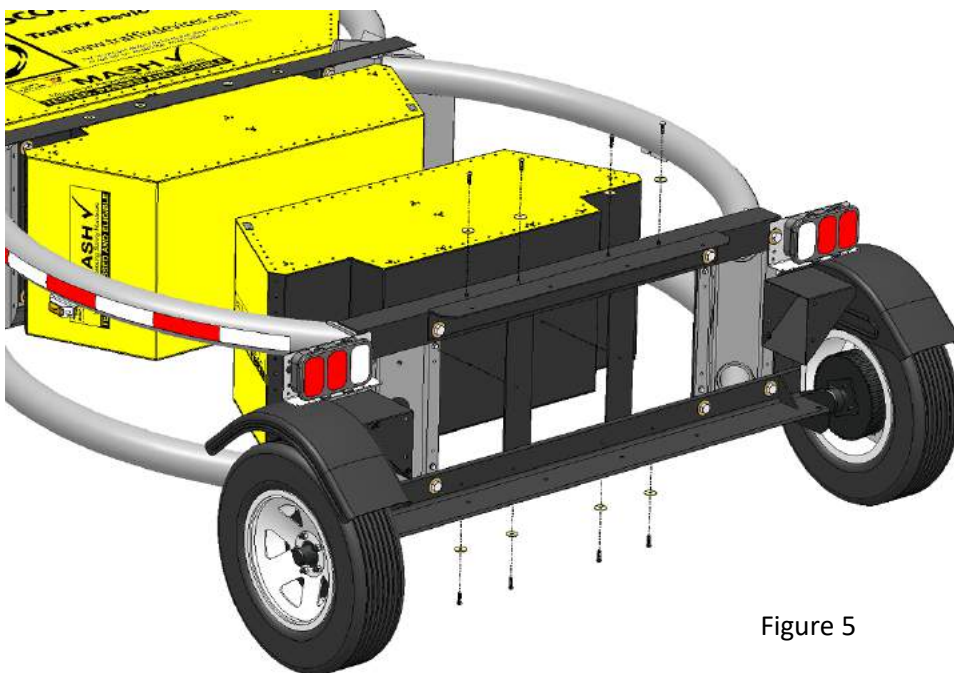

Figure 5

7. Install Module Box A to the top and bottom angles on the backside of the rear diaphragm. Torque the module bolts to minimum of 20 ft-lbs.

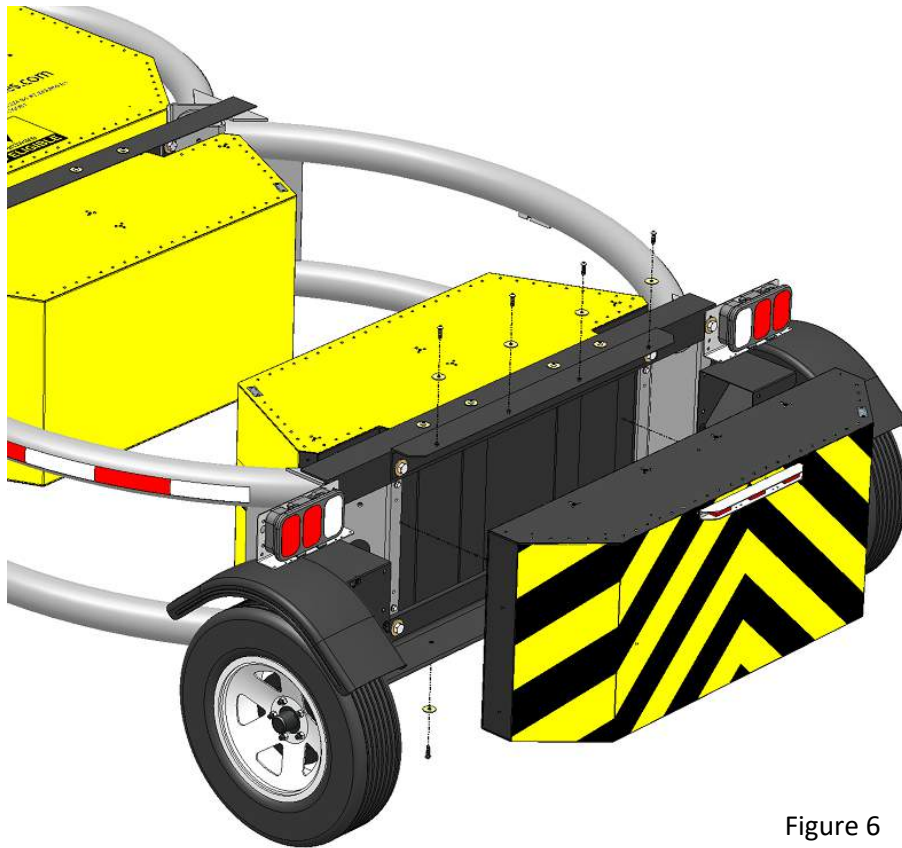
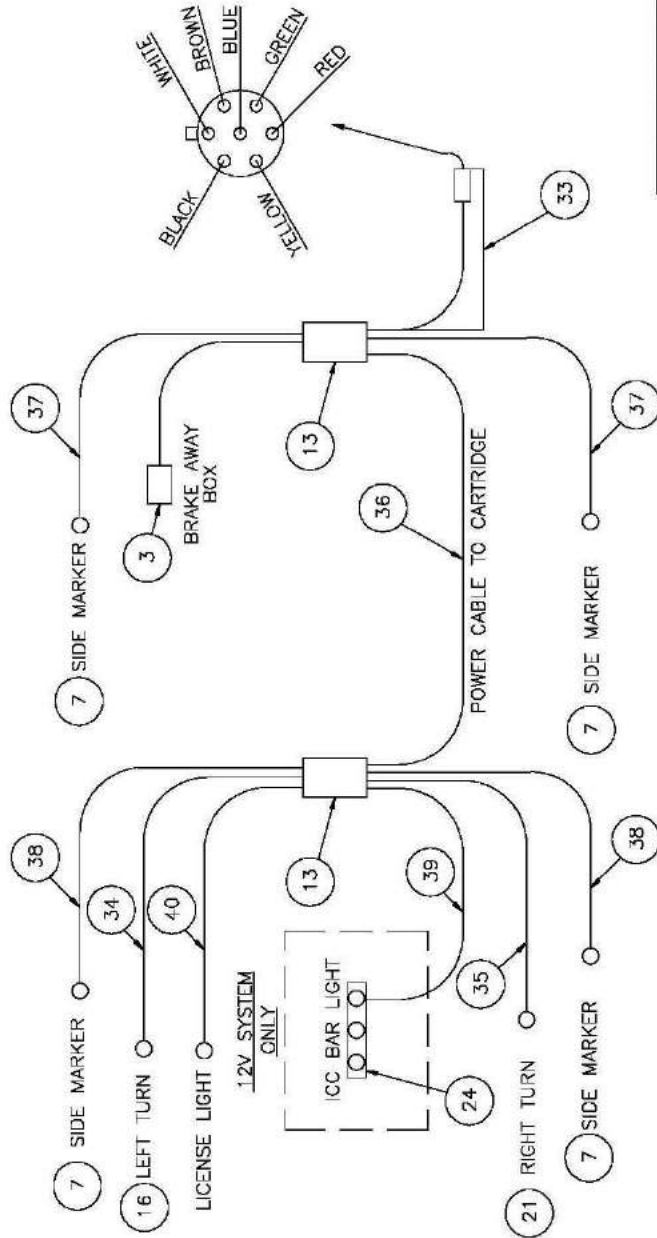

Figure 6

8. Remove the lug nuts from the studs on each of the axle. Install the fenders and wheel/tire and secure with lug nuts. Repeat for remaining side.
9. Plug the main power cable from the Strut into the electrical connector box on the Cartridge. Snap the wire retainers in place on the electrical connector box and wire tie the retainers together
10. The rear ICC bar light has two wires extending from it with plugs. Connect the plugs into the electrical wire plugs at the light. (Only use for 12V)
11. Connect the 7-pin electrical connector and verify that all the lights function correctly. (Refer to Wiring Schematic)
12. Hook up to appropriate host vehicle and road test the Scorpion TA.
13. Check all bolts for tightness after the road test and refer to the maintenance section of the manual to set up regular maintenance.

Electrical Support Drawings

LIGHT WIRING DIAGRAM



ELECTRICAL PARTS		
ITEM	DESCRIPTION	PN
3	BRAKE SWITCH ENGAGER	13154
7	SIDE MARKER LIGHTS-12 V	10502
	SIDE MARKER LIGHTS-24 V	10530
13	JUNCTION BOX	10518
16	LEFT TURN LIGHT-12 V	10508
	LEFT TURN LIGHT-24 V	10504
21	RIGHT TURN LIGHT - 12 V	10516
	RIGHT TURN LIGHT - 24 V	10505
24	ICC BAR LIGHT	10557
33	POWER CABLE TO STRUT	10511A
34	LEFT TURN WIRE HARNESS	10519
35	RIGHT TURN WIRE HARNESS	10509
36	POWER CABLE TO CARTRIDGE	10510
37	SIDE LIGHT HARNESS TO STRUT	10512
38	SIDE LIGHT HARNESS TO CARTRIDGE	10513
39	ICC BAR LIGHT CABLE	10556
40	LICENSE PLATE LIGHT WIRE HARNESS	13277

UNLESS OTHERWISE SPECIFIED:
ALL DIMENSIONS ARE IN INCHES.

TraFFix Devices Inc.
160 Avenida La Brea
San Clemente, CA 92678
(949) 361-5853
FAX (949) 361-5036
www.traffixdevices.com

TRAILER ATTENUATOR WIRING DIAGRAM

DRAWN BY:	DATE: 01/27/07	SIZE: B	DWG NO: 916	REV: E
CHECKED BY:	DATE:	SCALE: 1/1	SHEET: 1 OF 1	
APPROVED BY:	DATE:			

NOTES: UNLESS OTHERWISE SPECIFIED.

BRAKE WIRING SCHEMATIC

BRAKE WIRING PARTS		
ITEM	DESCRIPTION	PN
3	BRAKE SWITCH ENGAGER	13154
13	JUNCTION BOX	10518
28	BRAKE-AWAY PLUG	13275
29	BRAKE-AWAY BOX CABLE	13273
30	BRAKE STRUT WIRING	13276
31	CARTRIDGE/RIGHT WHEEL/ LEFT WHEEL CONNECTOR	13274

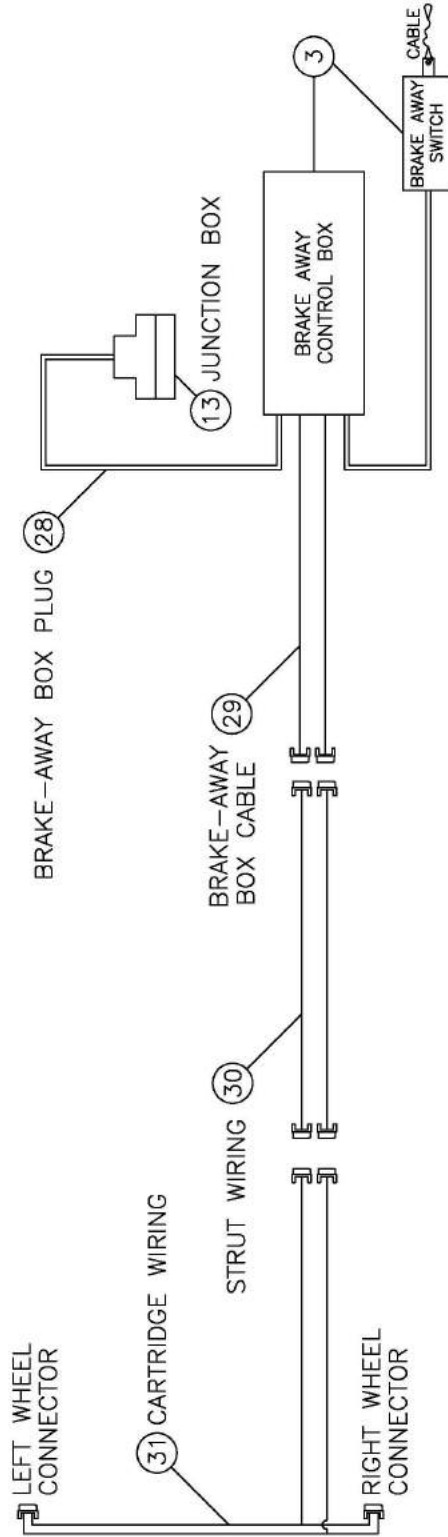

UNLESS OTHERWISE SPECIFIED:
ALL DIMENSIONS ARE IN INCHES.

DRAWN BY: _____ DATE: 11/01/07
 CHECKED BY: _____ DATE: _____
 APPROVED BY: _____ DATE: _____

Traffix Devices Inc.
 160 Avenida La Plata
 San Jose, CA 95073
 (949) 361-5653
 FAX (949) 361-5205
 www.traffixdevices.com

**TA BRAKE WIRING
DIAGRAM**

SIZE **B** DWG NO. **921** REV **C**
 SCALE **NTS** SHEET **1 OF 1**

NOTES: UNLESS OTHERWISE SPECIFIED.

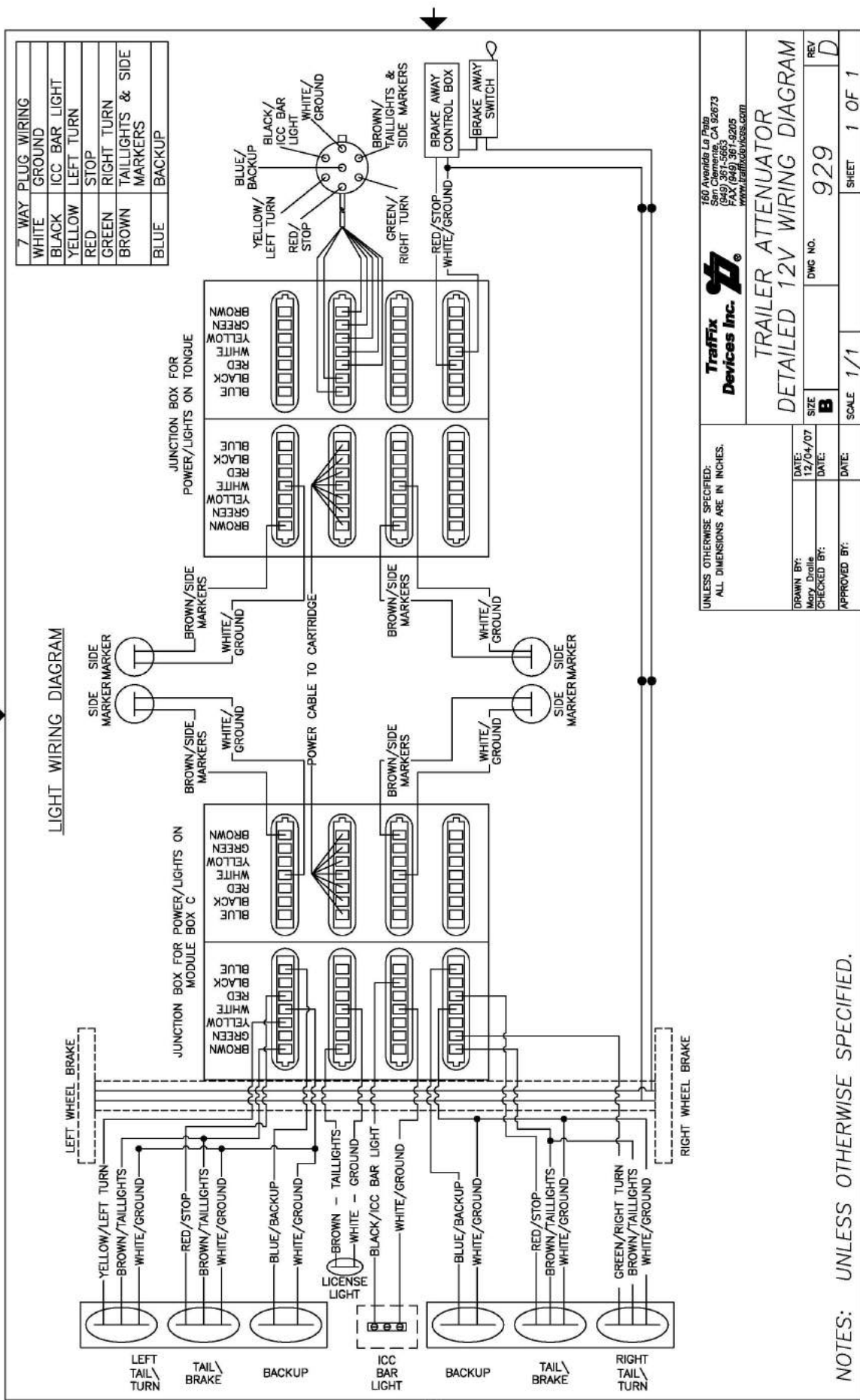

TraFFix Devices Inc.
 160 Avenida La Plata
 San Clemente, CA 92673
 (949) 361-5663
 FAX (949) 361-9206
 www.traffixdevices.com

**TRAILER ATTENUATOR
 DETAILED 12V WIRING DIAGRAM**

UNLESS OTHERWISE SPECIFIED:
 ALL DIMENSIONS ARE IN INCHES.

DRAWN BY: Mary Drollie	DATE: 12/04/07	SIZE B	DWG NO. 929	REV D
CHECKED BY:	DATE:	DATE:	SCALE 1/1	SHEET 1 OF 1

NOTES: UNLESS OTHERWISE SPECIFIED.

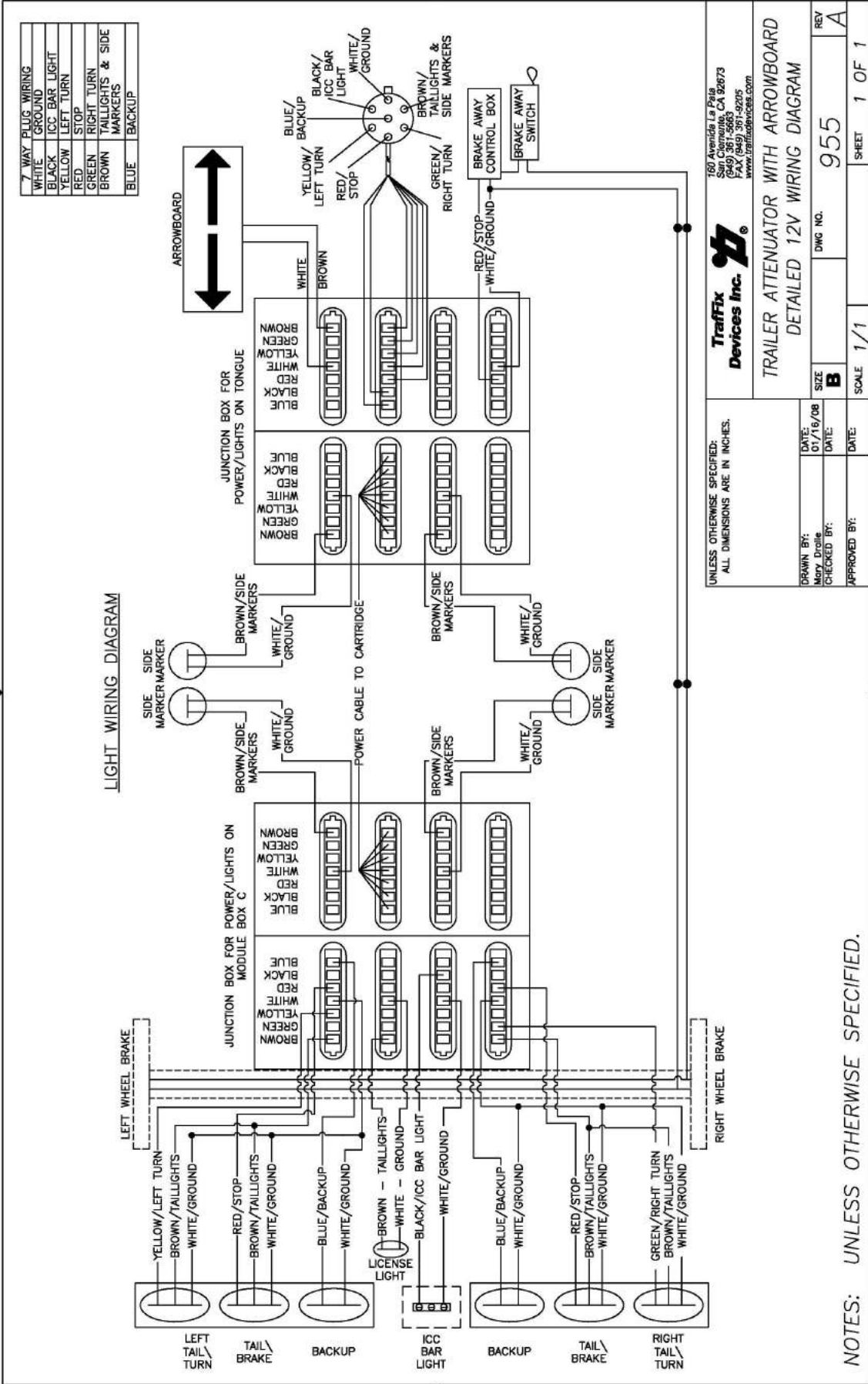

7 WAY PLUG WIRING	
WHITE	GROUND
BLACK	ICC BAR LIGHT
YELLOW	LEFT TURN
RED	STOP
GREEN	RIGHT TURN
BROWN	TAILLIGHTS & SIDE MARKERS
BLUE	BACKUP

UNLESS OTHERWISE SPECIFIED:
ALL DIMENSIONS ARE IN INCHES.

Traffix Devices Inc.
160 Avenida La Paja
San Clemente, CA 92673
Tel: (949) 361-9205
Fax: (949) 361-9205
www.traffixdevices.com

**TRAILER ATTENUATOR WITH ARROWBOARD
DETAILED 12V WIRING DIAGRAM**

DRAWN BY:	DATE:	SIZE:	DWG NO.:	REV:
Mary D'Arcy	01/16/08	B	955	A
CHECKED BY:	DATE:	SCALE:	SHEET:	
		1/1	1 OF 1	

NOTES: UNLESS OTHERWISE SPECIFIED.

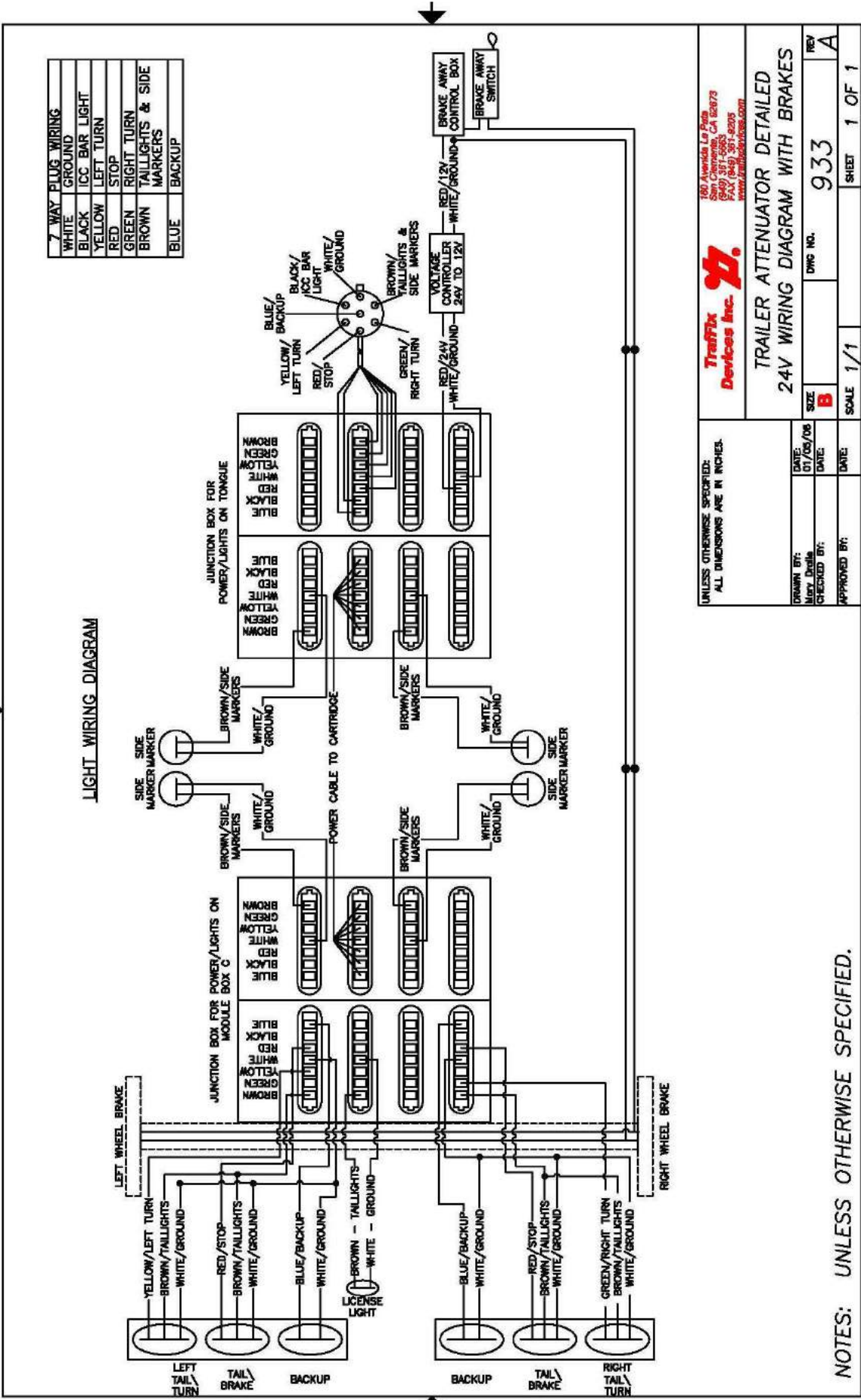

Traffix Devices Inc.
 160 Avenida La Pasa
 San Clemente, CA 92673
 (949) 381-5583
 Fax: (949) 381-5585
 www.traffixdevices.com

**TRAILER ATTENUATOR DETAILED
 24V WIRING DIAGRAM WITH BRAKES**

UNLESS OTHERWISE SPECIFIED: ALL DIMENSIONS ARE IN INCHES.	DATE: 01/05/08	SIZE: B	DWG NO.: 933	REV: A
DRAWN BY: Mary Dralls	DATE:	CHECKED BY:	SCALE: 1/1	SHEET 1 OF 1
APPROVED BY:	DATE:			

NOTES: UNLESS OTHERWISE SPECIFIED.

7 WAY PLUG WIRING
WHITE
BLACK
YELLOW
RED
GREEN
BROWN
BLUE

ARROWBOARD WIRING DIAGRAM

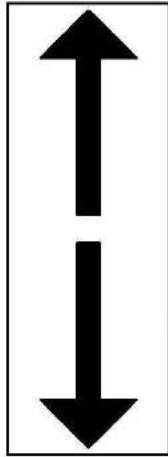

JUNCTION BOX FOR POWER/LIGHTS ON MODULE BOX C

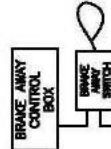
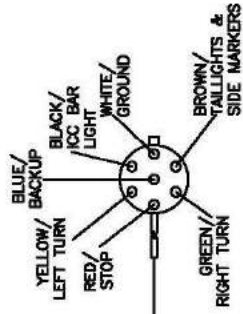
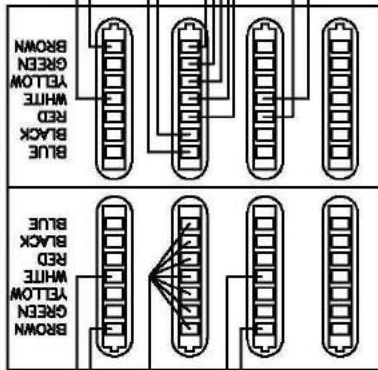

RED - STOP
WHITE - GROUND

UNLESS OTHERWISE SPECIFIED:
ALL DIMENSIONS ARE IN INCHES.

Traffix Devices Inc.
220 Calle Pionero
San Clemente, CA 92672
(949) 367-5553
FAX (949) 367-9225
TRAFFIXDEVICES.COM

**TRAILER ATTENUATOR WITH
ARROWBOARD WIRING DIAGRAM**

DRAWN BY: Mey. DeMa	DATE: 11/30/07	SIZE B	DWG NO. 940	REV —
CHECKED BY:	DATE:	APPROVED BY:	DATE:	SCALE 1/1

NOTES: UNLESS OTHERWISE SPECIFIED.

SHEET 1 OF 1

TA Limited Warranty

TraFFix Devices warrants to the purchaser that the Scorpion II Trailer Attenuator (TA) is free from any defects in materials and workmanship. If this product proves to be defective in material or workmanship during the period of this warranty, TraFFix Devices will repair or replace, at its option, the defective product free of charge. The period of this warranty is the one year period beginning from the date the purchaser puts the unit into service or one year from the date of purchase.

To obtain warranty service, the purchaser or distributor must first fill out a warranty authorization form and email same to TraFFix Devices to have our technical services department evaluate the problem and recommend repair procedures. **TraFFix Devices will then issue a signed warranty work approval form** to authorize the distributor or customer to repair or replace any items, which TraFFix Devices deems to have been defective. All replacement parts claimed to be defective will be invoiced at the time of shipment, and upon receipt and evaluation a credit memo will be issued.

This warranty does not extend to any failure of the Scorpion II TA caused by misuse, abuse or material alteration of this product, or any negligence in connection with the installation, service, or use of this product. For the correct installation, service, or use of this product refer to the installation manual, the operator's deployment instructions, and the operator's checklist.

Warranty Authorization Form

Company Name _____

Address _____

Phone/E-Mail _____

Name of Customer _____

Date _____

Serial number of TA near controller outlet: _____

List part numbers of replacement or repair items:

9. Describe the problem and reason for failure: _____

10. Email this form with any pictures. Then phone TraFFix Devices technical services.

Phone: (949) 361-5663

E-mail: orders@traffixdevices.com

Important Contact Information

Corporate Office

Traffix Devices, Inc.

160 Avenida La Pata
San Clemente, CA, 92673
USA

Email info@traffixdevices.com
Telephone 949.361.5663
Fax 949.573.9250

International Sales

Brent Kulp

Email bkulp@traffixdevices.com
Telephone 949.361.5663
Fax 949.573.9264

Larry Hudoff

Email lhudoff@traffixdevices.com
Telephone 954.997.9997
Fax 949.325.6059

Attenuator Product Specialist

Dave Evans

Email devans@traffixdevices.com
Telephone 949.449.7066

Northeast Territory

VA, WV, DE, MD, DC, NJ, NY, PA, CT,
MA, RI, NH, VT, ME

Mike Herlehy

Email mherlehy@traffixdevices.com
Telephone 585.267.9970
Fax 949.573.9239

Midwest Territory

OH, MI, IN, KY, IL, WI, MN, ND, SD, IA, MO

Dave Lindquist

Email dlindquist@traffixdevices.com
Telephone 630.605.1273
Fax 949.573.9240

Northwest Territory

MT, UT, ID, WA, OR, NV, CO, WY

Cary LeMonds

Email clemonds@traffixdevices.com
Telephone 801.979.7099
Fax 949.573.9290

Southwest Territory

TX, OK, KS, NE, NM, AR, LA

John Gense

Email jgense@traffixdevices.com
Telephone 214.704.1476
Fax 949.573.9291

Western Territory

CA, HI, AK, AZ

Rob Snell

Email rsnell@traffixdevices.com
Telephone 949.350.7048
Fax 949.573.9267

Southeast Territory

TN, NC, SC, GA, MS, AL, FL

Larry Hudoff

Email lhudoff@traffixdevices.com
Telephone 770.778.8281
Fax 949.325.6059



*160 Ave. La Pata
San Clemente, California 92673
(949) 361-5663
FAX (949) 361-9205
www.traffixdevices.com*

Distributed By: