

Lo-Ro[®] Water Cable Barrier Installation Procedure Manual

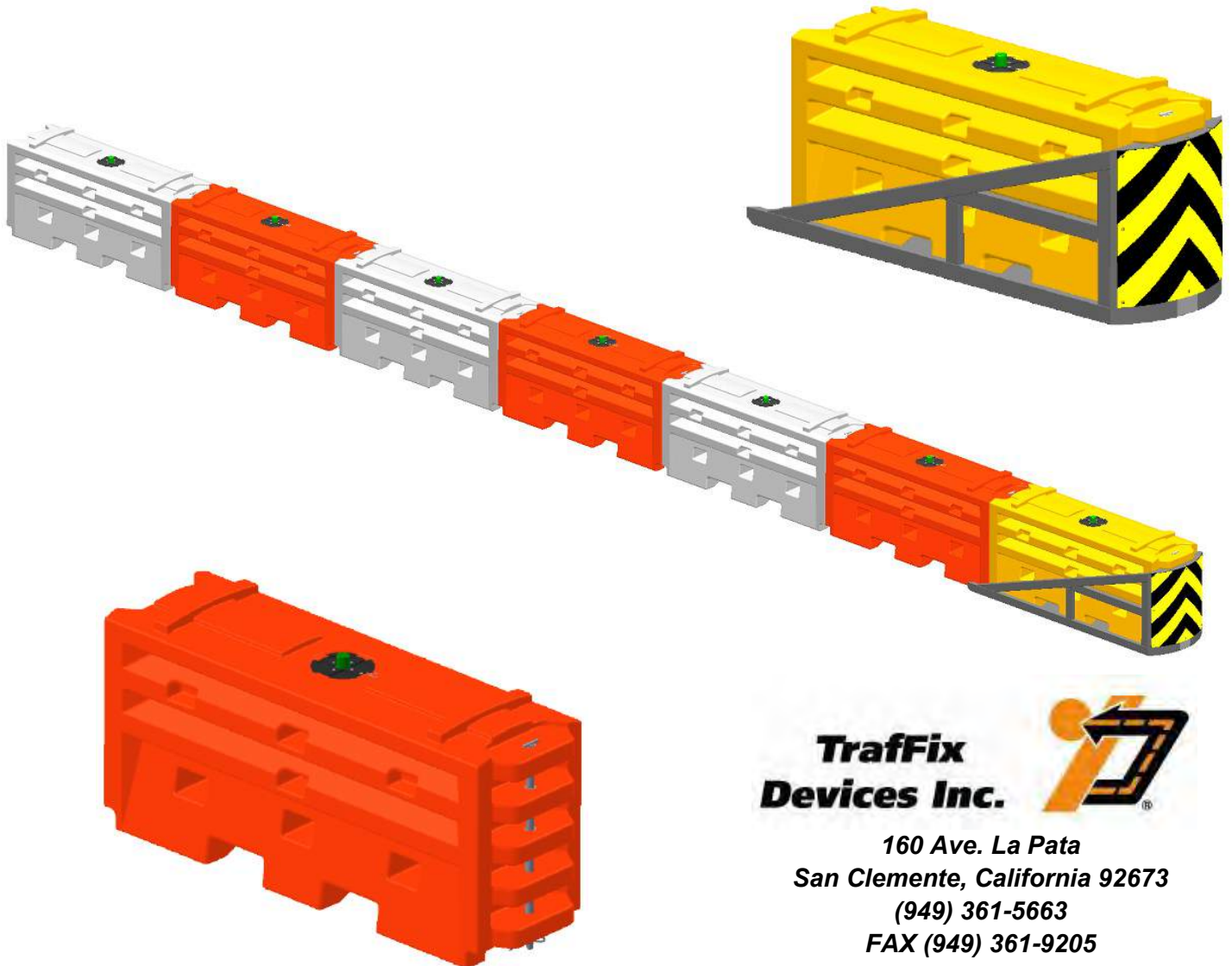

160 Ave. La Pata
San Clemente, California 92673
(949) 361-5663
FAX (949) 361-9205
www.traffixdevices.com

P/N 45036M-01Revision B (Dated 02/12/2020)

Table of Contents

IMPORTANT:

Read and understand ALL installation instructions before attempting to install the Lo-Ro[®] Water Cable Barrier.

	Page
Limitations and Warnings.....	1
Safety Precautions.....	2
System Overview/Product Overview and Function.....	3
Product Components and General Specifications.....	4
Maintenance and Repair	8
Water Freezing Prevention	10
Tools and Equipment for Assembly and Installation	11
SLED Lo-Ro End Treatment to Lo-Ro WCB Installation.....	12
Installing SLED Lo-Ro Nose Sheeting.....	19
Appendix A: Traffix Lo-Ro Water Cable Barrier Specifications	20
Appendix B: Traffix Lo-Ro SLED Specifications.....	23
Appendix C: Lo-Ro Limited Warranty	26
Appendix D: Regional Sales Managers, Key Contacts, and Customer Service	28
Notes	29

160 Ave. La Pata
San Clemente, California 92673
(949) 361-5663
FAX (949) 361-9205
www.traffixdevices.com

Limitations and Warnings

TraFFix Devices Inc. (TDI), in compliance with the Manual for Assessing Safety Hardware (MASH) recommended procedures for the Safety Performance of Highway Features. TDI contracts with ISO accredited testing facilities to conduct crash tests, evaluation of tests, and submittal of results to the Federal Highway Administration for Eligibility for Federal-Aid Reimbursement. Lo-Ro Water Cable Barrier (WCB) was tested to meet the safety evaluation guidelines of MASH. The Lo-Ro WCB has been tested at TL-2 (44 mph/ 70 km/hr) impact conditions. These tests are intended to evaluate product performance by simulating those impacts outlined by MASH involving a range of vehicles on the roadways, from cars with an approx. weight of 2425 lbs. [1100 kg] to trucks with an approx. weight of 5004 lbs. [2270 kg]. The Lo-Ro WCB is a TL-2 tested device capable of decelerating and stopping the light and heavy weight vehicles ranging from 2425 lbs. [1100 kg] to 5004 lbs. [2270 kg] in accordance with the criteria of MASH. These specified tests are not intended to represent the systems performance when impacted by every vehicle type or every impact condition existing on the roadway. This system is tested only to the test matrix criteria of MASH. TraFFix Devices does not represent nor warrant that the results of these controlled tests show that vehicle impacts with the products in other conditions would necessarily avoid injury to person(s) or property. Impacts that exceed the system's specifications may not result in acceptable crash performance as outlined in MASH; relative to structural adequacy, occupant risk, and vehicle trajectory. TDI expressly disclaims any warrant or liability for injury or damage to person(s) or property resulting from any impact, collision, or harmful contact with products, other vehicles, or nearby hazards or objects by any vehicle, object or person, whether or not the products were installed by third parties. The Lo-Ro WCB is intended to be assembled, installed and maintained in accordance with specific State and Federal guidelines.

Safety Precautions

CAUTION



Before handling any Traffix Devices product always be sure to wear proper protective equipment including:



SAFETY EYEWEAR



HARDHAT



HEARING PROTECTION



STEEL TOE BOOTS



SAFETY VEST



GLOVES

System Overview

The Lo-Ro Water Cable Barrier (WCB) is a longitudinal barrier designed to contain, redirect, and shield vehicles from roadside obstacles while providing positive protection and separation between the traveling public and personnel in the work zone.

Crash Performance

The Lo-Ro WCB Modules are orange and white in color. Each Module has overall dimensions of approx. 6.3 ft. (1.9 m) (pin to pin) x 1.8 ft. (0.5 m) x 3.0 ft. (0.9 m) and weighs approximately 160 lbs. (72.5 kg) when empty and 1517 lbs. (688 kg) when filled.

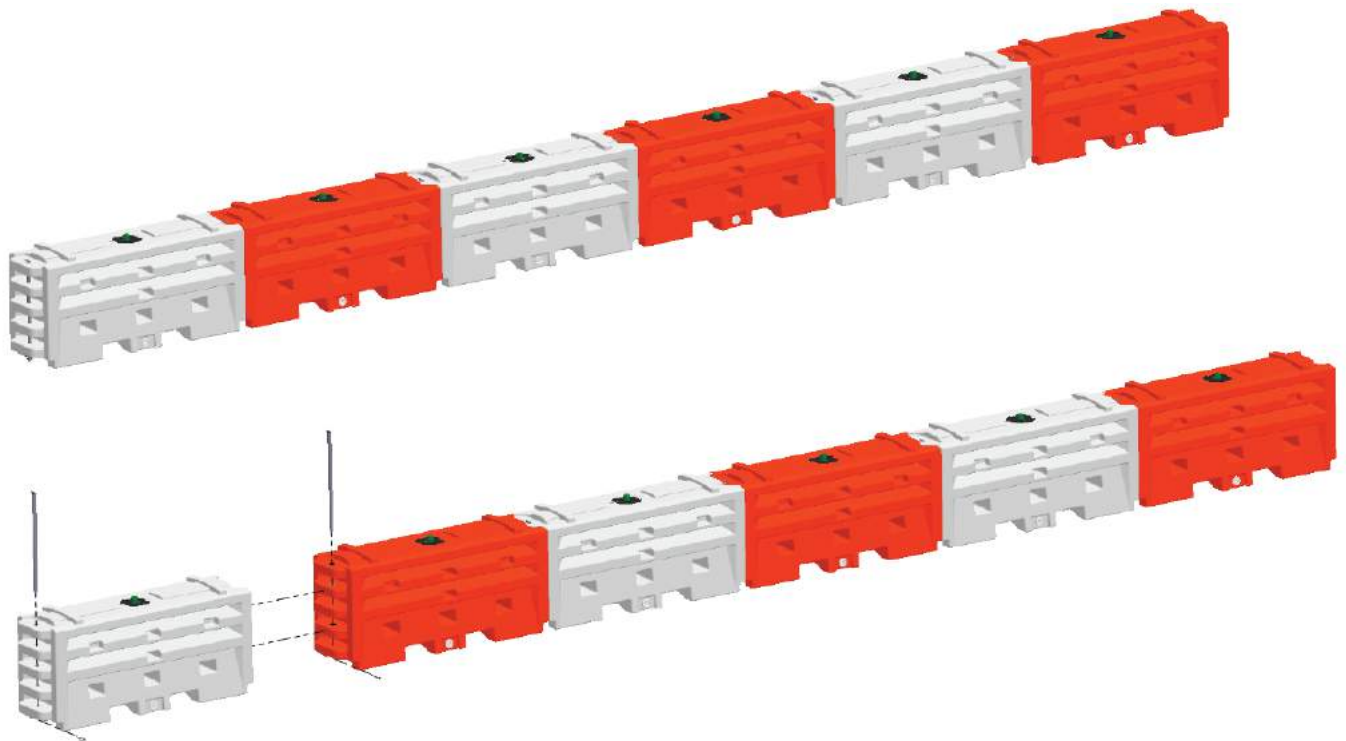

Figure 1: Traffix Devices Lo-Ro Water Cable Barrier Array.

Product Overview and Function

The Lo-Ro WCB is a water filled non-gating, redirective longitudinal barrier designed to contain, redirect, and shield vehicles from roadside obstacles and provides positive protection in the work zone. The Lo-Ro WCB consists of an array of water filled plastic modules to produce the desired energy attenuation characteristics to decelerate an impacting vehicle to meet TL-2 and TL-1 crashworthy requirements of MASH.

Additional Features:

- MASH TL-2 and TL-1 Tested
- Does not require any external steel for module assembly.
- Rotational molded plastic, modules are manufactured from specially formed material designed to be durable when handled and attenuate when impacted.
- Module sections up to ½” (14 mm) thick reduce nuisance hit damage and the potential for vandalism.

Product Components and General Specifications

Module Specifications

All Lo-Ro WCB Modules are Orange and White in color and have an outer shell made from energy attenuating plastic. The modules will collapse and rupture when impacted and disperse the contained water. The modules will not crack or corrode when left on the job site or stored for long periods of time.

Overall Dimensions:

Width: 22.5" [571 mm]

Height: 36" [914 mm]

Length: 75.75" [1924 mm] pin to pin

Weight:

Empty Weight: 160 lbs. [72.6 kg]

Filled Weight: 1517 lbs. [688 kg]

Fill Capacity:

Volume: 162.3 Gal [615 L]

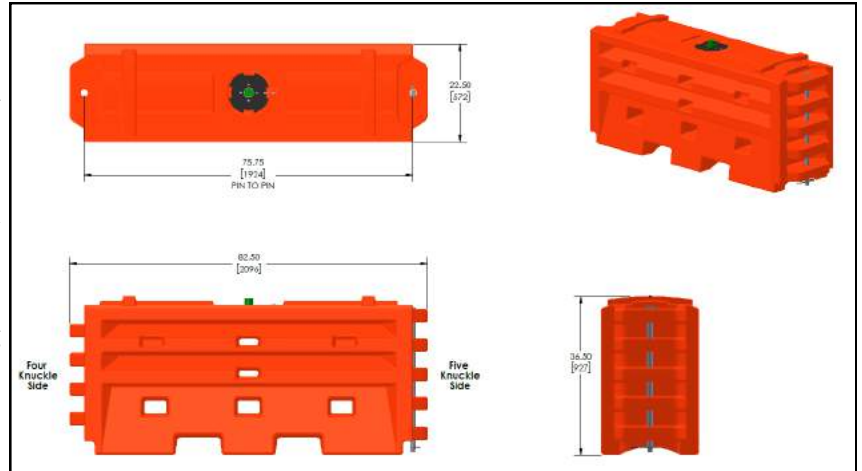

Figure 2: Lo-Ro WCB Module details.

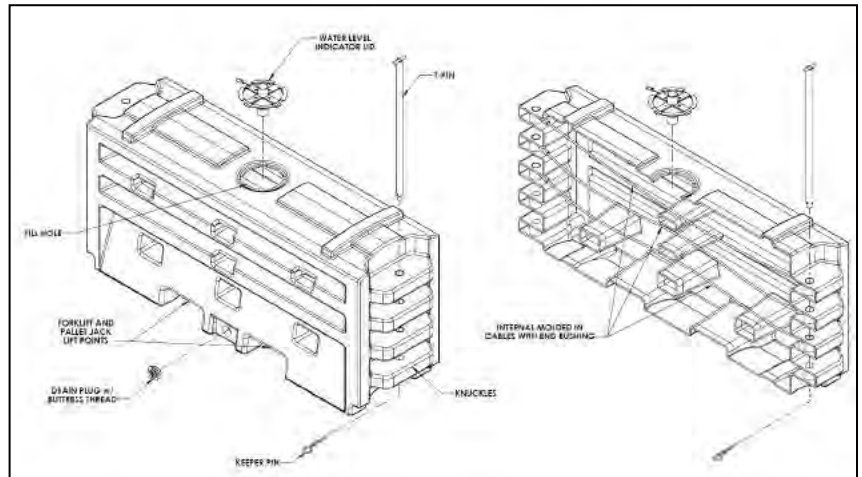

Figure 3: Lo-Ro WCB Module details cont'd.

Each module contains an eight inch diameter water fill-hole located on the top surface of each module section. This large diameter opening allows for easy access for water filling using a large diameter hose from a water tanker truck. Each module comes with a twist lock lid to cover the fill hole opening when the water filling process is complete. A water level indicator is designed into the twist lock lid.

For draining, a central drain hole is located at the bottom of each module. Each drain hole contains molded-in Buttress threads. The drain plug requires 1-1/2 turns to seal the plug preventing any water leaks. The molded-in Buttress threads eliminate the possibility of cross threading compared to standard threads used in a spin welded insert. Cracked spin welded inserts may require repair and are typically not reliable, leading to water leaks. The Lo-Ro WCB Modules, with molded in Buttress threads, eliminates both issues of cross threading and insert repair.

Two forklift pockets (slots) are designed into the modules, located at grade level, which can be used to insert forklift blades for moving the filled or unfilled Lo-Ro WCB Modules sections as needed. **The molded-in steel cables ARE NOT to be used for lifting the modules. Only the two forklift pockets (slots) should be used to lift the modules as identified in Figure 3.**

Lo-Ro WCB Installation

Foundation Requirements

The Lo-Ro WCB is free standing and does not require anchoring to the road surface and can be used on concrete, asphalt, gravel, and dirt surfaces.

Installation Instructions

The Lo-Ro WCB is delivered in two pieces: the first piece is the module with the twist lock fill cap and the buttress threaded drain plug installed. The second piece will be the steel T-Pin with the keeper pin installed.

Proper site planning will have identified the required quantity and placement of the Lo-Ro modules. The modules should be removed from the transport vehicle using safe lifting and movement procedures.

At the end of each module are interlocking knuckles. Within the knuckles are a series of vertical concentric holes as seen in Figure 4 below. When linking individual modules together, the knuckle holes are vertical aligned with the adjacent module. This creates a series of nine (9) knuckles interlocked together with a connecting T-Pin, which is inserted through the concentric holes. Located at the bottom of each T-Pin is a safety keeper pin which is inserted into the alignment hole at the bottom of each T-Pin as seen in Figure 4. The keeper pin must be inserted to finalize the installation on each module.

Once the modules have been properly interlocked, the modules are to be filled up with water. If the optional water level indicator is installed, ensure that the level indicator becomes fully raised. Since the water level indicator is built into the fill cap, care should be taken to ensure that the water level indicator is not damaged during the removal and re-installation process.

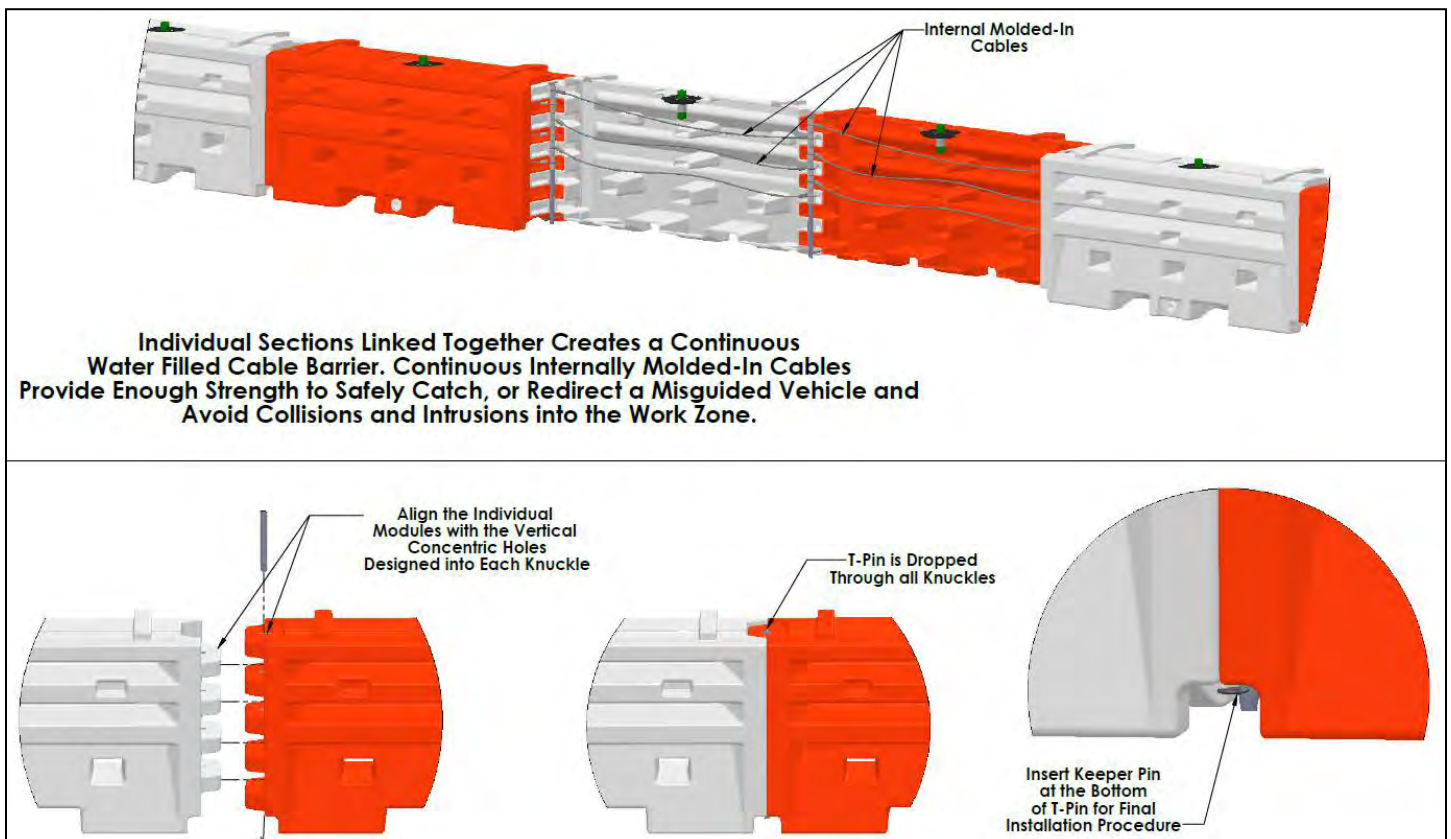

Figure 4: Installation Assembly Guide Diagram

Water Level Indicator Fill Cap

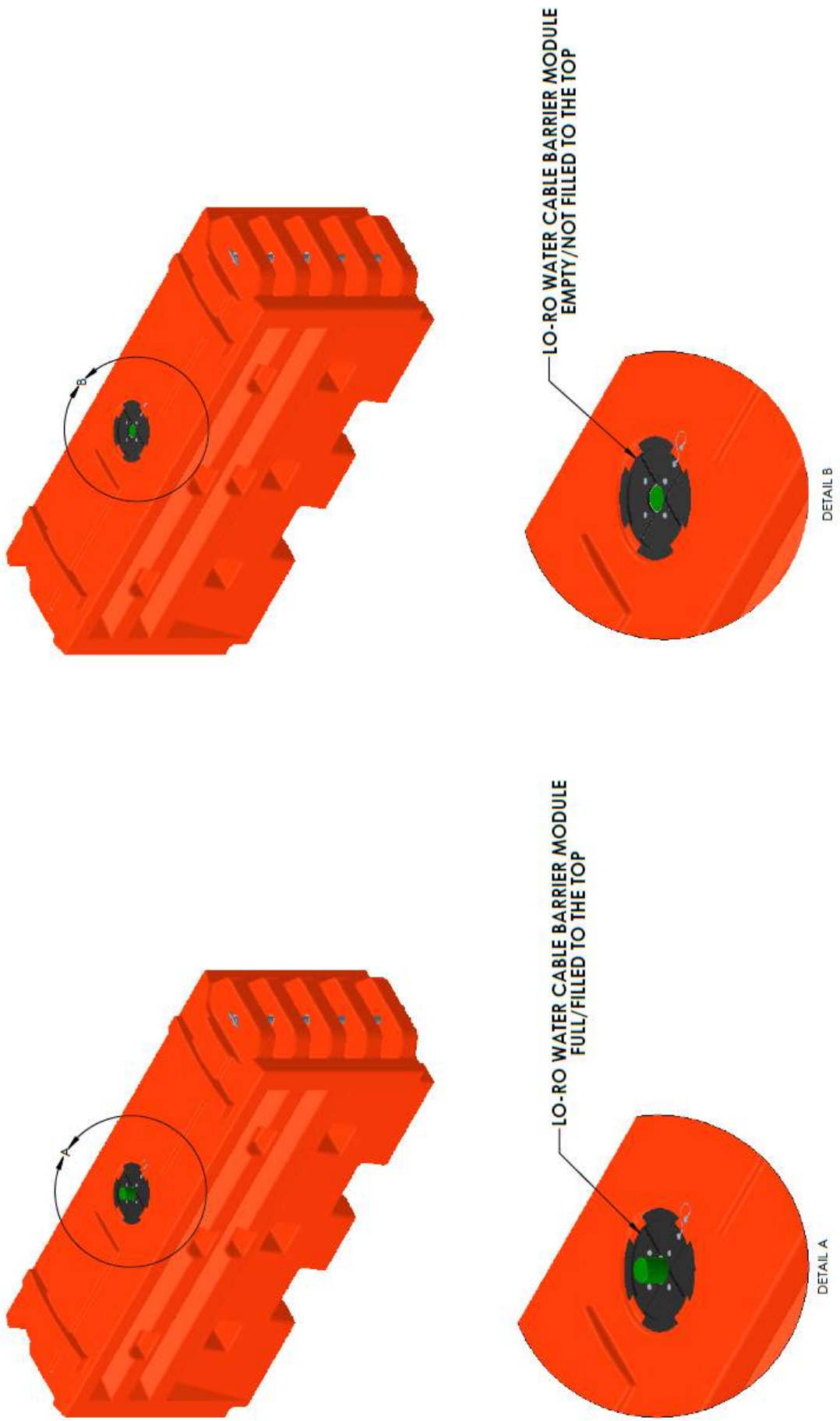

Figure 5: Traffix Lo-Ro WCB Module float cover.

Recommendations for Stacking

Modules can be stacked **ONLY** when empty and are not designed to be stacked on each other when filled. Stacked empty modules can be no more than three high as seen in Figure 6. Designed into the top surface of each module are stacking lugs which fit into recessed formed sections on the bottom surface of each module as seen in Figure 6. These stacking lugs interlock the modules preventing the wall from shifting during transport or storage. The stacking lugs should be used in conjunction with straps to securely hold the entire stacked pieces together. For additional support, a long T-pin can be inserted into the knuckles to secure the modules as seen in Figure 6.

FOR STORAGE, STACK EMPTY ONLY - DO NOT STACK WHEN FILLED.
STACK ONLY THREE HIGH - MAXIMUM.
FOR STABILITY, A VERTICAL LOCK PIN CAN BE USED
TO VERTICALLY INTERLOCK SECTIONS TOGETHER.

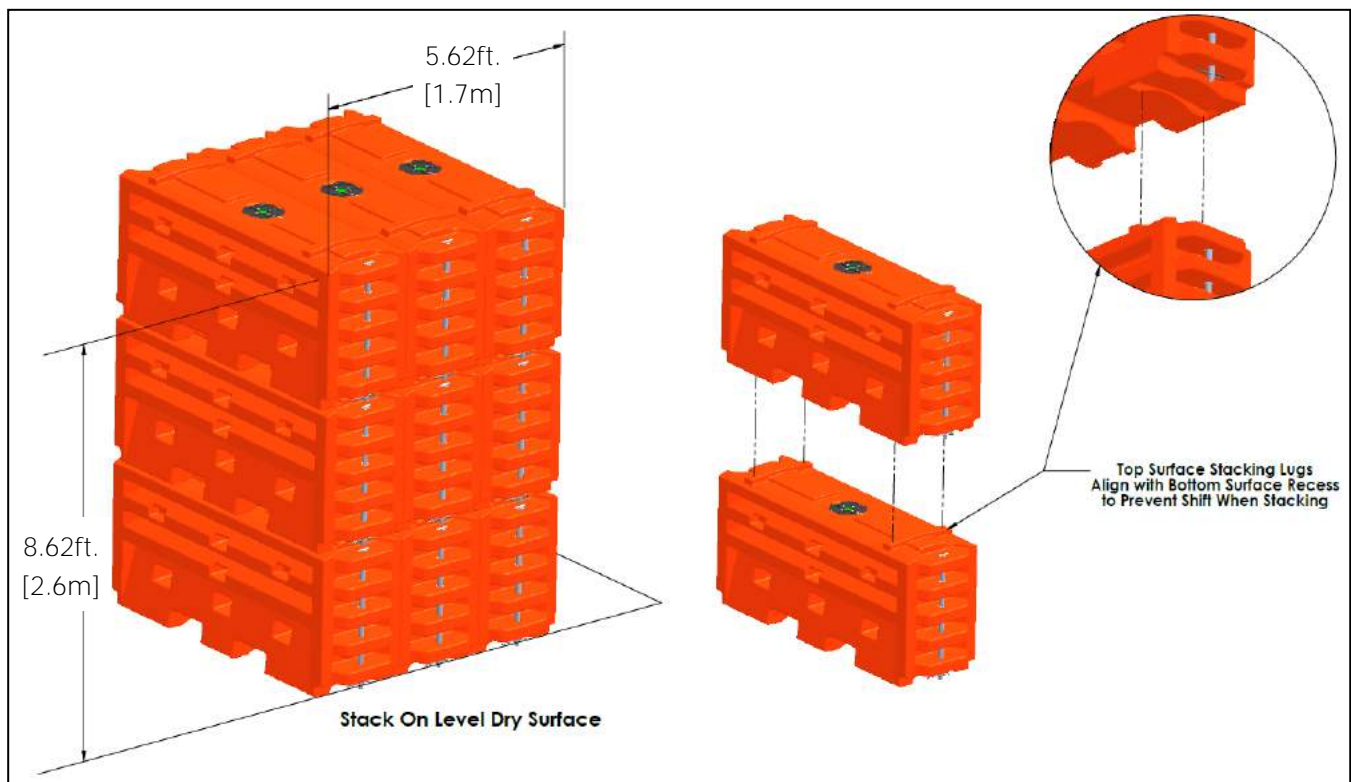

Figure 6: Module Stacking Diagram for Long Term Storage Requirements

SAFETY PRECAUTIONS WHEN HANDLING THE LO-RO WCB MODULES

Do not drive with two (2) or more filled modules on a forklift. If maneuvering filled modules is necessary using a forklift, only move filled modules one (1) at a time. If the modules are empty, a maximum of three (3) stacked modules may be moved using a forklift. NEVER stack modules when filled, and NEVER stand underneath or in front of the forklift when handling the modules with a forklift, as modules may fall.

Maintenance and Repair

There are no scheduled maintenance requirements for the Traffix Lo-Ro WCB. There should be periodic checking of the water level to insure that it is filled to the proper level. The Lo-Ro WCB is not fully effective unless each section is filled. If the optional water level indicator is installed, a visual inspection can be made while driving by, otherwise the fill cap should be removed for inspection. The Lo-Ro and SLED Lo-Ro can be identified by the molded in ID plates seen below. The manufacture date is also molded into the knuckle of the Lo-Ro modules.



In a major impact, a severely damaged the damaged Lo-Ro modules should be removed and replaced. There may be leaking section that can be repaired following the steps on the following page.

Patching leaks (holes or cracks) in the Traffix Lo-Ro plastic should be done on completely dry surfaces free of dirt and grease. In addition, any paint or added finish beyond the factory smooth plastic surface should be removed.

Plastic welding and welding patches onto the surface is the most common method for repairing leaking section of the Lo-Ro WCB. A plastic repair kit can be obtained from Traffix Devices. The plastic patch and welding rod are made from the same material as the Lo-Ro WCB. A small butane or propane torch is used for applying heat to the plastic rod. The rod should be melted to the patch and the wall surface in order to create a bonded patch. Temperature for bonding the plastic is 500-550°F (260-290°C). The torch head should be held 5-13 mm away from the weld surface. Care should be taken when applying heat to plastic to insure that the melting occurs only as desired.

NOTE: Repairing a crack or hole DOES NOT return the plastic to its original strength, although most repairs are sufficient to insure a water tight section. Monitoring of the repair should be done for a short period after filling to insure that the repair has been done properly. If leaks cannot be prevented, the section should be replaced.

In addition, if there has been an impact, the T-Pin may be difficult to remove for wall realignment since some section have been compressed. A forklift will facilitate wall realignment if necessary, without removing the T-pins or to relieve the force on the T-pins.

NOTE: When moving full modules, use the fork lift pockets located at the bottom of the wall.

Maintenance and Repair

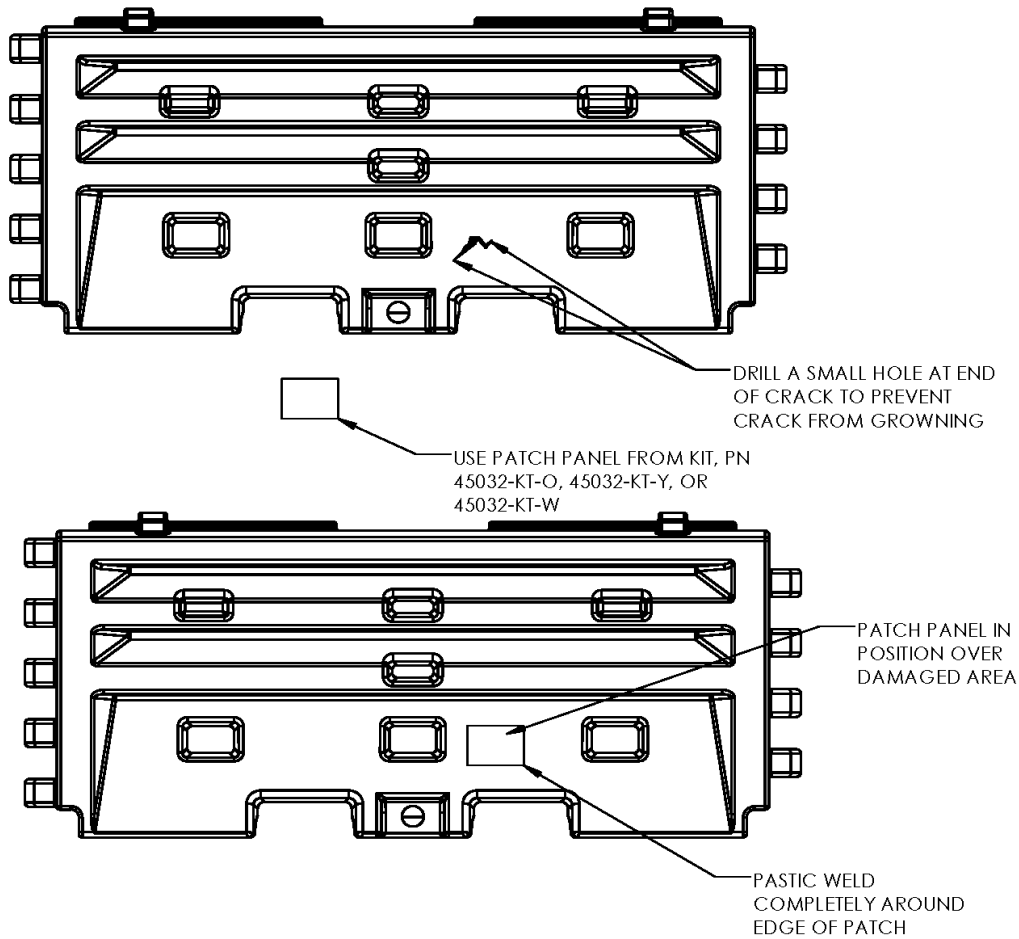

Dismantling

If redeployment to another near-by site is required, a decision should be made as to whether draining of the sections is required. If the correct equipment is available, draining may not be necessary, but extreme care must be made when moving the sections because of their weight. The correct equipment would be a forklift and appropriate transport vehicle. If the Lo-Ro WCB is going to be stored for a period of time or if the correct equipment is not available, the sections should be drained by removing the drain plug or pumping the water out of the fill hole location.

Recycling

Once a module is out of commission the modules can be disassembled and recycled. The modules are made from HDPE and can be recycled once the internal wire ropes are removed. The steel components can also be recycled.

Water Freezing Prevention

In freezing weather conditions, do not allow the water in the Lo-Ro Water Cable Barrier (WCB) modules to freeze to a solid mass of ice. If the temperature at the Lo-Ro WCB array site is expected to be at or below the freezing point of water 32° F [0°C], it is recommended that an additive be used to prevent the water in the Lo-Ro WCB modules from freezing. See Table 1 on pg. 11.

-Common additives used to prevent water freezing currently used in work zone devices under the same category as the Lo-Ro WCB Modules.

SALT (Sodium Chloride)

20% mixture by weight

Reduces freezing down to 0° F [-18° C].

Corrosive to inadequately protected steel components (Galvanizing adequately prevents corrosion)

Recommended - premix before filling

Prevent spilling since solution is harmful to vegetation, soils, and wildlife. Draining should be done in an acceptable area.

CALCIUM CHLORIDE

35% mixture by weight

Reduces Freezing down to 20° F [-6.6 °C].

Corrosive to thin zinc plated components

Corrosive to inadequately protected steel components (Galvanizing adequately prevents corrosion)

High tendency to stay on road surface resulting in slick road surface.

High level of heat created when mixing. It is recommended that pre-mixing is done before filling.

Prevent spilling since solution is harmful to vegetation, soils, and wildlife. Draining should be done in an acceptable area.

ETHYLENE/PROPYLENE GLYCOL

50% mixture by volume

Reduces water freezing to 0° F [-18° C].

High tendency to stay on road surface resulting in slick road surface.

Prevent spilling since solution is harmful to vegetation, soils, and wildlife. Draining should be done in an acceptable area.

LIQUID CMA (Calcium Magnesium Acetate)

25% mixture by volume

Reduces water freezing to 0° F [-18° C].

Has a low environmental impact.

LIQUID POTASSIUM ACETATE

60% mixture by volume

Reduces water freezing to 20° F [-6.6° C]

Low corrosive characteristics and has a low environmental impact.

Table 1- Recommended water freezing prevention chart solution comparison.

Additive	Environmental Impact	Cost Rating	Protection Temp	Mix Solution Ratio
Salt (Sodium Chloride)	Harmful	Low	0 °F [-18 ° C]	20% by weight
Calcium Chloride	Harmful	Medium	20 °F [-6.6 ° C]	35% by weight
Ethylene/Propylene Glycol	Dangerous	High	0 °F [-18 ° C]	50% by volume
Liquid CMA	Non-Toxic	High	0 °F [-18 ° C]	25% by volume
Liquid Potassium Acetate	Non-Toxic	High	20 °F [-6.6 ° C]	60% by volume

Tools and Equipment for Assembly and Installation

This list of tools is a recommendation. The actual tools required will depend on site conditions for the assembly and installation. Personal protective equipment should always be used during assembly and installation. Safety eyewear, steel toe boots, hard hat and gloves are recommended as protection devices for the installer's safety.

Documents:

Before the assembly and installation of this product, it is recommended that the complete manufactures manual and drawing package be reviewed for clarity of the installation.

Tools:

- Pry/Breaker Bars
- Sledge and Ball Peen Hammers
- Chalk Line
- Tape Measure

Optional Tools:

Tools that may also be needed: Grinder, Hacksaw, or Torch

SLED Lo-Ro End Treatment Installation to Lo-Ro Water Cable Barrier

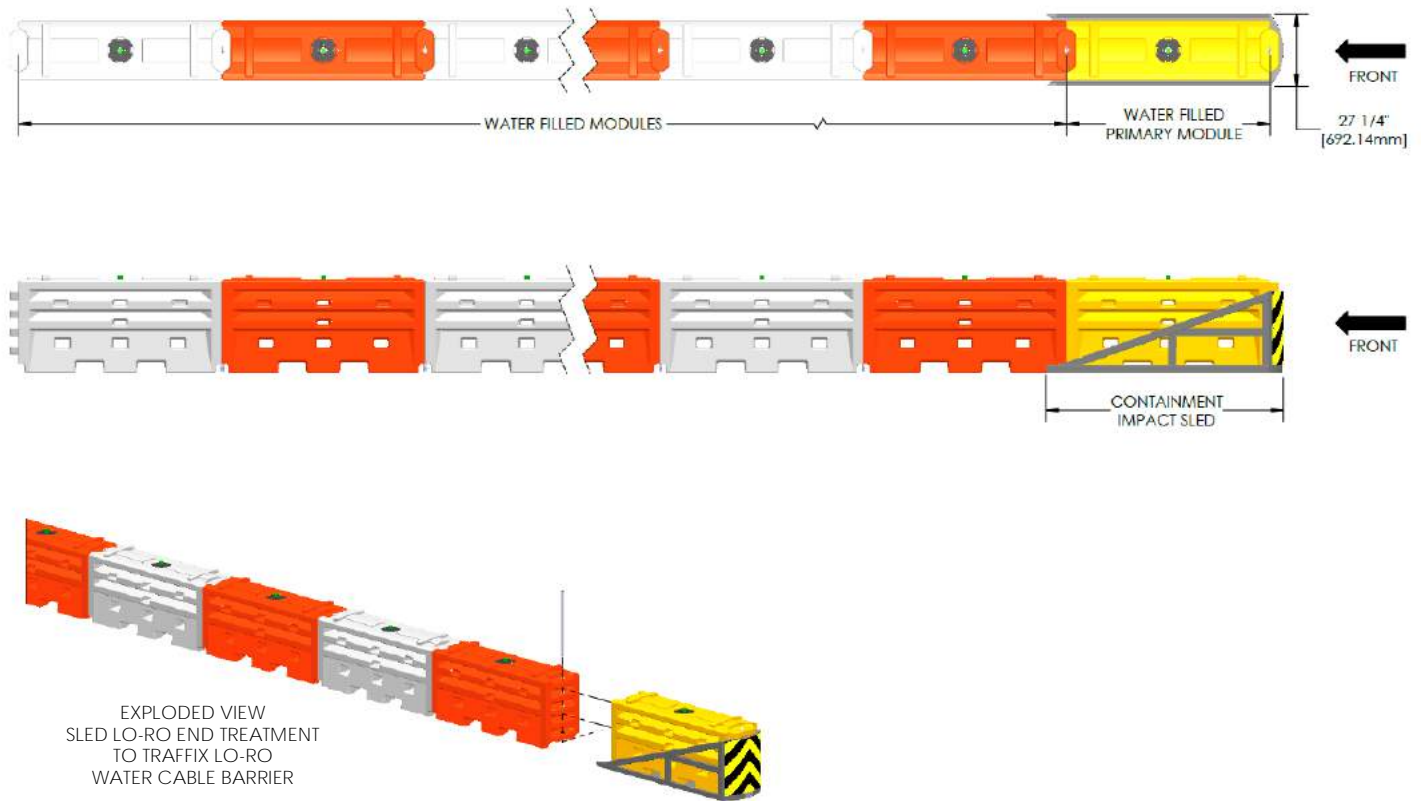
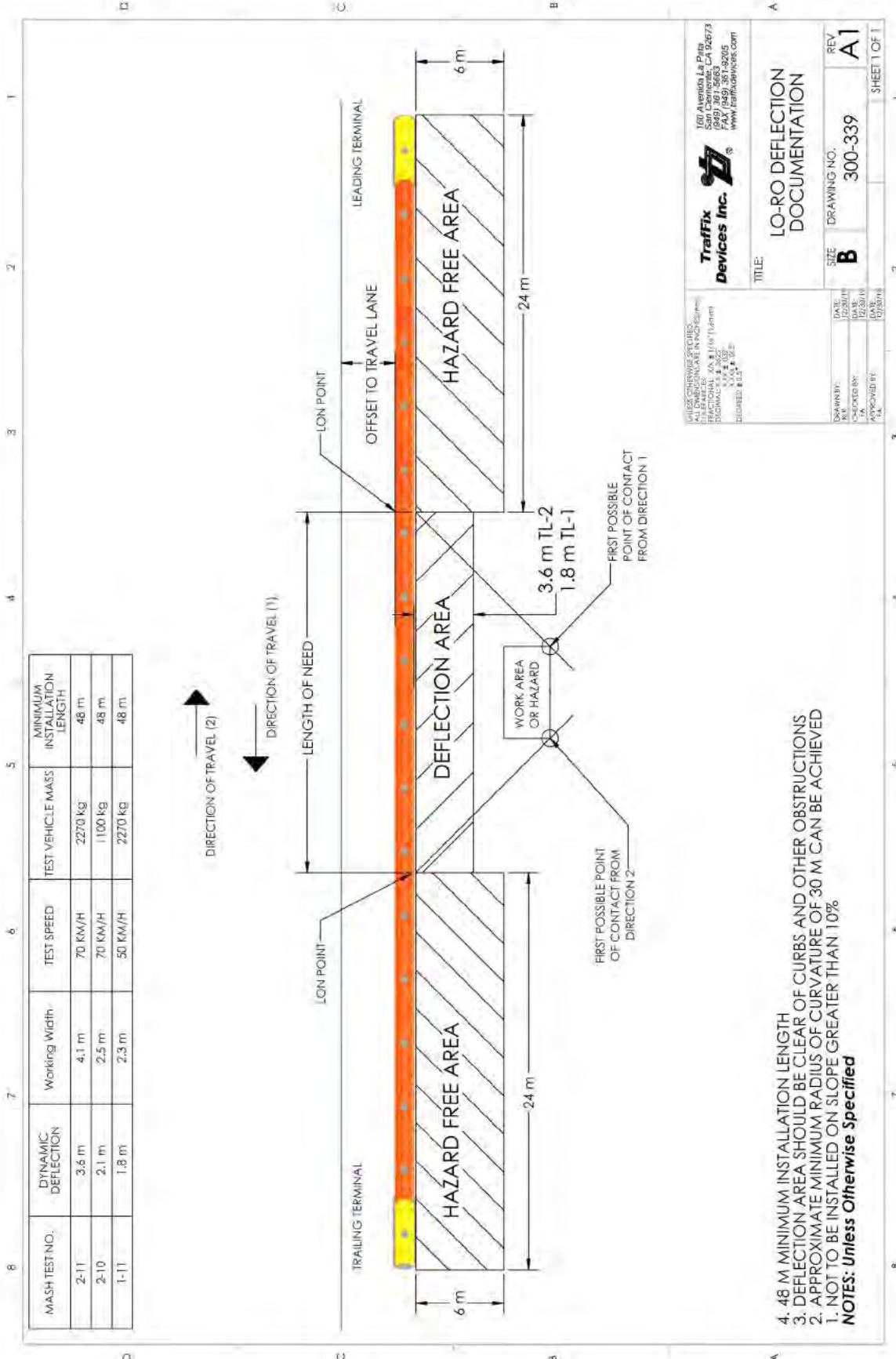

Figure 7: General specifications of installed TL-2 and TL-1 SLED Lo-Ro End Treatment system to Lo-Ro WCB Array.

Installation procedure to begin on next page

Design Guidance



Traffix Devices Inc.

160 Avenida La Piedra
San Dimas, CA 92673
Tel: (951) 960-6663
Fax: (951) 361-9205
www.traffixdevices.com

TITLE: LO-RO DEFLECTION DOCUMENTATION

SIZE: B **DRAWING NO.:** 300-339 **REV:** A1

DATE	BY	DATE	BY

UNLESS OTHERWISE SPECIFIED:
ALL DIMENSIONS ARE IN METERS
FRACTIONAL SIZES SHALL BE IN METERS
TOLERANCES UNLESS OTHERWISE SPECIFIED:
DIMENSIONS IN MILLIMETERS
DECIMALS: ±0.25

Containment Impact Sled

The Containment Impact Sled (CIS) is attached to the front full module (Figure 8). The steel CIS is hot-dip galvanized to minimize the effects of corrosion. Upon impact, the CIS slides rearward containing the ruptured modules.

Overall Dimensions:

Width: 27" [686 mm]

Height: 36" [914 mm]

Length: 88.75" [2254 mm]

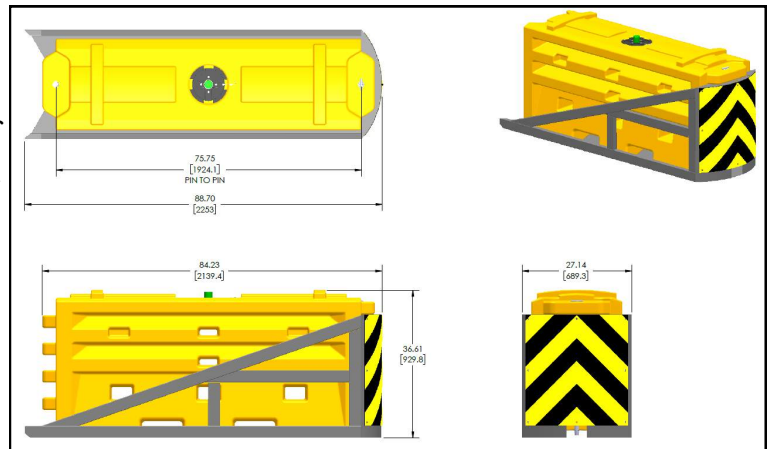

Figure 8: SLED Lo-Ro End Treatment CIS Filled Module.

Total Weight:

Weight: Approx. 1700 lbs. [771 kg]

The CIS is a tube frame design with a curved front cap and a flat steel bottom. The CIS is pinned onto a Fill Module with a vertical T-pin that drops through a series of the concentric holes in the Module knuckles which align with the CIS pin hole as shown in Figure 9.

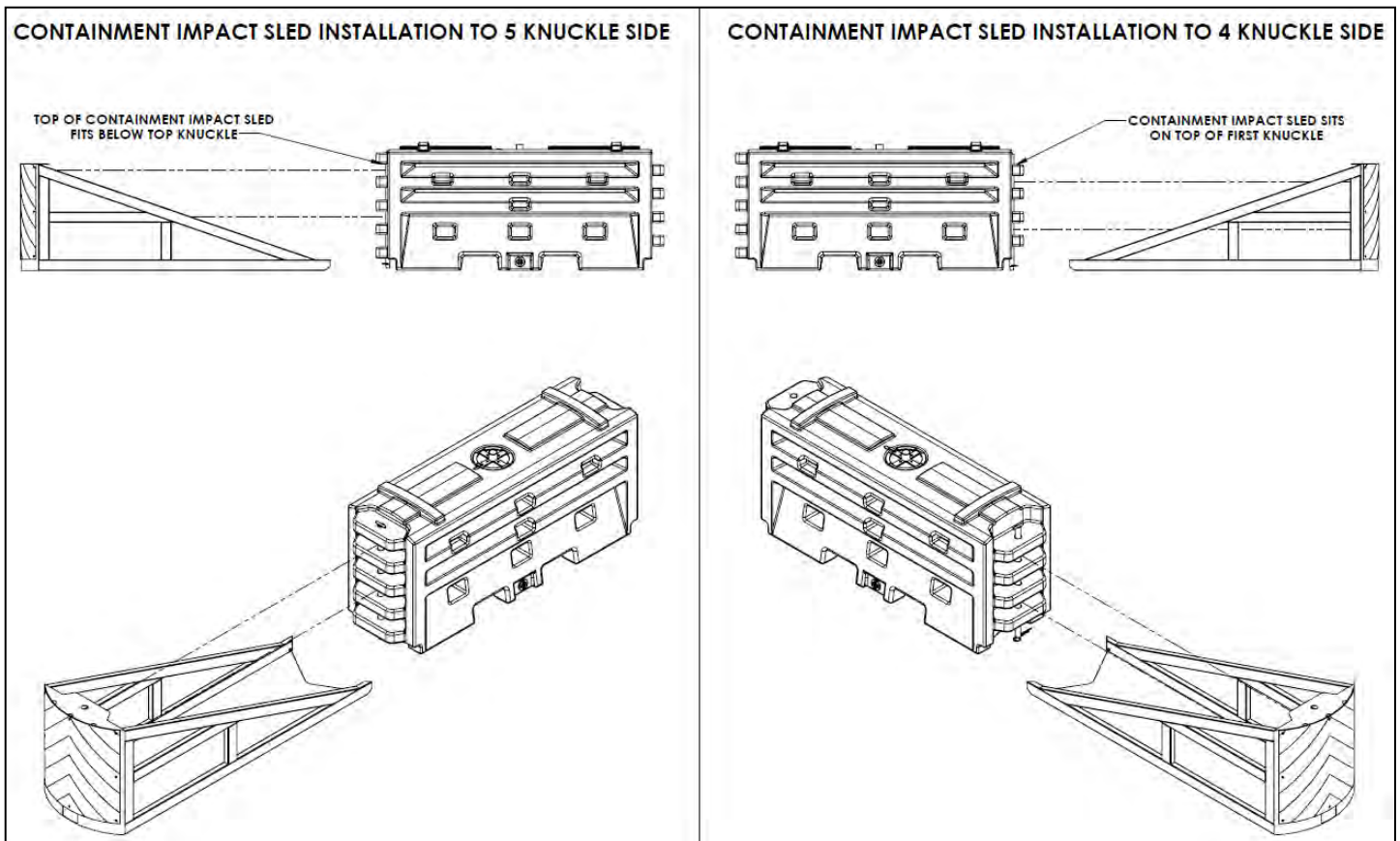
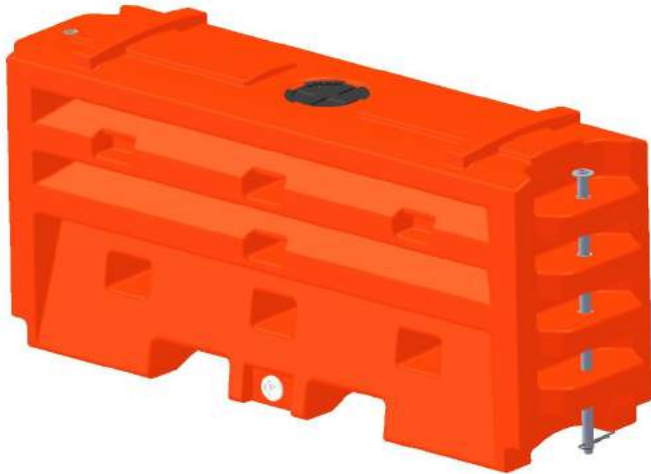

Figure 9: SLED Lo-Ro End Treatment CIS Frame installation to both ends of a Lo-Ro fill module.

Lo-Ro Water Cable Barrier
Parts Checklist



P/N 45036M-O

36" Lo-Ro Barrier Orange MASH TL-2
w/ Pin, Fill Lid, and Plug

Qty. 1

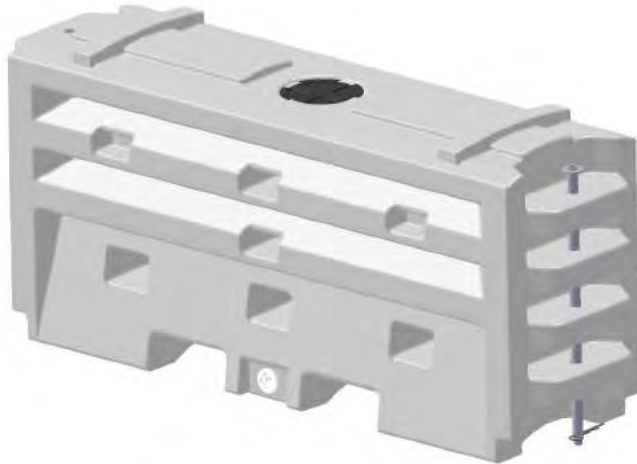

P/N 45036M-W

36" Lo-Ro Barrier White MASH TL-2
w/ Pin, Fill Lid, and Plug

Qty. 1



**Keeper Pin (45032-PN)*

P/N 45036-CPGAL-01

Washer Top Interlocking Pin

Qty. 1/Module



P/N 45033-RC-B

Water Wall Drain Plug

Qty. 1/Module

Lo-Ro Water Cable Barrier Parts Checklist



P/N 45036M-Y-CIS

Containment Impact Sled (CIS) Steel Frame w/ Nose Sheeting, Yellow Lo-Ro Fill Module & T-Pin

Qty. 1

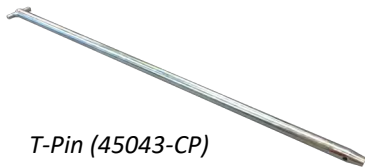

T-Pin (45043-CP)



Keeper Pin (45032-PN)



P/N 45030A-AV-Y4

SLED Lo-Ro CIS w/ Directional Indicator Avery 4" Refl. Sheeting

Qty. 1



P/N 18009-BLK

Fill Cap, Standard WW Lid

Qty. 1/Module

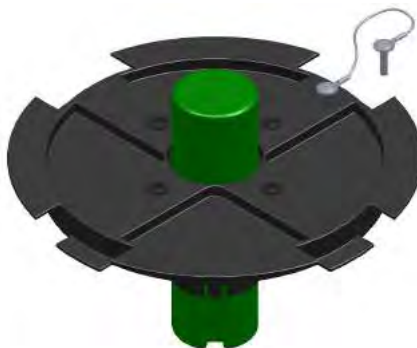

P/N 18009-B-I (Optional)

Float Fill Cap "Drive By"

Qty. 1/Module

Lo-Ro Water Cable Barrier
Parts Checklist

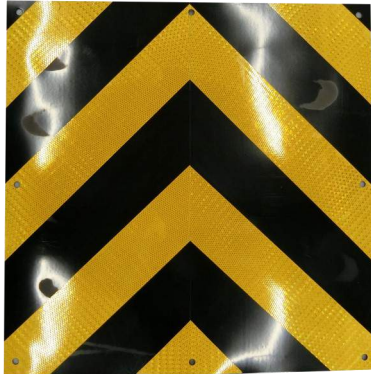

**Gore Point
Sheeting
(Front Side)**

P/N 45044-S-AV-Y4

Sheeting Set, SLED End Treatment

Qty. 1



**Left Hand Nose
Sheeting
(Back Side)**



**Right Hand Nose
Sheeting
(Back Side)**

Installing the Containment Impact Sled (CIS) to Lo-Ro Water Cable Barrier Array

Step 1:

Push the pre-assembled SLED Lo-Ro CIS up to the front most Orange/White Lo-Ro Water Cable Barrier Module as shown in the figure below. Determine that the Module knuckles will mate up the 4 knuckle side with the 5 knuckle side. If Module knuckles do not mate up, you will need to rotate the Yellow Fill Module within the CIS.

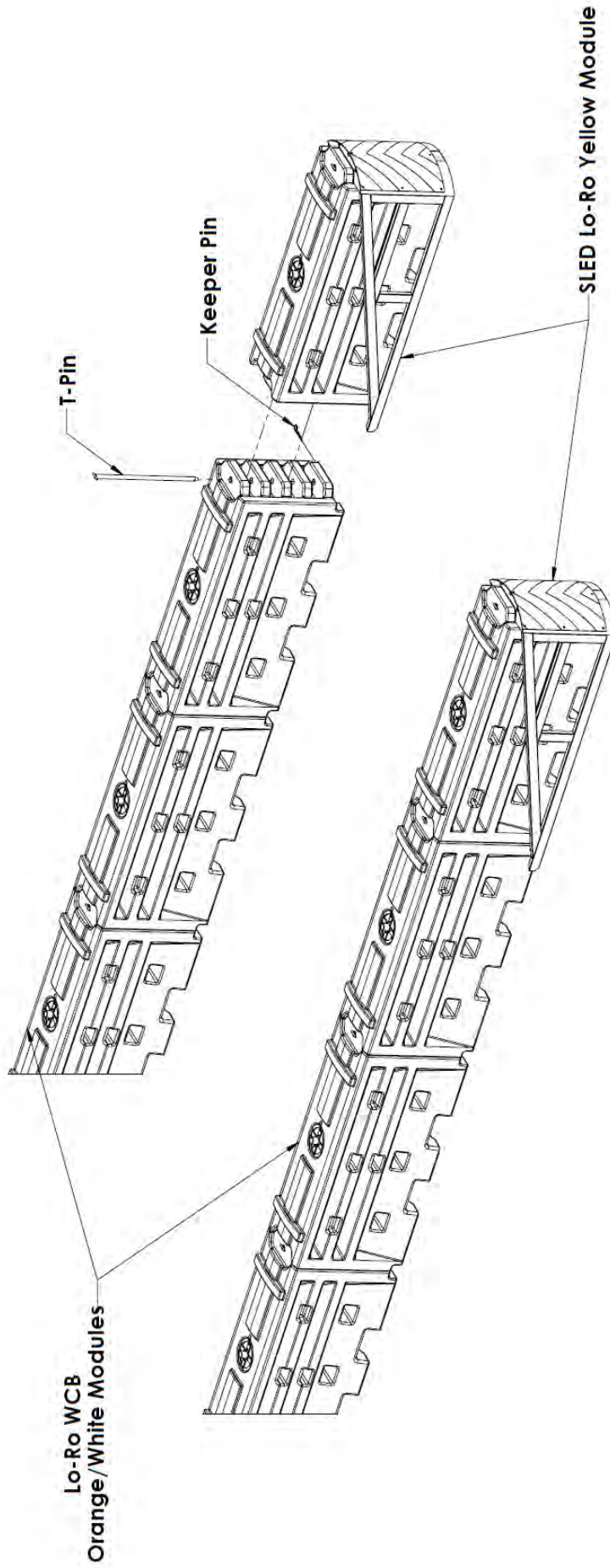

Installing SLED Lo-Ro Nose Sheeting

The SLED Lo-Ro nose sheeting has been provided as a way to customize for field use as seen in Figure 10. On Side A, the diagonal stripes can but used for Left Hand traffic flow or rotated 90° for Right Hand traffic flow. Turn the sheeting over and Side B is used for gore point traffic flow. Once the direction is determined, secure the sheeting to the nose with supplied screws.

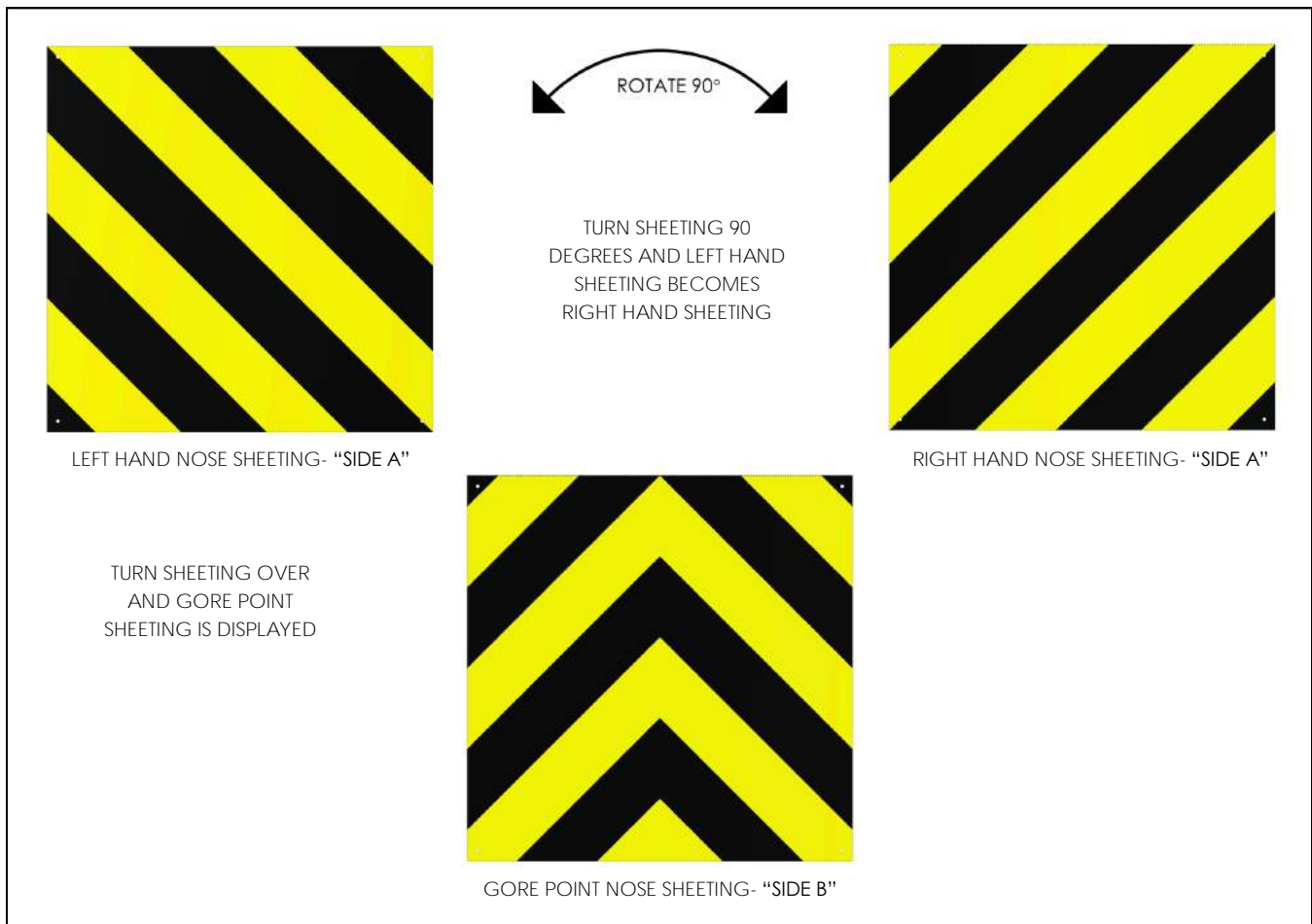

Figure 10: SLED Lo-Ro Nose Sheeting Installation



Appendix A:

TrafFix Lo-Ro

Water Cable Barrier

Specifications

160 Ave. La Pata
San Clemente, California 92673
(949) 361-5663
FAX (949) 361-9205
www.traffixdevices.com

TraFFix Devices Inc.
TraFFix Lo-Ro Water Cable Barrier
General Specifications

I. General

The Lo-Ro Water Cable Barrier (WCB) components, and subassemblies shall be designed and manufactured by TraFFix Devices Inc. (TDI)

Corporate Office San Clemente, California

II. System Description

The Lo-Ro WCB is a temporary water filled barrier designed and tested to the crashworthy requirements of MASH. The Lo-Ro WCB shall be installed where positive protection and positive separation is specified between the traveling public and personal in the construction work zone.

The Lo-Ro WCB shall be constructed from a series of individually linked modules. Each individual module shall consist of:

- Virgin polyethylene plastic, containing UV stabilizers and antioxidants molded to a triple faced saw tooth profile. The saw tooth ribbed surfaces shall be a flat profile to adhere reflective sheeting if required.
- The top surface shall contain two stacking lugs, which assemble into two recessed voids on the modules bottom surface. The stacking lugs shall restrain the modules to each other when vertically stacked for storage and shall minimize shifting during transport.
- The ends of each module shall be constructed with vertically aligned knuckles which interlock with those of adjacent modules and accept a steel connecting pin. The pin is retained after installation by a keeper pin.
- Each module shall contain three internal molded-in cables acting as a cable barrier when impacted. Each cable is connected to a steel bushing which is molded into the knuckle sections and is of appropriate diameter to meet design speeds of TL-2 impacts.
- The approximate dimensions, weight, and volume of each module shall be: 572 mm [22.5 in.] width x 914 mm [36.0 in.] height x 1924 mm [75.75 in] length (pin to pin). Empty weight 72.5 kg [160 lbs.], weight filled 688 kg [1,517 lbs.], water ballast 615 L [162.3 Gal]
- Modules shall be manufactured in orange, white or any other colors upon customer's request.
- Each module shall be manufactured with fork lift openings to allow for lifting when empty or full. Each module shall be manufactured with one 203.2 mm [8 in.] diameter twist lock fill lid and a 57.15 mm. [2.25 in] diameter molded-in Buttress threaded drain hole with a plug to allow quick water ballast draining. Optional water level indicator, available upon request.

III. Performance Criteria

The Lo-Ro WCB shall be tested and passed all crashworthy requirements of MASH for Test Level 2 (TL-2) impact conditions for 1100 kg [2425 lbs] and 2270 kg [5004 lbs] vehicles at impact speeds of 70 km/h [43.5 mph].

The Lo-Ro Barrier test results shall demonstrate a non-gating, re-directive characterizes or controlled penetration of the barrier when impacted at high impact angles of intrusion at the critical impact point. All occupant risk values shall not exceed the maximum allowable of 12.2 m/s for Occupant Impact Velocity (OIV) and 20.49 g's for Ridedown Acceleration (RA).

Maximum dynamic deflection at the point of impact shall not exceed 3.6 m [11.8 ft] when impacted at the design speed of 70 km/h (43.5 mph) utilizing the 2270 kg [5004 lbs] impact vehicle with an impact angle of 25°.

The Lo-Ro barrier shall be capable of preventing vehicle penetration, vaulting, under ride, and shall bring the impacting vehicle to a controlled stop in the vicinity of the impact area, or shall redirect the vehicle, while undergoing controlled lateral deflection.



Appendix B:

TrafFix Lo-Ro

SLED

Specifications

160 Ave. La Pata
San Clemente, California 92673
(949) 361-5663
FAX (949) 361-9205
www.traffixdevices.com

TraFFix Devices Inc.
TraFFix Lo-Ro Water Cable Barrier
General Specifications

I. General

The Lo-Ro SLED End Treatment System, components, and subassemblies shall be designed and manufactured by TraFFix Devices Inc. (TDI)

Corporate Office San Clemente, California

II. System Description

The Lo-Ro SLED is a temporary water filled end treatment designed and tested to the crashworthy requirements of MASH. The Lo-Ro SLED shall be used to treat the ends of Lo-Ro barrier. The Lo-Ro SLED shall be installed where the ends of Lo-Ro barrier are exposed to vehicle travel.

The Lo-Ro SLED shall be constructed of a plastic module yellow in color with the steel Containment Impact Sled (CIS) pinned to the module.

Each SLED System shall consist of:

- Virgin polyethylene plastic, containing UV stabilizers and antioxidants molded to a triple faced saw tooth profile. The saw tooth ribbed surfaces shall be a flat profile to adhere reflective sheeting if specified.
- A steel galvanized CIS frame shall be pinned directly to the yellow water filled Lo-Ro SLED module.
- The CIS face that is exposed to traffic shall contain a plastic panel contain gore point reflective sheeting on one side and on the opposite side contain directional (Rt/Lt) sheeting to allow the user to change the directional panel during installation.
- The ends of each module shall be constructed with vertically aligned knuckles which interlock with those of adjacent modules and accept a steel connecting pin. The pin is retained after installation by a keeper pin.
- Each module shall contain three internal molded-in cables acting as a cable barrier when impacted. Each cable is connected to a steel bushing which is molded into the knuckle sections and is of appropriate diameter to meet design speeds of TL-2 impacts.
- The approximate dimensions, weight, and volume of each barrier section shall be: 571 mm [22.5 in.] width x 1084 mm [42 11/16 in.] height x 1924 mm [75 3/4 in] length (pin to pin). Empty weight 72.6 kg [160 lb], weight filled 907 kg [2000 lb], water ballast 832 L [220 gal].
- Modules shall be manufactured yellow in color designating it as an end treatment.
- Each section shall be manufactured with fork lift openings to allow for lifting when empty or full.
- Each module shall be manufactured with one 8 in. [203.2 mm] diameter twist lock fill lid and a 2.25 in. [57.15 mm] diameter molded-in Buttress threaded drain hole with a plug

TraFFix Devices Inc.
TraFFix Lo-Ro Water Cable Barrier
General Specifications

III. Performance Criteria

The Lo-Ro SLED shall be tested and passed all crashworthy requirements of MASH for Test Level 2 (TL-2) impact conditions for 1100 kg [2425 lbs] and 2270 kg [5004 lbs] vehicles at impact speeds of 70 km/h [43.5 mph].

The Lo-Ro SLED test results shall demonstrate that a water filled gating non-redirective end treatment shall safely decelerate the 1100C and 2270P MASH impact vehicles and shall not exceed the maximum allowable occupant risk values:

Occupant Impact Velocity (OIV)

Maximum allowable: 12.2 m/s

RideDown Acceleration (RA)

Maximum allowable: 20.49 G's

The Lo-Ro SLED shall be capable of preventing vehicle penetration, vaulting, under riding, and shall bring the impacting vehicle to a controlled stop.



Appendix C:

Lo-Ro Limited

Warranty

160 Ave. La Pata
San Clemente, California 92673
(949) 361-5663
FAX (949) 361-9205
www.traffixdevices.com



Lo-Ro Limited Warranty

TrafFix Devices warrants to the purchaser that the Lo-Ro Barrier and Lo-Ro SLED is free from any defects in materials and workmanship. If this product proves to be defective in material or workmanship during the period of this warranty, TrafFix Devices will repair or replace (at its discretion) the defective product free of charge (except for transportation charges). The period of this warranty is the one-year period beginning from the date the unit is in service or one year from the date of purchase from TrafFix Devices.

To obtain warranty service, the purchaser or distributor must first fill out a warranty authorization form and email to TrafFix Devices to have engineering evaluate and recommend replacement or repair procedures. **TrafFix Devices will then issue a signed warranty work approval** form to authorize the distributor or customer to repair or replace any items, which TrafFix deems to have been defective.

This warranty does not extend to any failure caused by misuse, abuse or material alteration of this product, or any negligence in connection with the installation, service, or use of this product. For the correct installation, service, or use of this product refer to the installation manual.

Warranty Authorization Form

Company Name _____
Address _____
Phone, Fax Number, and E-Mail _____
Name of Customer _____
Date _____
Serial number: _____
Replacement and Repair parts listed below?

List part numbers of replacement or repair items: _____

9. Describe the problem and reason for failure: _____

10. Email this form with any pictures and contact TrafFix Devices engineering department.

Phone: (949) 361-5663 E-mail: info@traffixdevices.com

160 Ave. La Pata
San Clemente, California 92673
(949) 361-5663
FAX (949) 361-9205
www.traffixdevices.com

Appendix D:

Regional Sales Managers, Key Contacts, & Customer Service

160 Ave. La Pata
San Clemente, California 92673
(949) 361-5663
FAX (949) 361-9205
www.traffixdevices.com

Regional Sales Managers

Northeast Territory Office

VA, WV, DL, MD, NJ, NY, PA, CT, MA, RI, NH, VT, ME, D.C.

Mike Herlehy

Rochester, NY

(585) 267-9970 office

(949) 573-9239 fax

mherlehy@traffixdevices.com

Southeast Territory Office

TN, NC, SC, GA, MS, AL, FL

Lary Hudoff

Miami, FL

(770) 778-8281 office

(949) 325-6059 fax

lhudoff@traffixdevices.com

Northwest Territory Office

MT, UT, ID, WA, OR, NV, CO, WY

Cary LeMonds

St. George, UT

(801) 979-7099 office

(949) 573-9290 fax

clemonds@traffixdevices.com

Midwest Territory Office

OH, MI, IN, KY, IL, WI, MN, ND, SD, IA, MO

Dave H. Lindquist

Chicago, IL

(630) 605-1273 office

(949) 573-9240 fax

dlindquist@traffixdevices.com

Western Territory Office

CA, HI, AK, AZ

Lawrence Berg

San Diego, CA

(949) 350-7048 office

(949) 573-9267 fax

lberg@traffixdevices.com

Southwest Territory Office

TX, OK, KS, NE, NM, AR, LA

John Gense

Dallas, TX

(214) 704-1476 office

(949) 573-9291 fax

jgense@traffixdevices.com

VP International Sales & Marketing

Brent Kulp

San Clemente, CA

(949) 361-5663 office

(949) 573-9264 fax

bkulp@traffixdevices.com

To Place Orders

Email: orders@traffixdevices.com

Office: (949) 361-5663

Fax: (949) 573-9250

Key Contacts

Chris Giordano	Director of Business Development	cgiordano@traffixdevices.com	(216) 233-3273
Geoff Maus	V.P. Engineering	gmaus@traffixdevices.com	(949) 361-5663
Felipe Almanza	V.P. New Product Development	falmanza@traffixdevices.com	(949) 361-5663
Brent Kulp	V.P. Int'l Sales & Marketing	bkulp@traffixdevices.com	(949) 573-9214
Scott Ryan	V.P. North American Sales	sryan@traffixdevices.com	(949) 573-9216
Jim Marshall	V.P. Marketing	jmarshall@traffixdevices.com	(949) 361-5663

Customer Support Services

Jim Abercrombie	Manager, Customer Support	jabercrombie@traffixdevices.com	(949) 573-9217
Diane Womack	Customer Service Rep.	dwomack@traffixdevices.com	(949) 573-9237
Mark Wages	Customer Service Rep.	mwages@traffixdevices.com	(949) 573-9240
Terry Glogow	Customer Service Rep.	tglogow@traffixdevices.com	(949) 573-9246

TraFFix Devices, Inc. Headquarters

160 Ave. La Pata, San Clemente, CA 92679 - (949) 361-5663 - Fax (949) 361-9250

www.traffixdevices.com

Notes

Notes



160 Ave. La Pata San Clemente, California 92673
(949) 361-5663 FAX (949) 361-9205
www.traffixdevices.com

Distributed By: