

SPARE PARTS LIST

PART NUMBER	ITEM DESCRIPTION	QTY ASSEM.	UNIT LIST PRICE (\$)
1	80301 Base Plate	1	42.90
1A	80301B Hex. Bolt	2	0.55
2	24302 Hex. Lock Nut	6	0.25
3	24303 Spacer Washer	8	2.55
4	24304 Hex. Bolt	4	0.55
5	24305 Tie Bracket	2	3.75
6	24306 Channel Bracket	4	1.45
7	24307 Step Lever	4	1.55
8	24308 Extension Spring	4	0.45
9	24309 Cover Plate	4	0.30
10	24310 Round Head Screw	8	0.15
11	24311 Leg	4	12.00
12	24319 Lock Washer	2	0.15
13	24320 Outer Mast	1	13.75
14	24322 Inserted Plate Spring	1	1.80
15	24323 Inner Mast	1	12.90
16	24324 Flag Holder Assy	1	13.90
FLAG HOLDER ASSEMBLY INCLUDES THE FOLLOWING:			
16A	24324A Flag Holder	1	8.40
16B	24324B Clamp	1	3.30
16C	24324C Carriage Bolt	2	0.35
16D	24324D Compression Spring	2	0.45
16E	24324E 5/16 Butterfly Nut	2	0.35
17	24325-A Round Head Screw	2	0.15
	24325-B Lock Nut	2	0.15
18	24326 Black Cap	4	0.70
20	24321 Rigid Sign Bracket	1	19.80
21	24000-BRU Roll-Up Sign Bracket	1	23.00
22	24350 350 Compliant; Rigid Sign Bracket	1	34.00

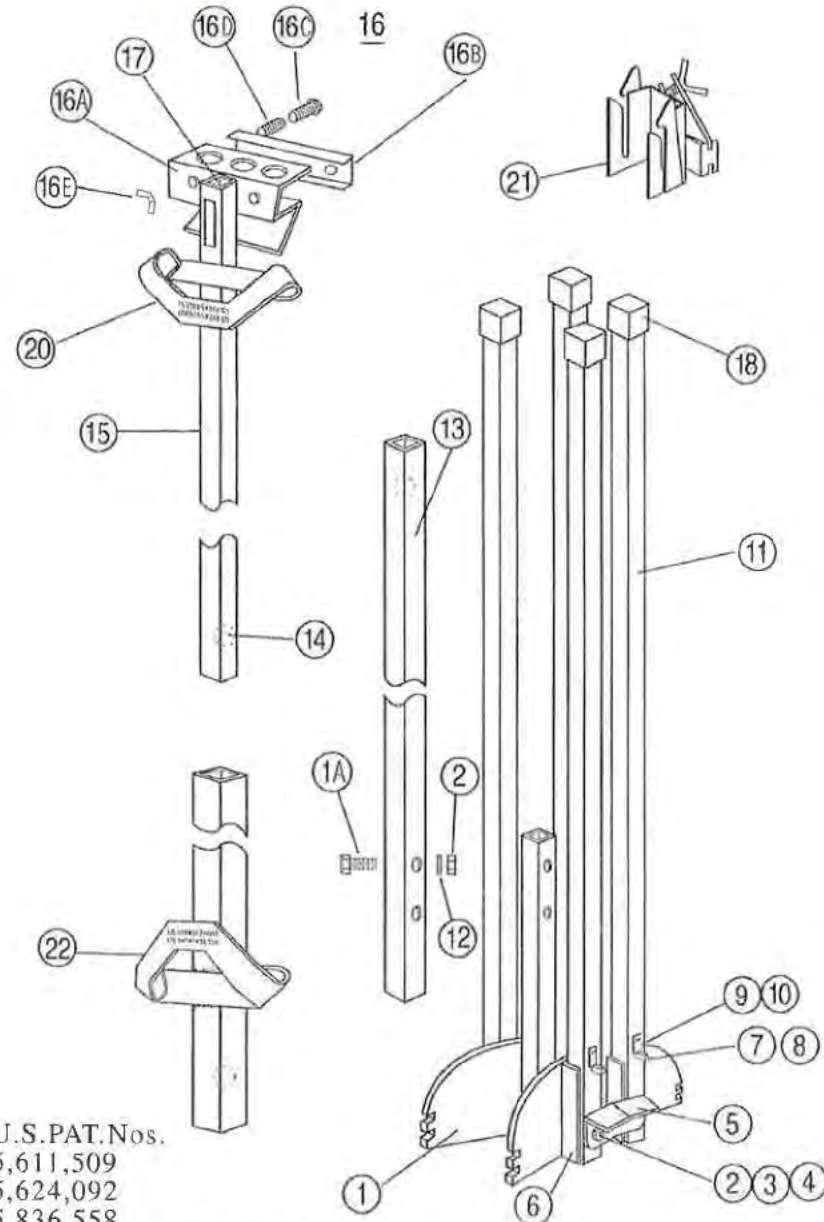

U.S. PAT. Nos.
5,611,509
5,624,092
5,836,558
OTHER PATENTS PENDING