



U.S. Department
of Transportation
Federal Highway
Administration

July 31, 2000

400 Seventh St., S.W.
Washington, D.C. 20590
Refer to: HSA-I

Mr. Dave Gertz
TrafFix Devices, Inc.
Director of Engineering
220 Calle Pintoresco
San Clemente, California 92672

Dear Mr. Gertz:

Thank you for your letter of April 20,2000, requesting Federal Highway Administration (FHWA) acceptance of your company's barricades and portable sign stands as crashworthy traffic control devices for use in work zones on the National Highway System (NHS). Accompanying your letter were two reports from Karco Engineering dated January 27 and March 8,2000, a detailed description and drawing of each device, and videos of the crash tests. You requested that we find the listed devices acceptable for use on the NHS under the provisions of National Cooperative Highway Research Program (NCHRP) Report 350 "Recommended Procedures for the Safety Performance Evaluation of Highway Features." You provided additional information on July 15, and Karco sent additional photographs and information on July 19, both in response to our request.

Introduction

The FHWA guidance on crash testing of work zone traffic control devices is contained in two memoranda. The first, dated July 25, 1997, titled "Information: Identifying Acceptable Highway Safety Features," established four categories of work zone devices: Category I devices were those lightweight devices which could be self-certified by the vendor, Category II devices were other lightweight devices which needed individual crash testing, Category III devices were barriers and other fixed or massive devices also needing crash testing, and Category IV devices were trailer mounted lighted signs, arrow panels, etc. The second guidance memorandum was issued on August 28, 1998, and is titled "INFORMATION: Crash Tested Work Zone Traffic Control Devices." This later memorandum lists devices that are acceptable under Categories I, II, and III.

A brief description of the devices for which you are requesting acceptance follows:

1. Blow molded plastic folding Type 1 barricade with two sand-filled panels, Emnco-Lite Model No. 100 warning light and light bolt heavy duty projector.
 - A. Legs and panels are blow molded of high density polyethylene.
 - B. Top panels are 203 mm x 610 mm (8x24 inches)
 - C. Height to top of panel is 933 mm (36.75 inches)
 - D. Mass is 5.5 kg (12 pounds) maximum without sand.
 - E. Mass of sand ballast used in tests was 6.4 kg (14 pounds)

2. Blow molded plastic folding barricade. Emuco-Lite Model No.100 wamine light and light bolt heavy-duty protector.
 - A. Legs and panels are blow molded of high density polyethelene.
 - B. Top panels arc 203 mm x 610 mm (8x24 inches)
 - C. Height to top of panel is 933 mm (36.75 inches)
 - D. Mass is 5.5 kg maximum.

3. Traffix Type I or Type II barricade with folding steel (14 gage) lees. Emuco-Lite Model No. 100 warning light and light bolt heaw duty protector
 - A. Panels are inject molded high density polyethylene.
 - B. Legs are 14 ga hot rolled steel angle, 30 mm x 32 mm (1.2 x 1.3 inches).
 - C. Top panels are 203 mm x 610 mm (8x24 inches)
 - D. Height to top of panel is 933 mm (36.75 inches)
 - E. Mass is 6.6 kg. (14.5 pounds)

4. Zephyr portable sign stand with 1220 x 1220 mm (48 x 48-inch) rollup sign. Mounting height 305 mm (12-inches) above around.
 - A. Base is 100 percent recycled rubber over molded steel plate
 - B. Total weight of stand is 17.2 kg (38 pounds)
 - C. Base dimensions are 710 mm long x 430 mm wide x 92 mm high (28 x 17 5/8 x 3 5/8 -inches)
 - D. Fold down mast is hot rolled 14 gage (44 mm, 1 3/4 inches) square steel tubing 360 mm (14 inches) tall

5. Aluminum Buster sign stand with 1220 x 1220 mm (48 x 48-inch) rigid plastic sign. Mounting height 305 mm.
 - A. Footprint of stand with legs open to position one 990 mm x 2000 mm (39x79 inches)
 - B. Footprint of stand with legs open to position two 910 mm x 1850 mm (36x73 inches)
 - C. Lower mast is aluminum extrusion 38 mm (1 1/2 inches) square tubing with 2.5 mm (0.10 inch) wall thickness
 - D. Upper mast is 32 mm (1 1/4 inches) square tubing of PVC plastic. Wall thickness is 6.4 mm (1/4 inches).
 - E. Rigid plastic sign is corrugated polyethylene, 10 cm (0.4 inch) thick, wall 0.9 mm (0.034 inch) thick. Mass is 3.6 kg (8 pounds.)
 - F. Overall mass is 18 kg. (40 pounds.)

6. Little Buster dual spring folding sign stand with 1220 x 1220 mm (48 x 48-inch) rigid plastic sign Mounting height 305 mm
 - A. Footprint of stand with legs open to position one 990 mm x 2000 mm (39x79 inches)
 - B. Footprint of stand with legs open to position two 910 mm x 1850 mm (36x73 inches)
 - C. Lower mast is hot rolled 16 ga steel tubing, 30mm (1.2 inch) square.

- D. Rigid plastic sign is corrugated polyethylene, 10 cm (0.4 inch) thick, wall 0.9 mm (0.034 inch) thick. Mass is 3.6 kg (8 pounds.)
- E. Overall mass is 18 kg. (40 pounds.)
7. Little Buster sign stand with 1220 x 1220 mm (48 x 48-inch) rollup sign. Mounting height 305 mm
- A. Footprint of stand with legs open to position one 990 mm x 2000 mm (39x79 inches)
- B. Footprint of stand with legs open to position two 910 mm x 1850 mm (36x73 inches)
- C. Lower mast is hot rolled 16 ga steel tubing, 30mm (1.2 inch) square.
- D. Overall mass is 18 kg. (40 pounds.)
8. Metal Leg barricade with folding steel 12 ea leas. with Emnco-Lite Model No. 100 and light bolt heaw dutv protector
- A. Panels are inject molded high density polyethylene
- B. Legs are 12 ga hot rolled steel angle 30 mm x 33 mm (1.2 x 1.3 inches)
- C. Top panels are 203 mm x 610 mm (8x24 inches)
- D. Height to top of panel is 933 mm (36.75 inches)
- E. Mass is 7.7 kg. (17 pounds.)
9. TraFFix-Standard 1220 x 1220 mm (48 x 48-inch) rolluo sign. Mounting height 305 mm
- A. Footprint of stand with legs open to position one 990 mm x 2000 mm (39x79 inches)
- B. Footprint of stand with legs open to position two 910 mm x 1850 mm (36x73 inches)
- C. Lower mast is hot rolled 12 gage 44 mm (1 3/4 inches) square steel tubing 360 mm (14 inches) tall
- D. Overall mass is 18 kg. (40 pounds.)
10. Econo Buster sign stand with 1220 x 1220 mm (48 x 48-inch) rield plastic sign. Mounting height 305 mm
- A. Footprint of stand with legs open to position one 990 mm x 2000 mm (39x79 inches)
- B. Footprint of stand with legs open to position two 910 mm x 1850 mm (36x73 inches)
- C. Lower mast is hot rolled 16 ga steel tubing, 30mm (1.2 inch) square
- D. Rigid plastic sign is corrugated polyethylene, 10 cm (0.4 inch) thick, wall 0.9 mm (0.034 inch) thick. Mass is 3.6 kg (8 pounds.)
- E. Overall mass is 18 kg. (40 pounds.)
11. Little Buster sign stand with 1525 mm (five foot) hieh roll-un sign
- A. Footprint of stand with legs open to position one 990 mm x 2000 mm (39x79 inches)

- B. Footprint of stand with legs open to position two 910 mm x 1850 mm (36x73 inches)
 - C. Overall mass is 18 kg. (40 pounds.)
 - D. Leg material 25.4 mm (1 inch) hot rolled steel square tubing with 1.52 mm (0.060 inch) wall
 - E. Outer mast material 30.5 mm (1.2.inch) steel square tubing with 1.52 mm wall
 - F. Inner mast material 25.4 mm (1 inch) hot rolled steel square tubing with 1.52 mm wall
 - G. Vinyl sign, 2.7 kg. (6 pounds)
12. Little Buster sign stand with 1220 x 1220 mm (48 x 48-inch) rigid Aluolic ® sign. Mounting height 380 mm (15 inches)
- A. Footprint of stand with legs open to position one 990 mm x 2000 mm (39x79 inches)
 - B. Footprint of stand with legs open to position two 910 mm x 1850 mm (36x73 inches)
 - C. Overall mass is 18 kg. (40 pounds.)
 - D. Leg material 25.4 mm (1 inch) hot rolled steel square tubing with 1.52 mm wall
 - E. Outer mast material 30.5 mm (1.2 inch) hot rolled steel square tubing with 1.52 mm wall
 - F. Inner mast material 25.4 mm (1 inch) hot rolled steel square tubing with 1.52 mm wall
 - G. Rigid Alpolic ® sign mass 4.5 kg (10 pounds). Aluminum skin 0.25 mm (0.010 inches) thick on either side of plastic core, overall thickness 2.5 mm (0.10 inch.)
13. Econo Buster sign standwith 1220 x 1220 mm (48 x 48-inch) rield Aluolic ® sign Mounting height 380 mm (15-inches)
- A. Leg material 25.4 mm (1 inch) hot rolled steel square tubing with 1.52 mm wall
 - B. Outer mast material 30.5 mm (1.2 inch) hot rolled steel square tubing with 1.52 mm wall
 - C. Inner mast material 25.4 mm (1 inch) hot rolled steel square tubing with 1.52 mm wall
 - D. Rigid Alpolic ® sign, mass 4.5 kg (10 pounds). Aluminum skin 0.25 mm (0.010 inches) on either side of plastic core, overall thickness 2.5 mm (0.10 inch)
14. Big Buster with Rigid Alnolic ® mounting heieht 1525 mm (60 inches) off the ground
- A. Footprint of stand with legs open to position one 990 mm x 2000 mm (39x79 inches)
 - B. Footprint of stand with legs open to position two 1450 mm x 3175 mm (57x125 inches)
 - C. Overall mass is 18 kg. (40 pounds.)
 - D. Leg material 3 1.75 mm (1.25 inch) square extruded aluminum tubing with 2.5 mm (0.10 inch) wall

E. Outer mast material 38 mm (1.5 inch) square extruded aluminum tubing with 2.5 mm wall

F. Upper mast is 32 mm (1 1/4 inches) square tubing of PVC plastic. Wall thickness is 6.4 mm (1/4 inches).

G. Rigid Alpolic ® sign mass 4.5 kg (10 pounds). Aluminum skin 0.25 mm (0.010 inches)

Testing

Full-scale automobile testing was conducted on your company's devices. Two stand-alone examples of the device were tested in tandem, one head-on and the next placed six meters downstream turned at 90 degrees, as called for in our guidance memoranda. The complete devices as tested are shown in Enclosure 1.

The crash tests are summarized in the table below:

Test #	W i n d s h i e l d D a m a g e			A s s e s s m e n t
1	103.0	102.0	0.3	No contact with test article
2	101.7	100.7	0.3	No contact with test article
3	101.8	101.5	0.1	No contact with test article
4	97.6	96.9	0.2	Significant localized cracking, no intrusion
5	97.3	96.9	0.4	Significant overall cracking, No intrusion
6	101.5	100.2	0.4	No damage
7	100.3	99.7	0.2	Significant localized damage, no intrusion
8	98.7	97.8	0.3	Contact, but no damage
9	100.6	98.9	0.5	Significant localized damage, no intrusion
10	101.2	100.1	0.3	Significant localized damage, no intrusion
"11"***	102.0	99.9	0.6	Localized damage, no intrusion
"12"	100.2	99.0	0.3	Overall damage, no intrusion
"13"	101.0	98.4	0.7	Significant overall damage, no intrusion
"14"	100.3	97.6	0.8	No damage

* Delta V: Velocity change of the test vehicle after striking the first object, oriented head-on.

** Items listed as numbers 11 through 14 were the subjects of tests numbers 1 through 4 in the March 8, 2000, test report.

Findings

Damage to the vehicles was limited to dents to the bumpers, hoods, and to the windshields as noted above. Although some impacts caused significant cracking at the point of impact, none appeared to be severe enough to cause penetration nor extensive enough to completely block the view of the driver. No windshield impacts caused a hole through the glass.

The results of this testing met the FHWA requirements and, therefore, the devices listed below and illustrated in Enclosure 1 are acceptable for use as Test Level 3 devices on the NHS under the range of conditions tested, when proposed by a State.

Device Name	Test Numbers	Acceptable with...
Plastic Folding Barricade	1,2	Empco Lite #100 warning light
Metal Leg Folding Barricade	3,8	Empco Lite #100 warning light
Zephyr Portable Sign Stand	4	1220x1220mm Rollup sign
Aluminum Buster sign stand	5	1220 x 1220 mm rigid plastic sign
Little Buster sign stand (305 mm mounting height)	6	1220 x 1220 mm rigid plastic sign
	7	1220 x 1220 mm rollup sign
Little Buster sign stand (1525 mm mounting height)	11*	1220 x 1220 mm rollup sign
	12*	1220 x 1220 mm Alpolite sign
Traffix Stand (305 mm mt. height)	9	1220 x 1220 mm rollup sign
Econo Buster folding leg sign stand (305 mm mounting height)	10	1220 x 1220 mm rigid plastic sign
Econo Buster folding leg sign stand (380 mm mounting height)	13*	1220 x 1220 mm Alpolite sign
Big Buster (1525 mm mt. height)	14*	1220 x 1220 mm Alpolite sign

* Test Numbers 11, 12, 13, and 14 correspond to tests 1, 2, 3, and 4 in the March 2000 test report.

Please note the following standard provisions which apply to FHWA letters of acceptance:

- Our acceptance is limited to the crashworthiness characteristics of the devices and does not cover their structural features, nor conformity with the Manual on Uniform Traffic Control Devices.
- Any changes that may adversely influence the crashworthiness of the device will require a new acceptance letter.
- Should the FHWA discover that the qualification testing was flawed, that in-service performance reveals unacceptable safety problems, or that the device being marketed is significantly different from the version that was crash tested, it reserves the right to modify or revoke its acceptance.
- You will be expected to supply potential users with sufficient information on design and installation requirements to ensure proper performance.
- You will be expected to certify to potential users that the hardware furnished has essentially the same chemistry, mechanical properties, and geometry as that submitted for acceptance, and that they will meet the crashworthiness requirements of FHWA and NCHRP Report 350.
- To prevent misunderstanding by others, this letter of acceptance , designated as number WZ-46, shall not be reproduced except in full.
- Many Traffix work zone devices are patented products and considered “proprietary.” The use of proprietary work zone traffic control devices in Federal-aid projects is generally of a temporary nature. They are selected by the contractor for use as needed and removed upon completion of the project. Under such conditions they can be presumed to meet requirement “a” given below for the use of proprietary products on Federal-aid projects. On the other hand, if proprietary devices are specified for use on Federal-aid projects, except exempt, non-NHS projects, they: (a) must be supplied through competitive bidding with equally suitable unpatented items; (b) the highway agency must certify that they are essential for synchronization with existing highway facilities or that no equally suitable alternative exists or; (c) they must be used for research or for a distinctive type of construction on relatively short sections of road for experimental purposes. Our regulations concerning proprietary products are contained in Title 23, Code of Federal Regulations, Section 635.411, a copy of which is enclosed.

Sincerely yours,

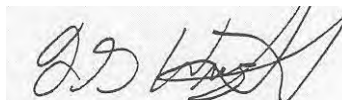

Frederick G. Wright, Jr.
Program Manager, Safety

2 Enclosures

FHWA:HSA-I N. Artimovich:lb:x61331:7/27/00
cc: Chron 34(07) - Reader 3407
HSA-I (N Artimovich)

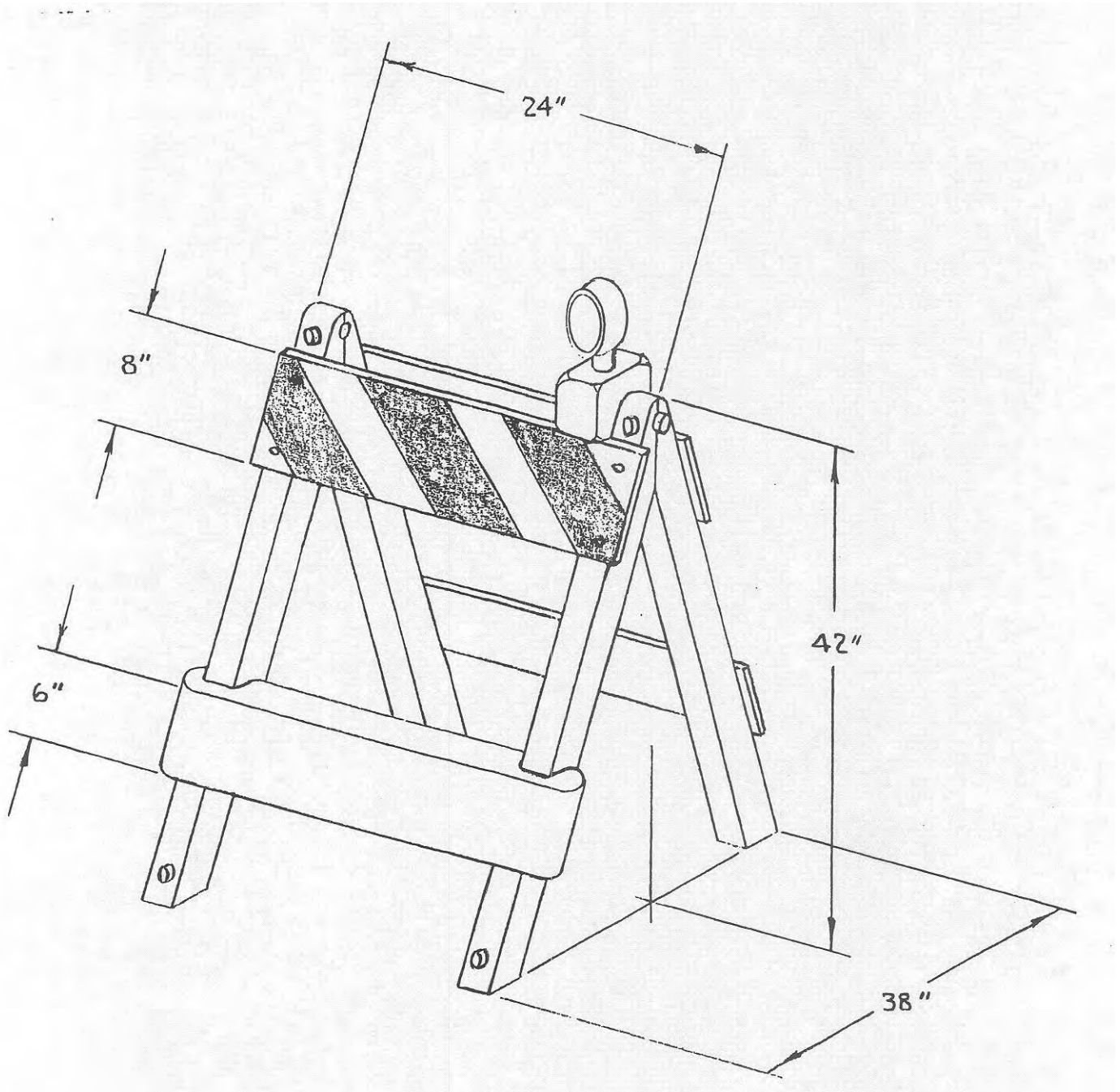

PLASTIC FOLDING BARRICADE

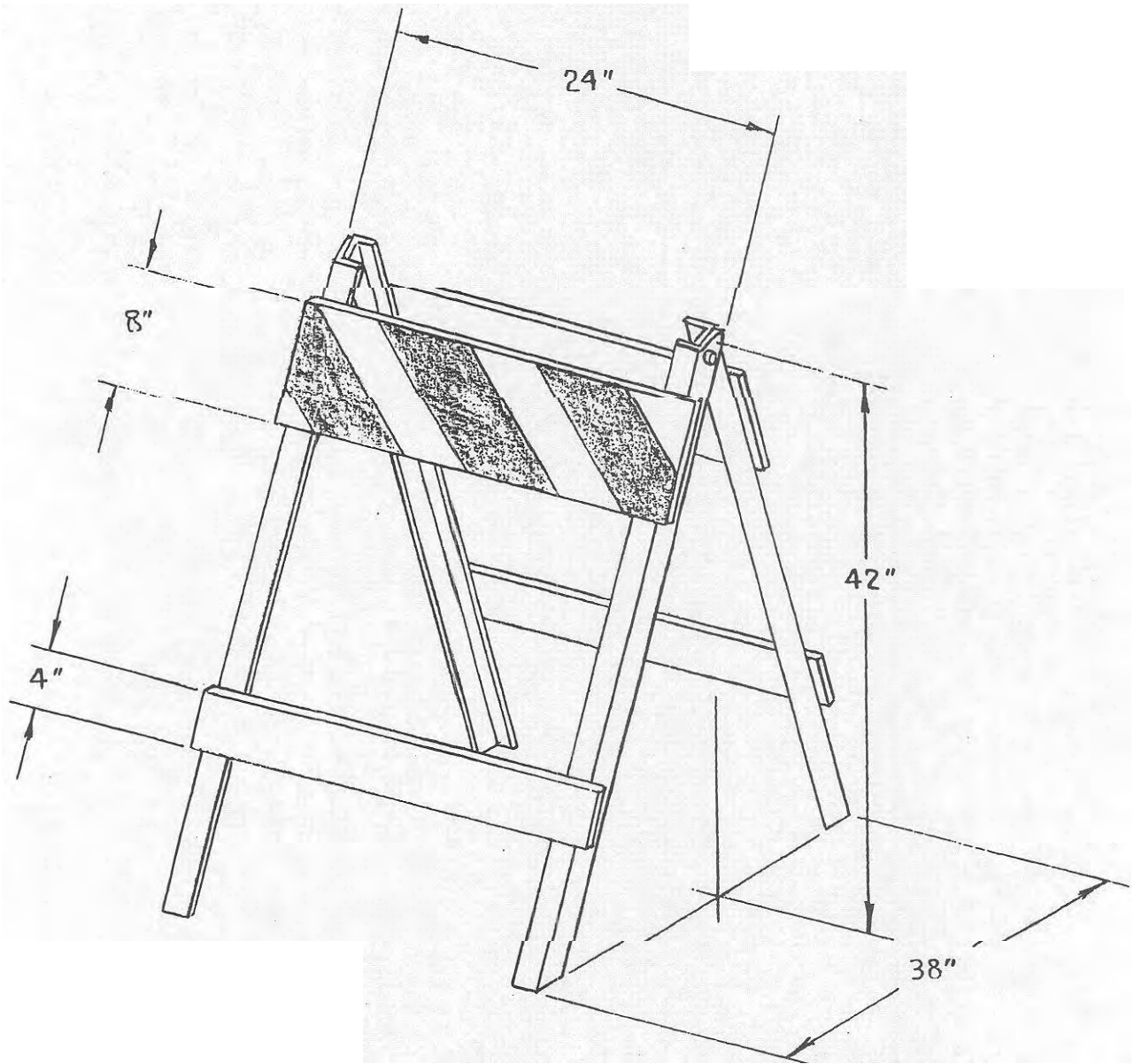

METAL LEG FOLDING BARRICADE

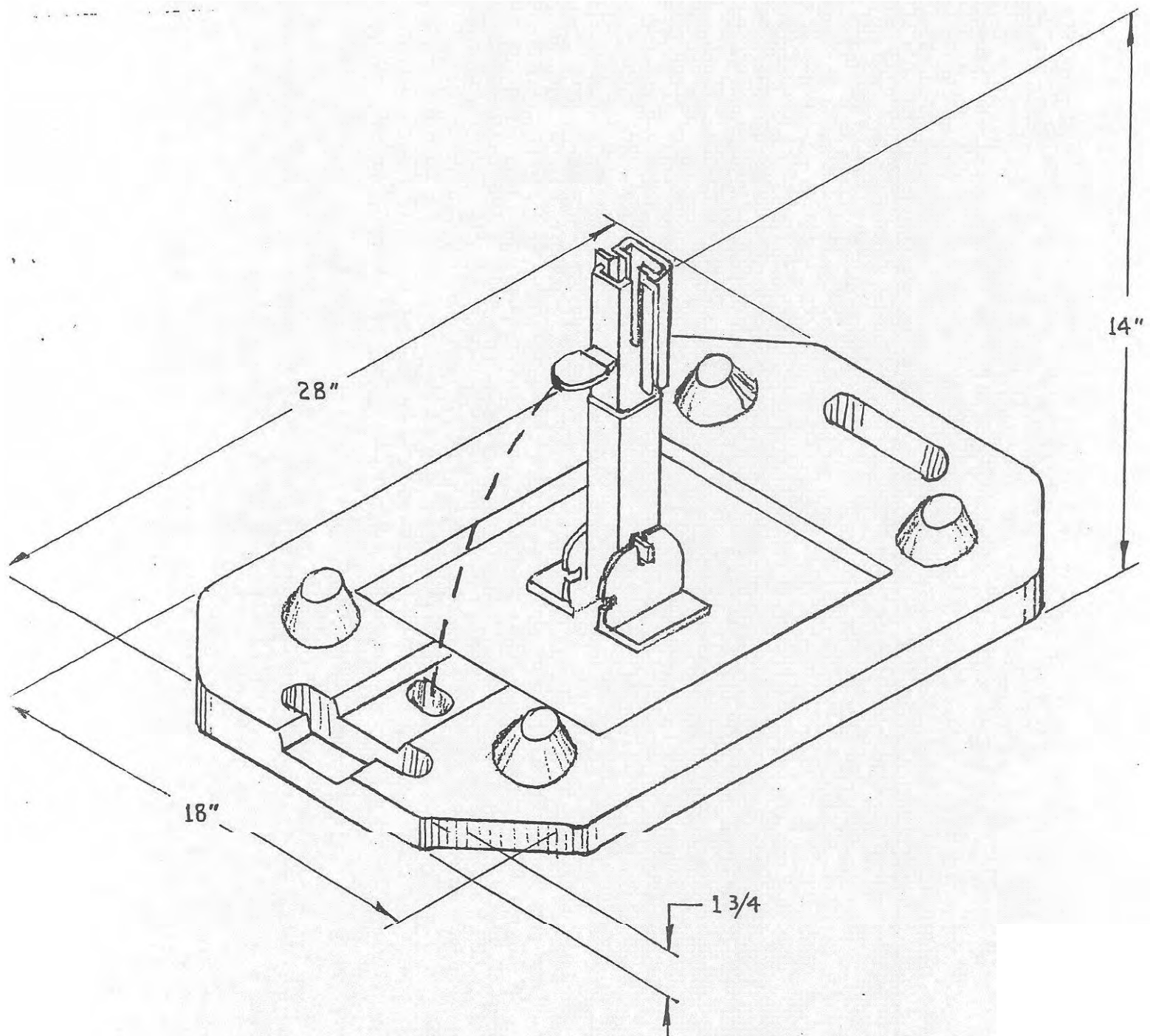

ZEPHYR PORTABLE SIGN STAND

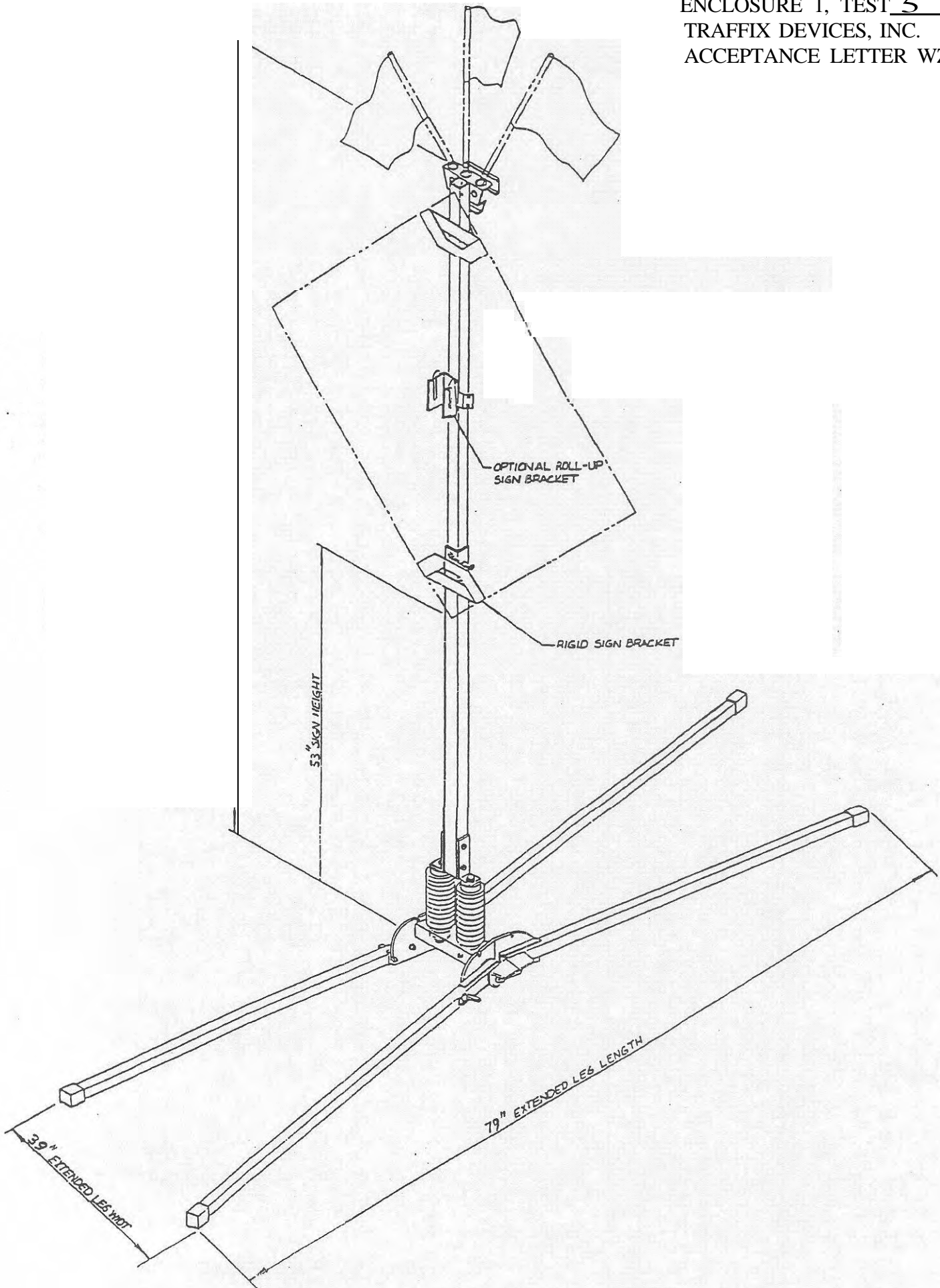

TRAFFIX ALUMINUM BUSTER DUAL SPRING FOLDING LEG SIGN STAND

7.11.12

TRAFFIX DEVICES, INC.
ENCLOSURE 1, TEST 6 Z-46

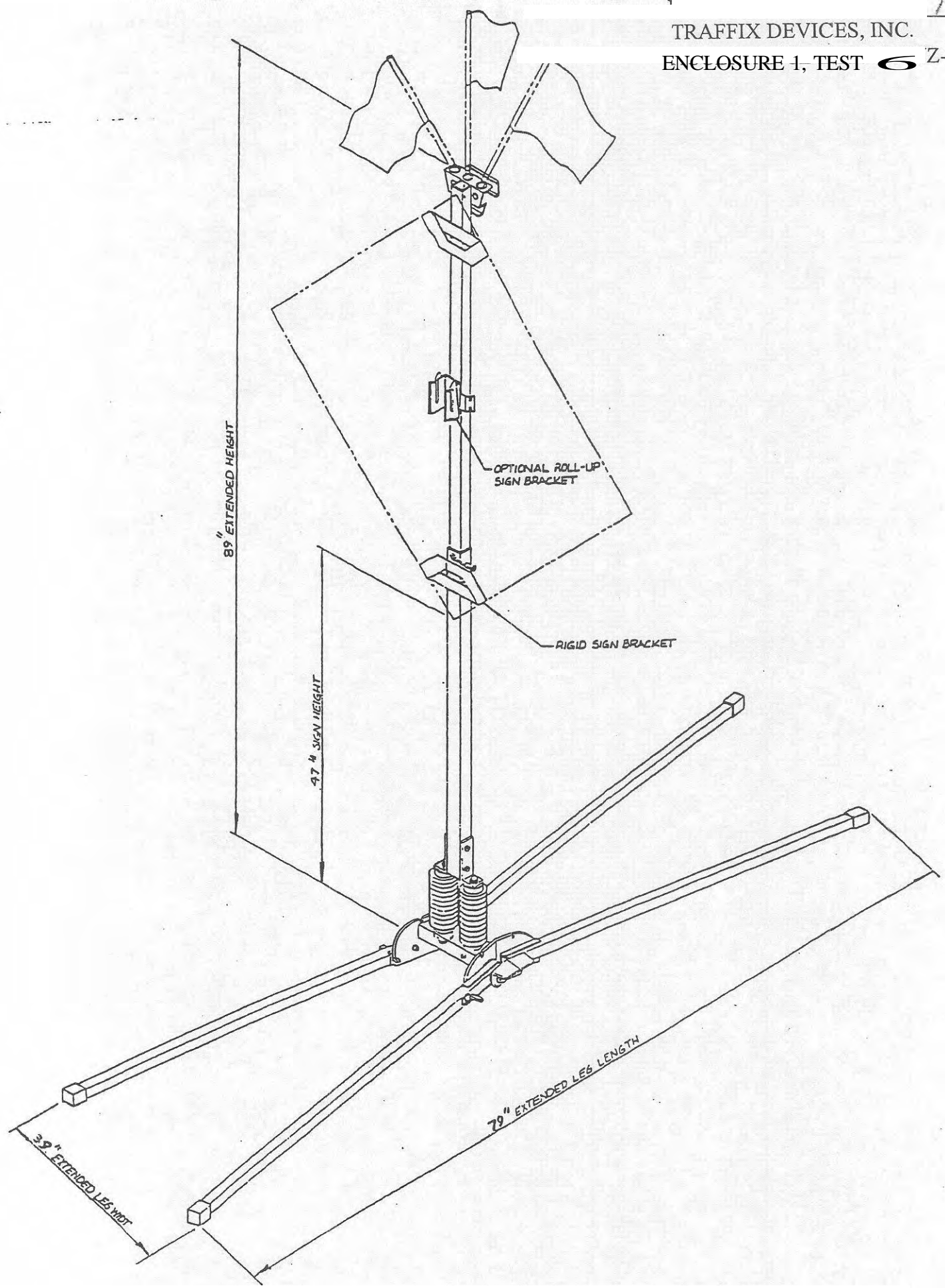

TRAFFIX X LITTLE BUSTER

DUAL SPRING FOLDING LEG SIGN STAND

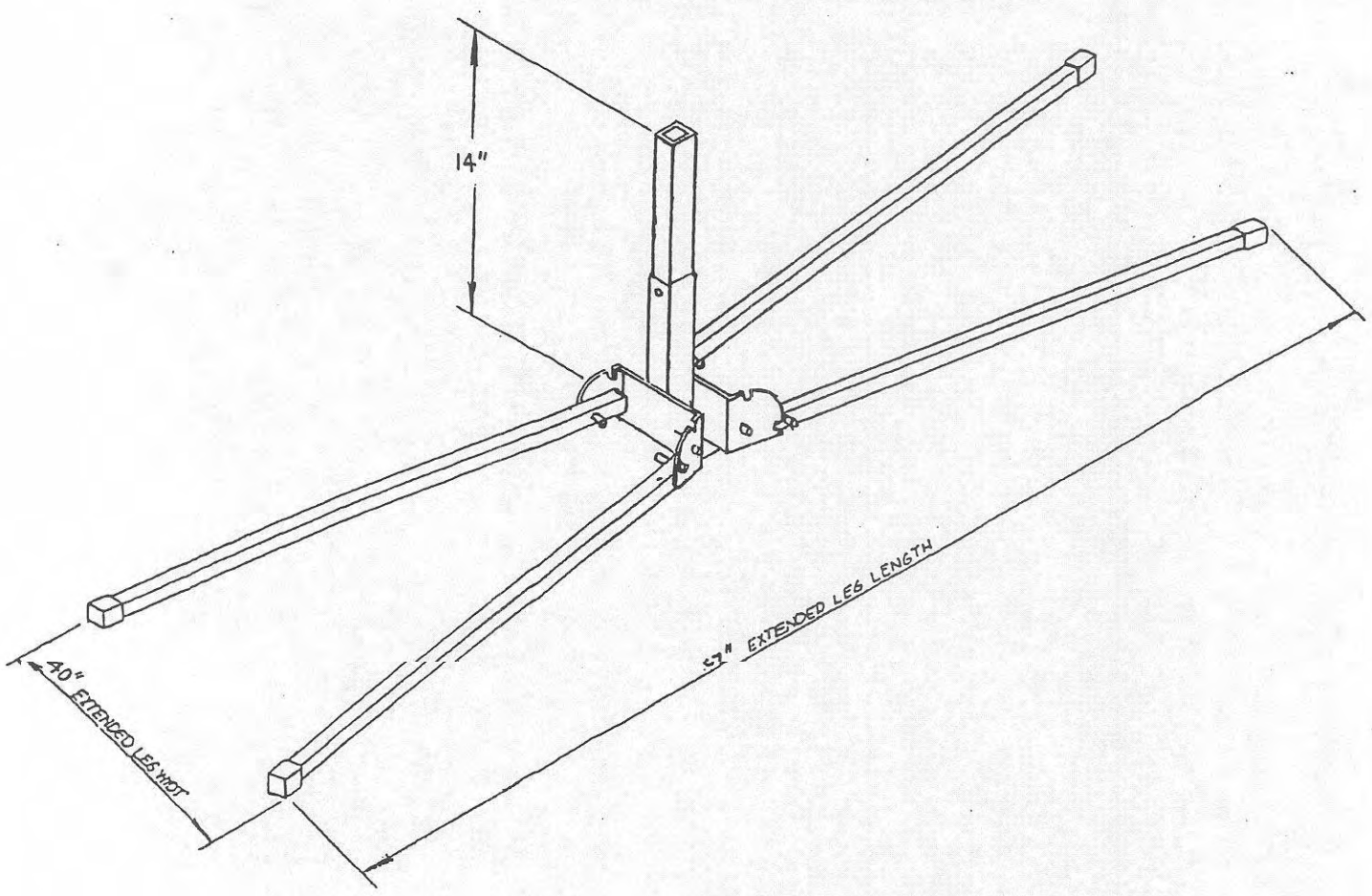

TRAFFIX STAND, FOLDING LEG SIGN STAND

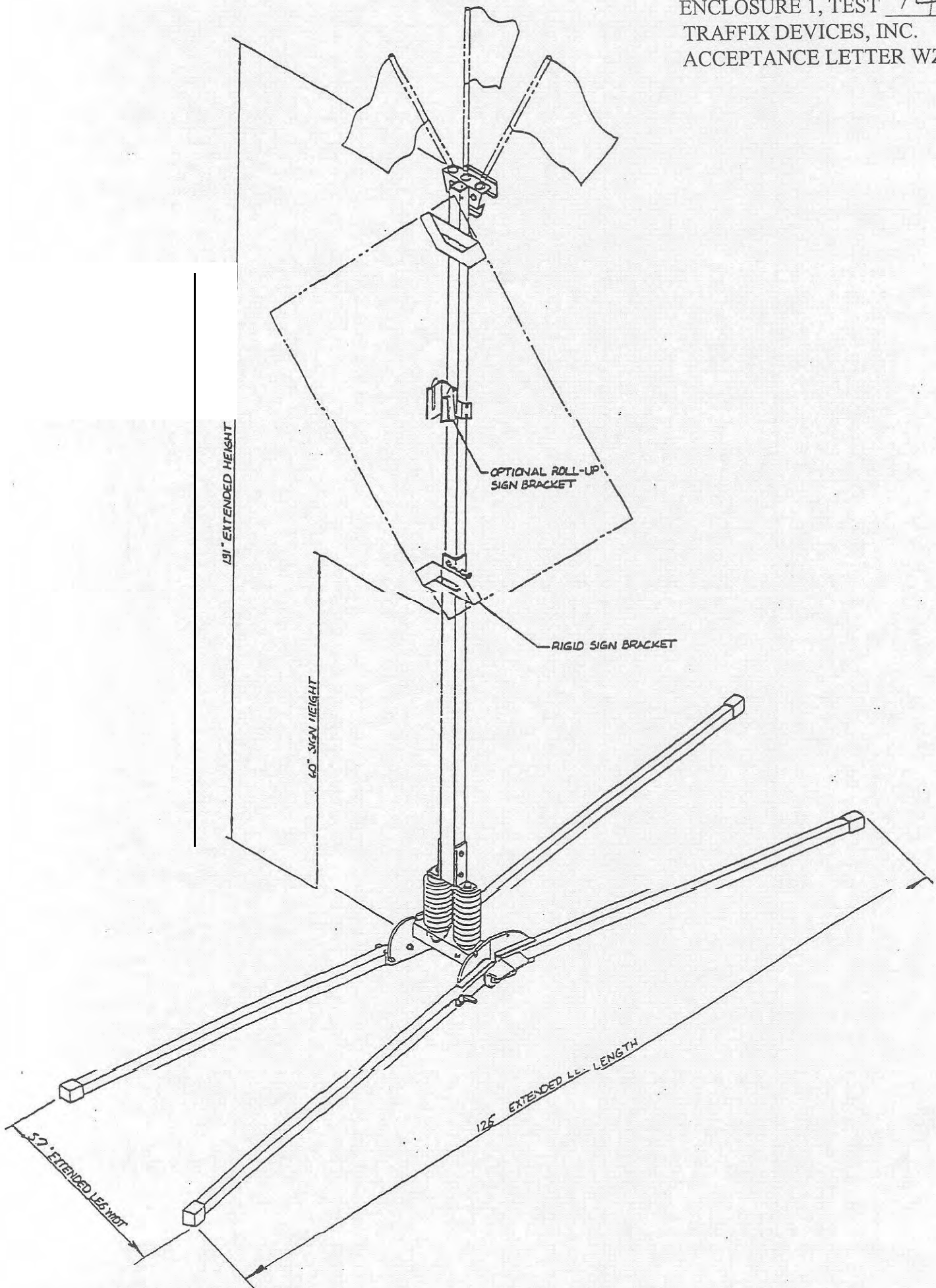

TRAFFIX BIG BUSTER DUAL SPRING FOLDING LEG SIGN STAND